

QSP

QUALITY STAINLESS PRODUCTS

MSC-1000

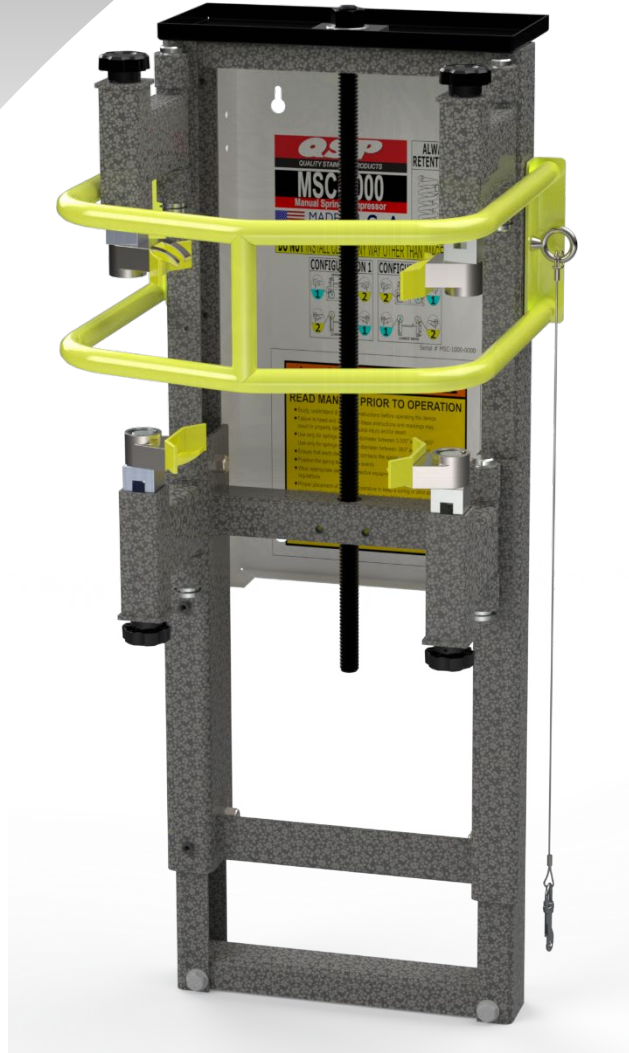

OPERATION & INSTRUCTION MANUAL

This product complies to the ASME standard for Portable Automotive Service Equipment

INSTALLATION INSTRUCTIONS

1. Position the strut compressor in an adequately sized & well-lit area. Refer to image for clearances.
2. Level the unit & anchor to the wall per local codes by following these steps:
 - a. Install 1/4" fasteners according to the image below. Bottom fasteners should be between 23 & 34 inches from the floor.
 - b. After installing fasteners, lift the strut compressor (125lbs) into place and tighten fasteners.
3. Install spring hooks onto the arms of the strut compressor.
4. Store any unused hooks or accessories in the tool tray on top of the unit.

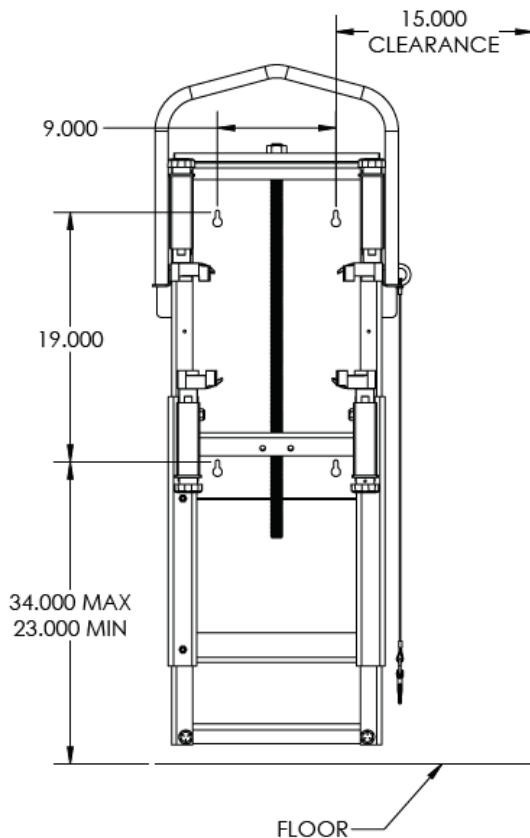

ACCEPTABLE FASTENER TYPES:

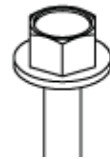

HEX WITH INTEGRATED WASHER

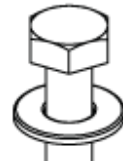

HEX WITH SEPARATE WASHER (MAX Ø 5/8")

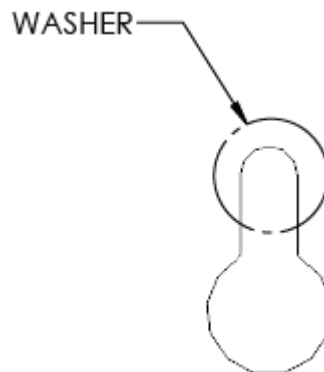

INSTALL FASTENERS THROUGH LARGE OPENING OF SLOTS, AND SLIDE UNIT DOWN SO THAT THE WASHER IS IN POSITION AS SHOWN TO THE LEFT.

It is recommended that you install two fasteners (top preferred), lift the unit into place, then install the lower fasteners.



!! CAUTION !!

DO NOT hang unit on drywall without backing. The use of toggle bolts & drywall anchors are not permitted. Ignoring this advice may cause personal injury and even death.





!! CAUTION !!

Before using this device, safety cage must be lowered!



SAFETY INSTRUCTIONS

- ★ Ensure that MSC-1000 is leveled and secured to the wall.
- ★ Be watchful of pinch points on MSC-1000 & strut assembly; keep extremities out of these areas to avoid injury.
- ★ Prior to starting the compression of any spring, it is imperative to make sure the spring is securely placed between the opposing hooks.
- ★ If a spring begins to deflect or “bow” while under compression, **STOP**, relieve the pressure & reset the clamps closer together.
- ★ Do not place fingers or hands in, on, around, or near moving components while strut compressor is moving.
- ★ Lower safety cage prior to compressing spring.
- ★ Never allow untrained or unauthorized personnel to operate strut compressor.
- ★ Fully train all employees on the proper use and care of your strut compressor.
- ★ One single finger hook and one double finger hook should be used at the top of the unit and also at the bottom.

MAINTENANCE INSTRUCTIONS

To avoid personal injury and damage to strut compressor, permit only qualified personnel to perform maintenance on strut compressor(s). If you are not completely familiar with general automotive equipment maintenance procedures, stop and contact manufacturer for instructions.

DAILY:

- ★ Inspect & repair or replace all loose bolts & damaged or broken components.
- ★ Inspect strut compressor clamp hooks for excessive wear or damage & replace as needed.
- ★ Inspect retention arms, retention cable, knobs, foot pedals, and safety cage for damage and wear, replace as needed.

MONTHLY:

- ★ Inspect support tray & spring retention arm assemblies for damage, wear & tear, and dirt and debris in mechanism. Clean, lubricate, repair & replace components as needed.
- ★ Clean strut compressor & inspect for rust.

EVERY 2 YEARS:

- ★ Check all labels on strut compressor for legibility & make sure no labels are missing. Replace as needed.

EVERY 5 YEARS:

- ★ Replace all claws.

OPERATING INSTRUCTIONS

Before operating your strut compressor, it is necessary to fully read and understand this instruction packet, & the safety instructions. It is also recommended to dry run the strut compressor before compressing a spring to become familiar with its operation and to help equalize air pressure in the system.

While avoiding any pinch points, follow instructions below to compress a spring:

1. Lift safety cage & insert strut assembly into the device. Put the low coil of the spring onto the lower left clamp hook.
2. Adjust lower right arm according to the diameter of the spring & turn the adjustment knob until the hook has engaged the coil and the strut assembly is straight up & down.
3. Adjust the upper hooks so that they capture the spring coils at the highest point. This allows for maximum compression.
4. Rotate handle of support plate counterclockwise ensuring that it can move freely. Lift the support plate and rotate it directly beneath the strut assembly and rotate handle clockwise to lock support plate in place.
5. Lower safety cage.
6. **BENEATH** the safety cage, route the retention cable through two coils on the right side of the spring, then down through the center and out between two lower coils on the right side of the spring. The retention cable **MUST** go around a minimum of one coil of the spring. Illustration below is exaggerated for clarity.
7. **REMOVE HANDS** from working area inside the safety cage.
8. Drive 1-7/16" actuating nut on top of unit to compress spring enough to free strut/shock.
9. While standing beside the unit, remove any fasteners from the strut/shock in the assembly. This will allow the strut/shock to rest on the support plate.
10. While supporting the strut/shock, unlock the support plate and move it to the side.
11. Remove old strut/shock and replace with new unit & replace fasteners.
12. Loosen actuating nut to decompress spring and verify that all of the strut assembly components are in the correct orientation and position.
13. Lift the safety cage, disengage spring hooks, and remove strut assembly.

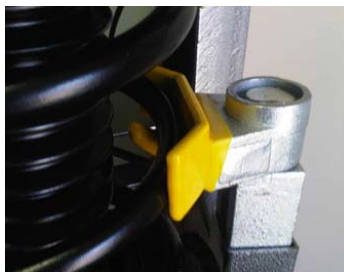
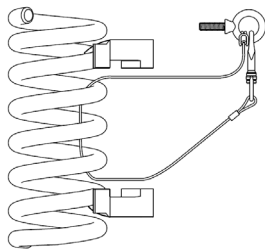

Correct hook engagement on coil.



Incorrect engagement.



!! WARNING !!

DO NOT disable or override the built in safety measures. Serious injury, property damage, or death may result.



!! CAUTION !!

DO NOT position any body part directly above or below spring assembly to be compressed!





!! WARNING !!

INCORRECT claw positioning may result in equipment breakage, property damage, injury and / or death.

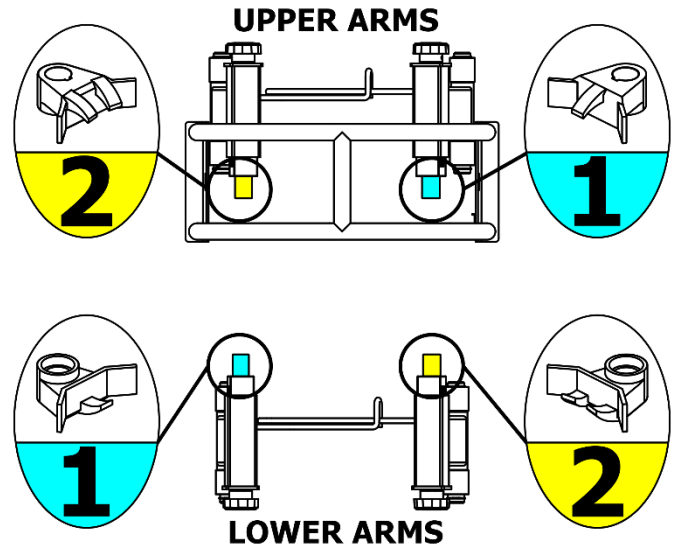
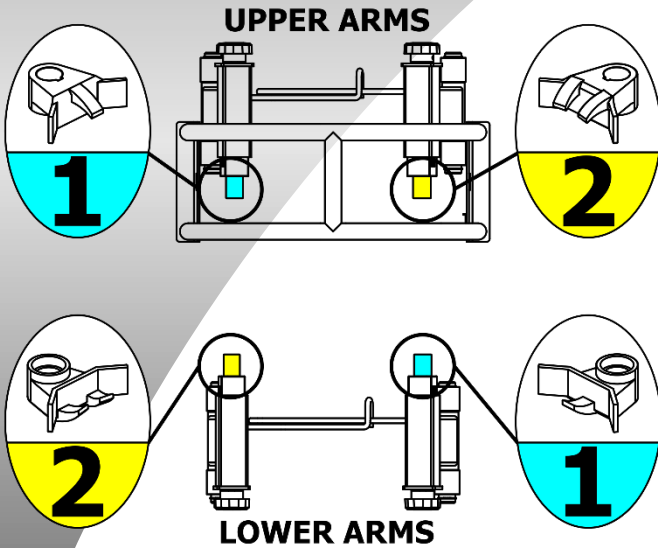

DO NOT INSTALL CLAWS ANY WAY OTHER THAN IMAGES ABOVE!



!! WARNING !!

At any time during compression or decompression, a bow or bend to the spring is noticed, **STOP** immediately and reset. Serious injury, property damage, or death may result from continuing.



Proper placement of claws is imperative to keep a spring or strut assembly in the proper position while compressing. Claws should be in opposite positions top and bottom. Two single finger claws should NEVER be installed together on the same level or same side of the strut compressor.



Please scan the QR barcode for further instruction & videos on how to setup your equipment:

TROUBLESHOOTING

SYMPTOM	PROBLEM	FIX
Not able to engage clamps on spring	1. Spring doesn't have enough coils 2. Spring length is too short	Remove upper clamps and replace with optional Diamond plate adapter (PN: 20-8000)
Noise or noticeable difficulty compressing spring	Screw shaft is not lubricated	Lubricate screw shaft

STRUT ASSEMBLY LIMITATIONS

The following parameters outline the most common spring dimensions that the strut compressor will accept.

ACTUATION STROKE (spring compression).....	9 7/8"
FINGER STROKE (clamp adjustment with knob).....	2 5/8"
MAXIMUM DISTANCE BETWEEN UPPER & LOWER CLAMPS.....	12 1/2"
MAXIMUM SPRING DIAMETER.....	Ø11 1/2"
MINIMUM SPRING DIAMETER.....	Ø3 1/2"
MAXIMUM COIL DIAMETER (spring wire).....	Ø1 1/2"
MINIMUM DISTANCE BETWEEN SPRING COILS.....	7/8"

REPLACEMENT PART DIAGRAM & PART NUMBER GUIDE

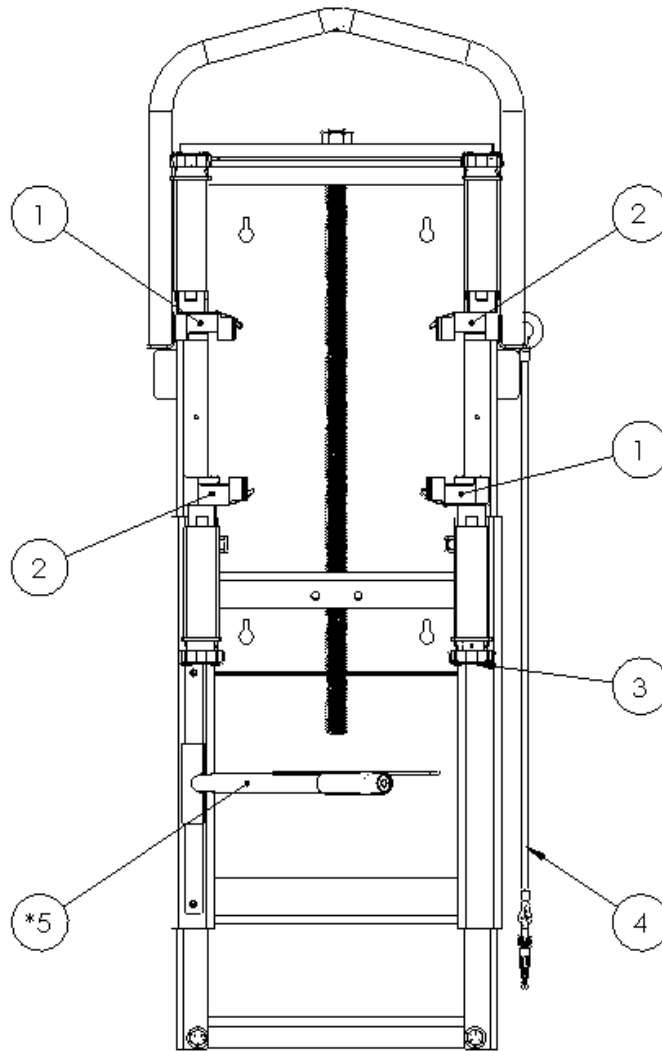

#	PART NUMBER	DESCRIPTION	QTY
1	8000-7	TWO FINGER CLAMP	2
2	8000-13	SINGLE FINGER CLAMP	2
3	DB-8000-070	ADJUSTING KNOB	4
4	DB-8000-301	RETENTION CABLE	1
*5	DB-8000-050	STRUT SUPPORT ASSEMBLY	1

* IDENTIFIES AN OPTIONAL ACCESSORY

WARRANTY INFORMATION

Your MSC-1000 Strut Compressor has been thoroughly tested and is guaranteed for a period of 12 months from the date of delivery. Under the terms of this guarantee, all components which are proven to be defective within the warranty period will be repaired or replaced free of charge. Our technical service assistance is the sole authority in determining whether or not defects come under the coverage of the guarantee. The guarantee excludes all responsibility on the part of Quality Stainless Products (QSP) for direct or indirect loss or damage to persons or things deriving from incorrect operation or servicing of this product. This guarantee is limited to defects in materials, workmanship and assembly, and excludes all components subject to normal wear. Furthermore, the guarantee excludes return shipping of defective part(s) to QSP. QSP will however ship the replacement part by standard ground service at no charge.

QSP will not assume liability for damages caused by improper use of the strut compressor including using the device for something other than its intended use.

Parts Department 888-473-5378

TYPE: Strut Compressor

MODEL: MSC-1000

Serial Number:

Please retain this document for reference when calling Technical Assistance.

INSTALLATION & USE OF OPTIONAL DIAMOND PLATE KIT

The optional diamond plate kit (PN: 20-8000) is used on heavy duty springs, or where the assembly is not able to be properly installed into the unit using the upper and lower claw hooks.

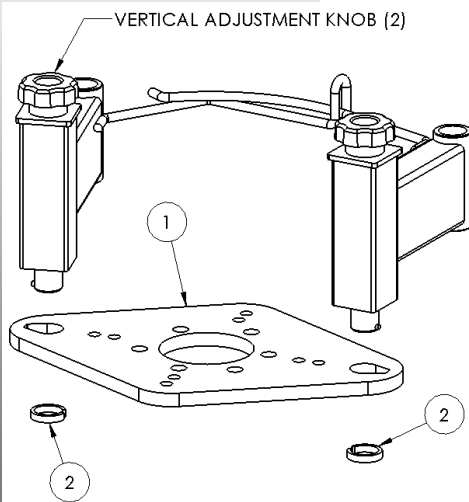

WHILE HOLDING THE DIAMOND PLATE (ITEM #1) IN PLACE, ALIGN OPENING IN ITEM #2 WITH BOSS ON THE SHAFT OF THE VERTICAL ADJUSTMENT ARM. LIFT ITEM #2 INTO PLACE BELOW THE DIAMOND PLATE THEN ROTATE 180° SO THAT THE OPENING NO LONGER ALIGNS WITH BOSS.

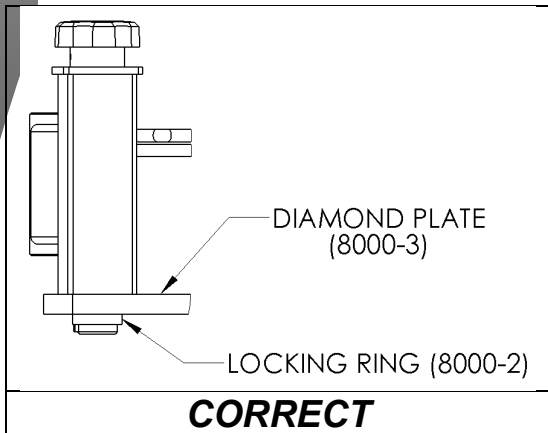

AFTER INSTALLING BOTH LOCKING RINGS, ENSURE THAT THE DIAMOND PLATE IS DRAWN TIGHTLY TO THE VERTICAL ADJUSTMENT ARMS WITH NO GAPS

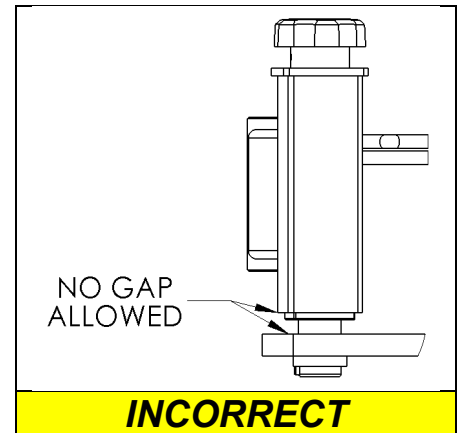

Continued on next page...

INSTALLATION & USE OF OPTIONAL DIAMOND PLATE KIT (continued...)

The optional diamond plate kit (PN: 20-8000) is used on heavy duty springs, or where the assembly is not able to be properly installed into the unit using the upper and lower claw hooks.

Double check that the diamond plate is drawn tight to the upper arms using the vertical adjustment knobs.

Install a double claw hook on each of the lower two arms.

Position the strut assembly onto the lower arms using the vertical adjustment knobs to orient the strut assembly in a vertical position.

If the strut assembly has studs that do not align with a pattern in the diamond plate, install the diamond plate stud spacers over the studs on the strut assembly.

Slowly raise the strut into position with the compressor and once the top end (or stud spacers) contacts the diamond plate, verify that both lower double claw hooks are contacting the spring.

Install (4) custom placement pins to secure the top end of the assembly & prevent it from moving under compression.

Compress the strut assembly.

Position the strut support weldment (third hand) under the assembly to hold it in place.

Remove the fastener from the top of the unit and lower the strut compressor relieving the spring.

Reverse steps to reassemble.

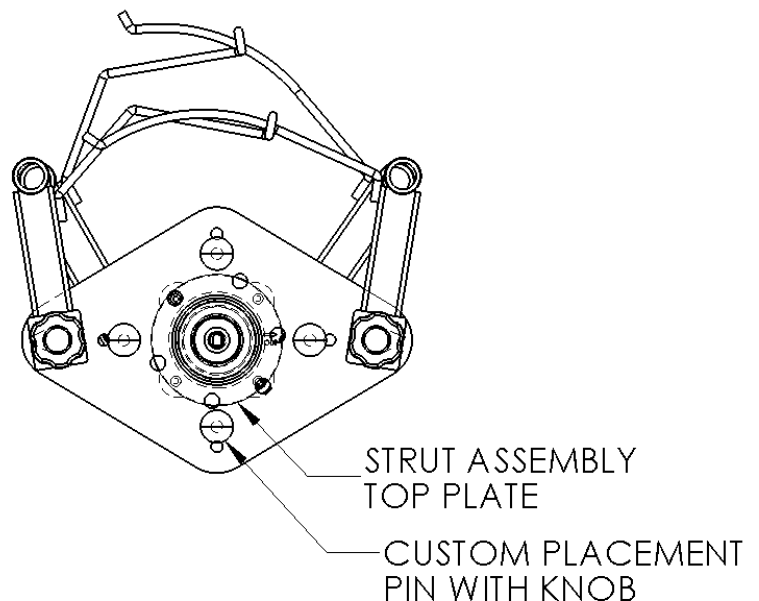
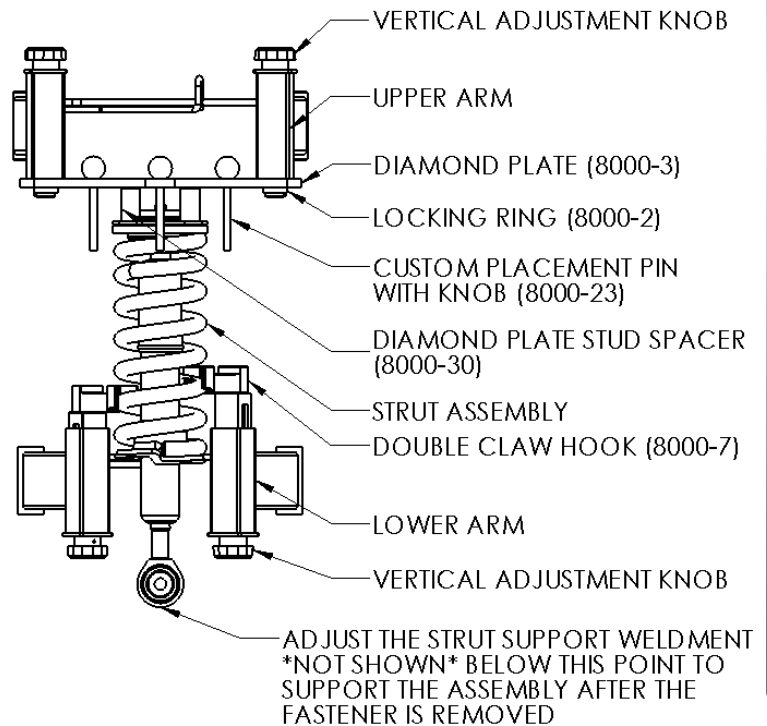

MAINTENANCE LOG

Use the table below to log part replacements and preventative maintenance to your equipment.

MAINTENANCE ITEM	COMPLETED BY	DATE

NOTES: