

Overhead Two Post Lift

NW-2-9KACD

Manual

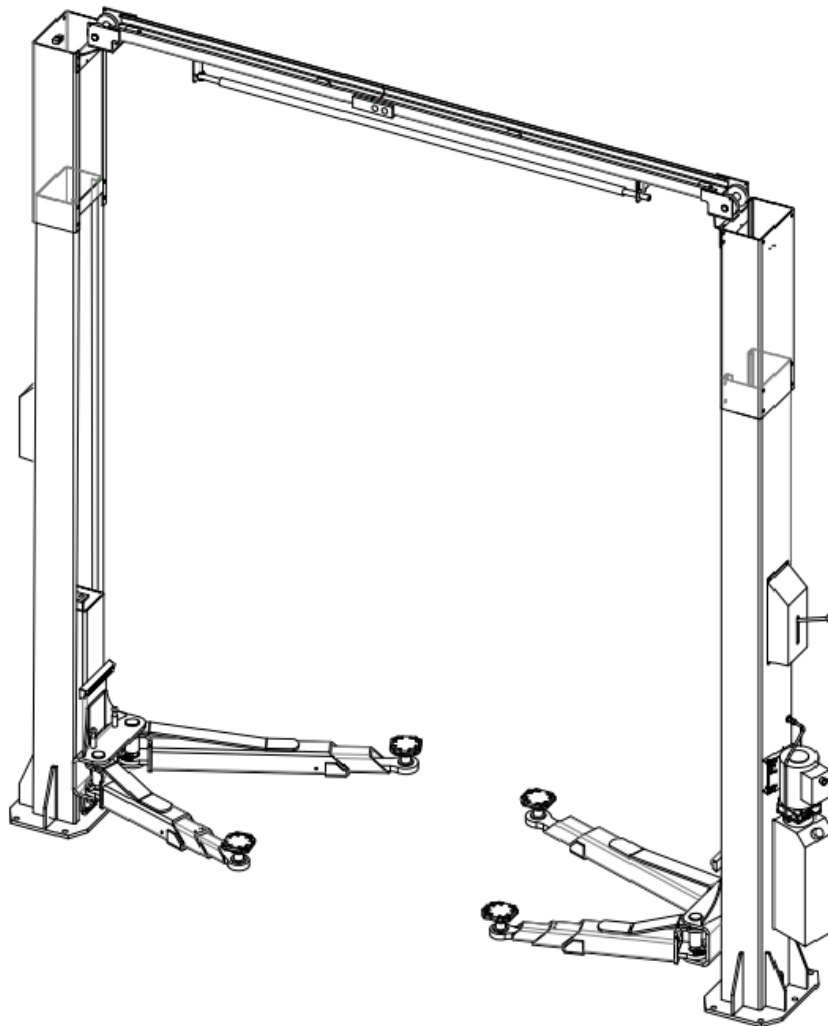

Note: Please read the manual carefully before installing and operating.

Lift Operation and Precautions (Non-professionals who have not been trained and approved are not allowed to operate the lift)

Operation Instructions:

- 1、 Please read the instruction manual carefully before operating and using the lift.
- 2、 Regularly inspect and maintain the lift in accordance with the requirements of the instruction manual.
- 3、 Do not use the lift when it is damaged or in a state of repair.
- 4、
- 5、
- 6、 The lift is not allowed to lift anything other than the vehicle.
- 7、 Hands, feet and clothing should be protected from being pressed or snagged by the lift.
- 8、 Make sure all safety locks are in good condition and do not alter or damage their safety devices.
- 9、 If there is a risk of falling from the lifting vehicle, the personnel on site must be evacuated quickly.
- 10、 It is forbidden to operate the lift when there are people in the lifted vehicle. Unrelated personnel should not be in the lifting work area during operation.
- 11、 When it is found that the anchor bolt is loose or there are cracks in the concrete around it, the use of the lift should be stopped immediately, and the lift should be reinstalled according to the regulations.
- 12、 It is forbidden to overload the use of the lift. The weight of the lifting vehicle shall not exceed the limited load capacity of the lift.
- 13、 When lifting, the lifting arms must be placed in a suitable position under the vehicle to keep each arm supporting the same weight.
- 14、 Each arm divides the total weight of the vehicle as evenly as possible.
No more than 2250# per arm
- 15、 Avoid moisture on the motor at the hydraulic station.
- 16、 When you leave the lift or are working on the vehicle on the lift, you must place the lift in place of the mechanical safety lock.
- 17、

Inspection & Repair (Monthly Inspection)

- 1、 Check the condition of the arms frequently, and replace it if it is deformed or sagging.
- 2、 Check the connection of the Cables to see if it is loose, bent or broken, Whether the lubrication is good. 3
- 3、 Check the joints of all bolts, nuts, and screws to make sure they are tightened.
- 4、 Make sure all safety locks are in a safe position during operation.
- 5、 Lubricate the carriages with a small amount of lubricant every month.
- 6、 Check the strength of the anchor bolts and the connection.
- 7、 Check if the electrical switch of the lift is working properly.

Raising the lift goes up:

- 1、 Before using the lift, you need to read and understand the operating instructions.
- 2、 Support the bracket in the lifting position recommended by the car manufacturer.
- 3、 The vehicle should be parked in the appropriate position between the two columns, so that the center of gravity of the vehicle is kept in the center position between the two columns as much as possible, so as to ensure that all the supporting pads are smoothly supported.
- 4、 Be very careful when using arm height extensions and the extensions for each arm of the lift should not exceed 220mm, and they should be consistent.
- 5、 When the pad on the arm of the lift is placed, the lift is raised so that the pad touches the corresponding position under the vehicle.
- 6、 Lift the vehicle to any of the locks and check its stability.
- 7、 When working on the vehicle, ensure the stability of the lift.

Lowering the lift:

- 1、 First check under the lift to ensure all is clear.

- 2、 To lower the lift, first raise it so that it can be unlocked.
- 3、 Pull & hold the lock release lever. Press the lowering valve handle until the lift is fully on the ground & the arms are able to swing free of the vehicle.
- 4、 Once the lift is fully on the ground , swing the arms away from the vehicle to their stored positions

Tableofcontents

- 1、 Common Information 4
- 2、 Tools..... 5
- 3、 Packages..... 6
- 4、 Product Structure and specifications..... 7-8
- 5、 Installation 9-12
 - 5.1、 Structure 13
 - 5.2、 Installation..... 13
 - 5.3、 Exploded drawing 14-15
 - 5.4、 Parts List..... 15-17
- 6、 Testing and Operating..... 18
- 7、 Common troubleshooting 19

1、 Common Information

The chapter includes warning instructions for the correct operation of the lift and to prevent injury to the operator or objects. Instruction manuals are written for the use of the lift by technicians and maintenance professionals.

Instruction manual is part of the complete machine and must be kept with the machine throughout its lifetime.

Read each section of the instruction manual carefully before operating the lift, as you will be provided with the following information:

- Safety of people
- Safety of lifts
- Safety of the lifted car

It is not possible for the manufacturer to indicate all possible problems, damage, accidents, etc. in the operating instructions.

	Any person unfamiliar with the operating rules and instructions is prohibited from operating the machine.
---	---

1.1 Instruction manual storage

For better use of the instruction manual, please follow the suggestions below:

- Put it near the lift and easy to get.
- Store in a humidity-proof place.
- Proper use without damage.

Manual is part of the complete lift. If the lift

1.2 Fault liability

	In the event of a malfunction follow the clear instructions contained in the following sections
---	---

1.3 Operational Safety Warning

When operating the machine, the operator must not be influenced by sedatives, drugs or alcohol.

	Before operating the machine, the operator must familiarize himself with the position and function of all controls as well as with the machine characteristics described in the chapter "Commissioning and operation of the machine".
---	---

1.4 Warning

	Unauthorized changes to the machine that may damage objects and persons will not be the responsibility of the manufacturer. Do not move or disable the safety devices, as this will violate the safety regulations.
---	---

	The use of impure parts may cause damage to persons or objects.
---	---



Any use different from that specified by the machine manufacturer must be strictly prohibited

Statement of Warranties and Limitations of Liability

The manufacturer has spent a lot of energy in compiling the instruction manual, trying to ensure that the information in the instruction manual is correct, up-to-date and complete. But it is not easy to write without any mistakes. At any time, the manufacturer reserves the right to make appropriate modifications to the instructions due to the technical improvement of the products.

2、

The following tools and equipment are needed:

- Hoist or Forklift (optional)
- Metric Sockets and Open Wrench set
- Two 10' to 12' step ladders
- Vise grips
- ISO 32/46 Light Hydraulic Oil (approx. 12 quarts)
- Metric Allen Wrenches
- Tape Measure
- Torque wrench with socket for anchors
- 4' Level • Teflon Tape
- Rotary Hammer Drill with **18mm Drill Bit.**

3.1 Packaging

The lift is divided into several parts to be packaged and delivered:

- lifting brackets, equipped with hydraulic cylinders, safety locks, arms, hydraulic oil hose, balance steel cable etc.
- anchor bolts, parts of fasteners, parts of accessories, etc. as detailed in the accessory box.
- 1 power unit with hydraulic pump station

3.2 Lifting and transport

When equipment is loaded or unloaded in transit or transported to site, ensure that appropriate lifting methods (cranes, forklifts, etc.) are used. Consideration should be given to package size, weight, gravity centre and vulnerable parts to ensure safe lifting and transport to avoid dropping.

3.3 Delivery and acceptance

Due to the possibility of damage to the machine during transport and storage, delivery is subject to acceptance inspection in the configuration and factory condition specified by the manufacturer at the time of ordering; if damage occurs in transit, users must immediately inform the transporter who caused the problem.

Unpacking must be careful, personnel should keep a safe distance to avoid injury, should also prevent the lift parts falling damage...

4. Structure and specifications

NW-2-9KACD Specifications

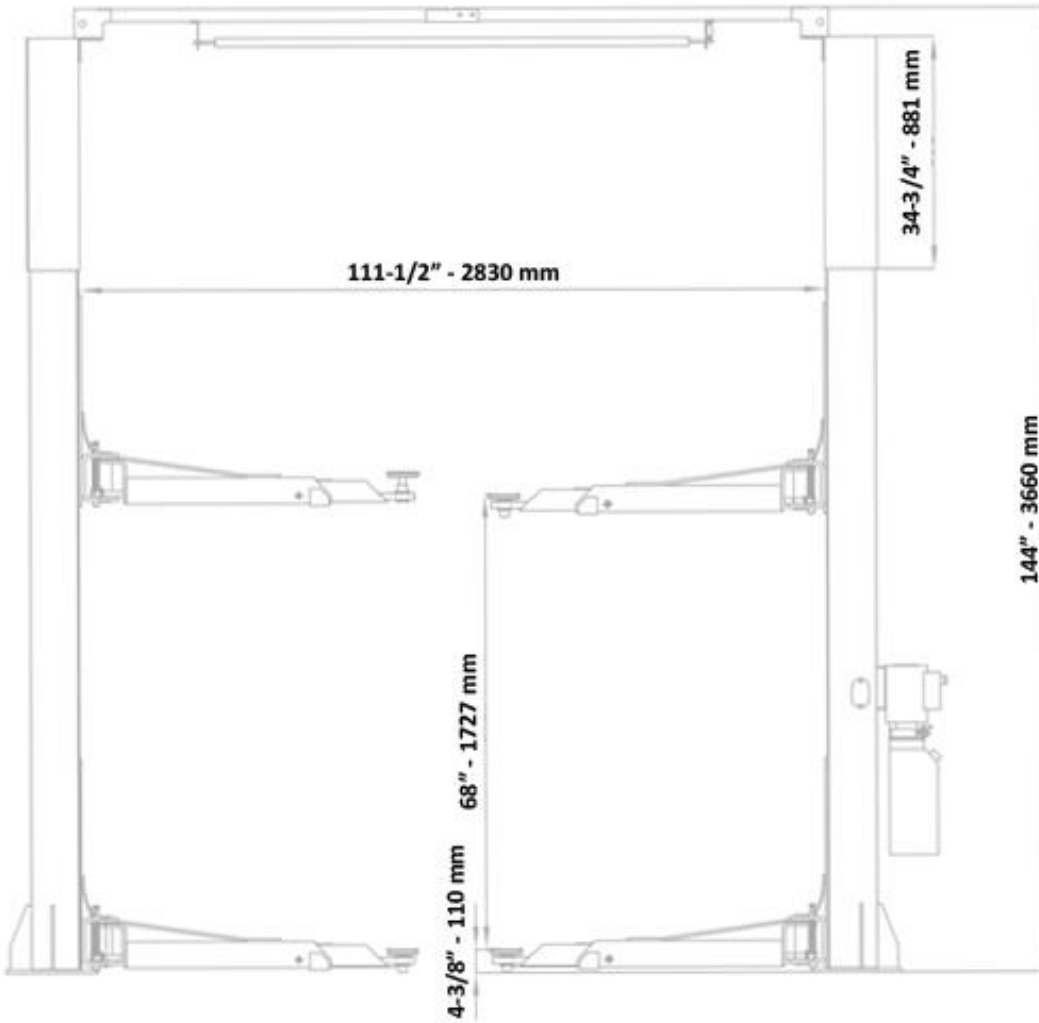

Figure 1

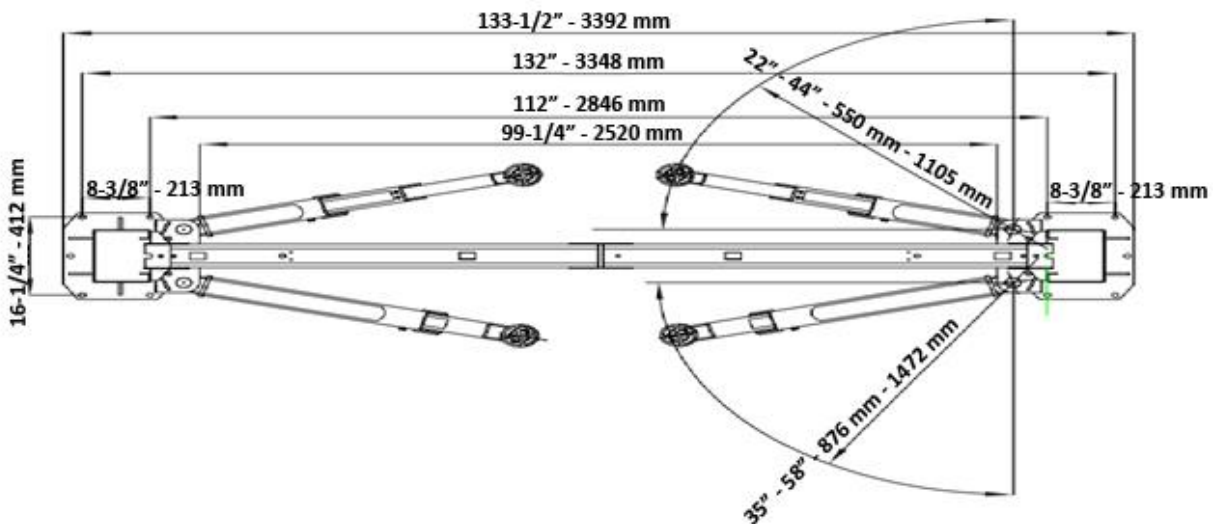
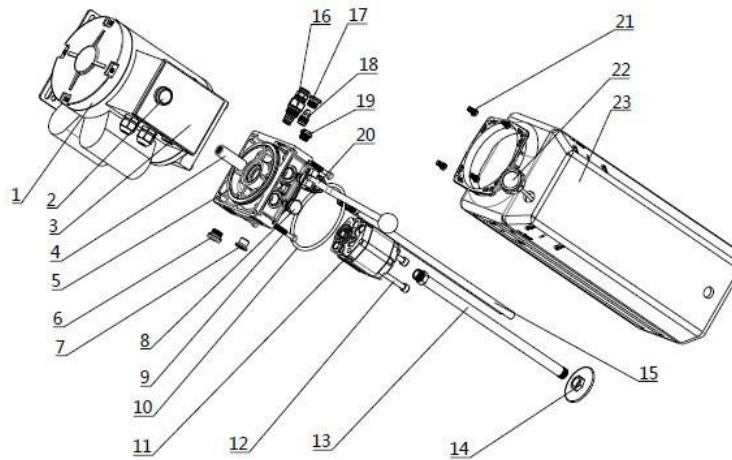

Figure 2

a. Hydraulic power unit schematic



b. Detailed list of hydraulic parts

No.	Descriptions	Parts No.	Quantity	Remark
1	Motor	YL220220-2-60	1	
2	Starting Button	YW1B-M1E10	1	
3	A/C Contactor	HLR6100-2ATNBCF	1	
8	Check Valve	CV-01	1	
14	Suction Filter	Fs-03b		
15	Oil Return Pipe	RU12-380		
16	Relife Valve	RV-01		
20	Lowering Valve	MV-01	1	
22	Oil Reservoir Cap	FC-04B	1	
23	Plastic Oil Reservoir	11L-TP120A460-VH	1	
24	Starting Capacitor	C1 YL220360-2-60 ETL	1	
25	Running Capacitor	C2 YL220360-2-60 ETL	1	

5. Installation of the equipment and breakdown of accessories

Installation Drawing (SYMMETRICAL)

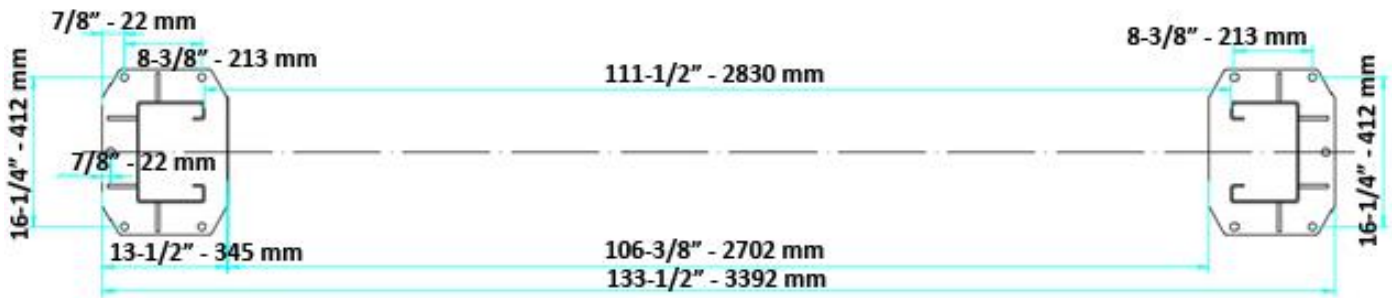

Figure 3

Installation Drawing (ASSYMETRICAL)

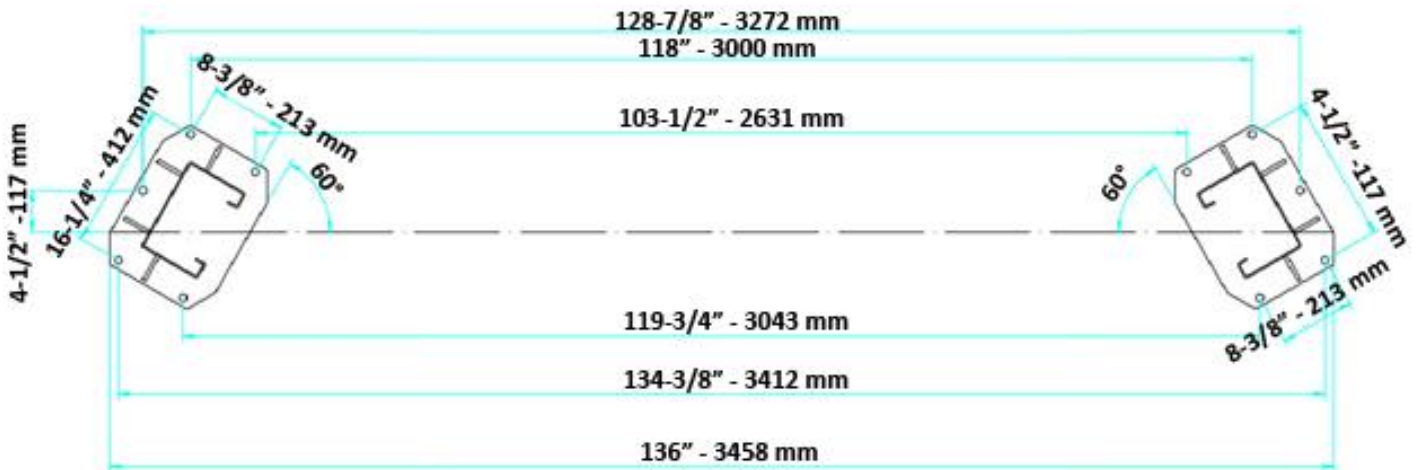
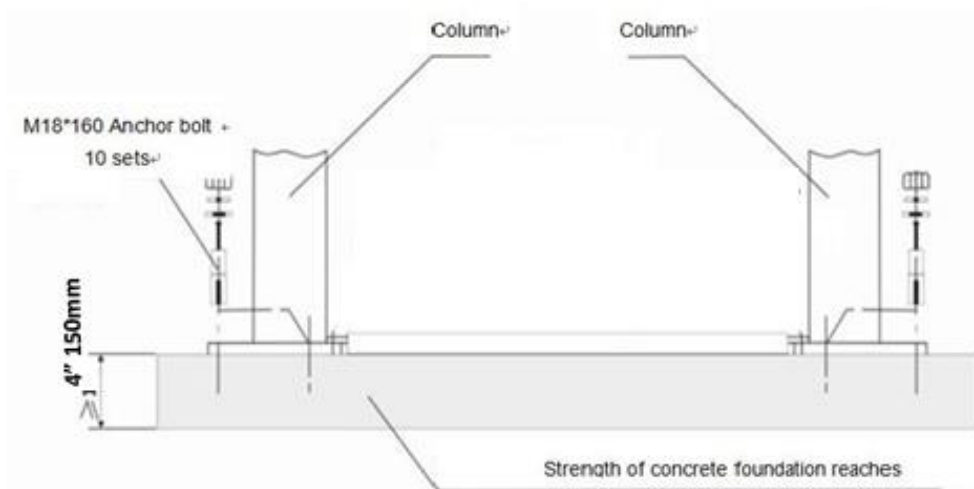

Figure 4

Equipment installation foundation requirement



Note: foundation concrete strength must be 3000psi or greater.

Figure 5

Assembly Diagram

oil hose assembly schematic

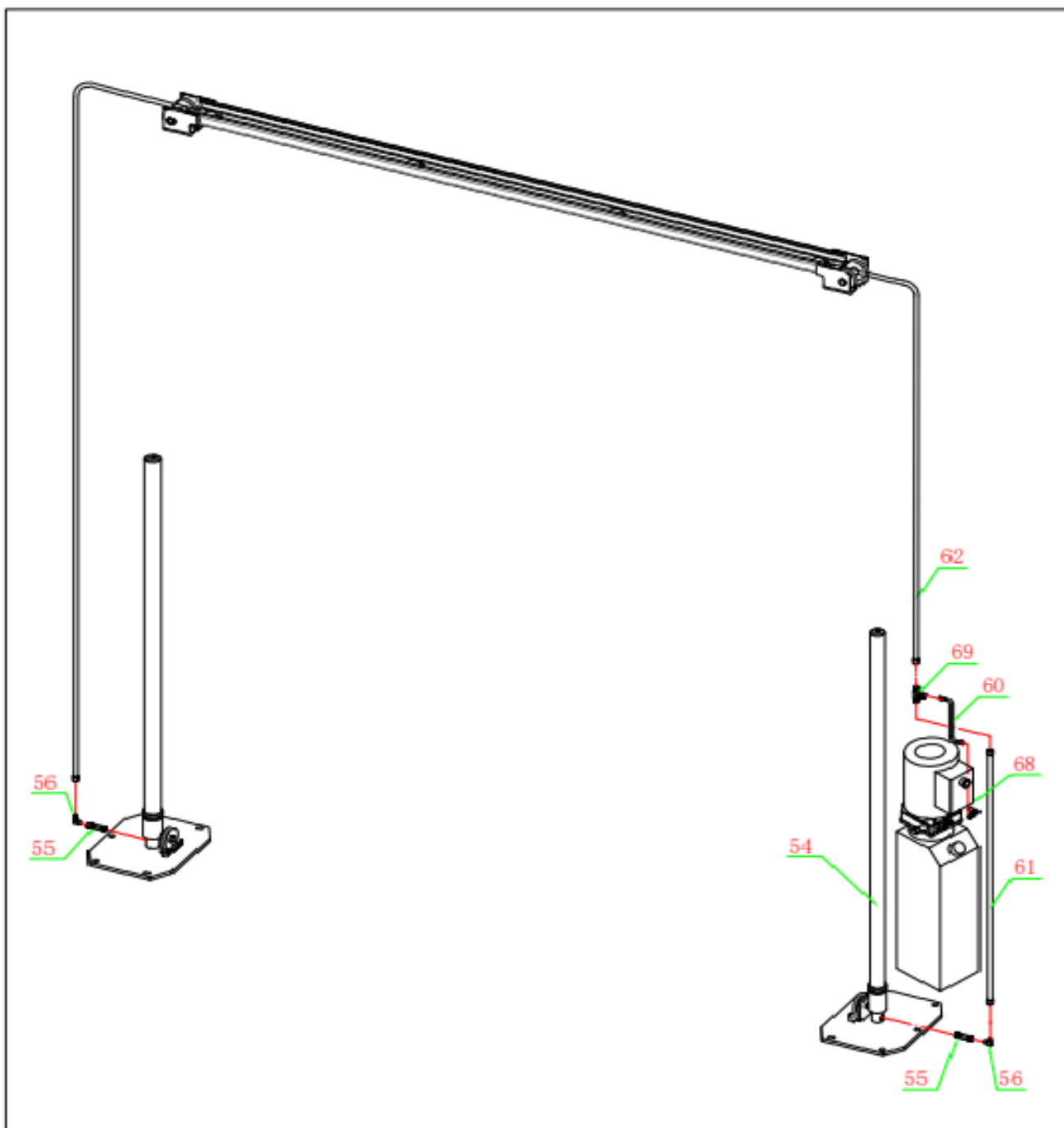

Figure 6

Steel cable installation schematic

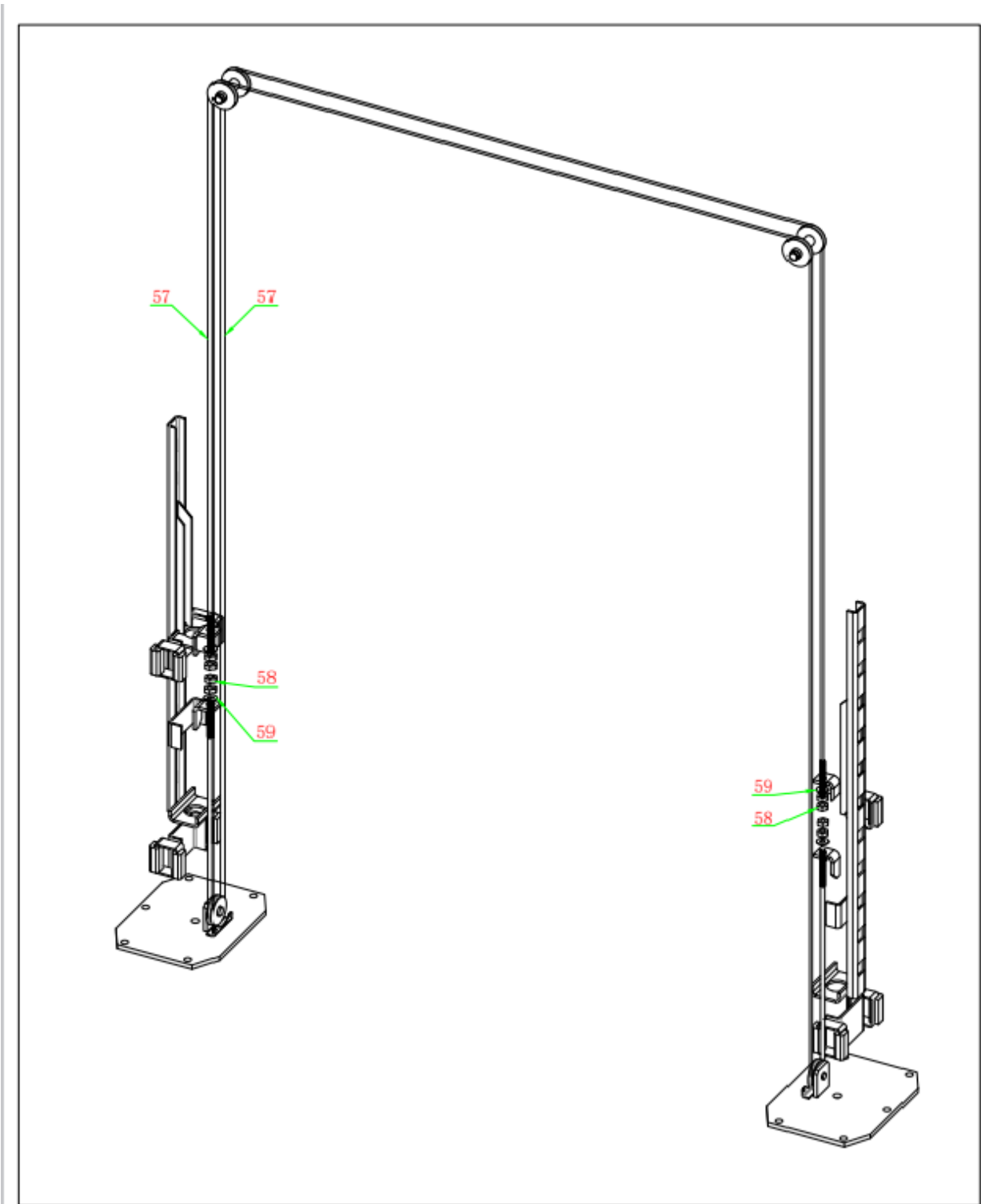

Figure 7

Carriage lock gear installation schematic

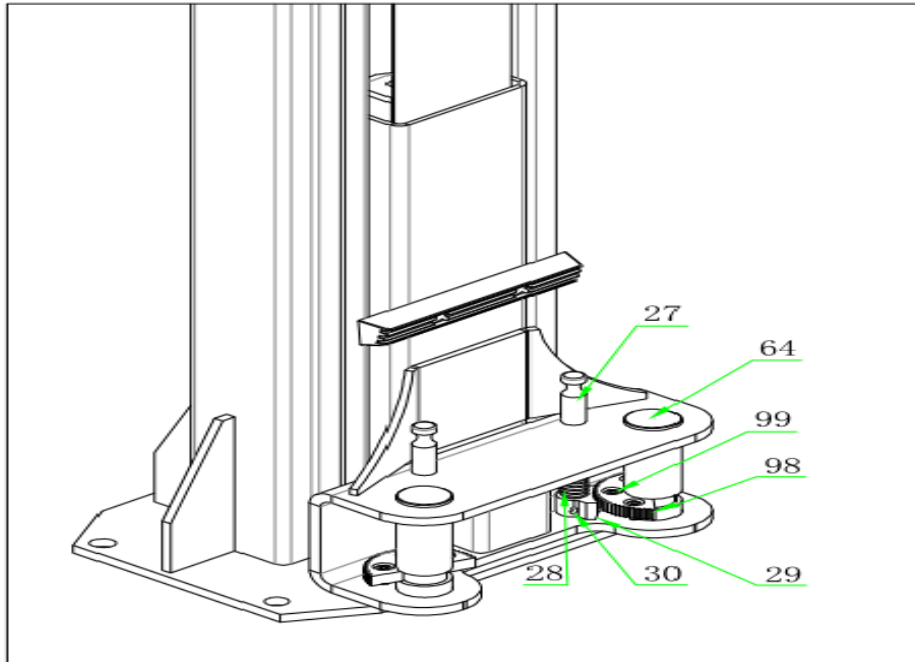

Figure 8

Unlocking steel cable installation schematic

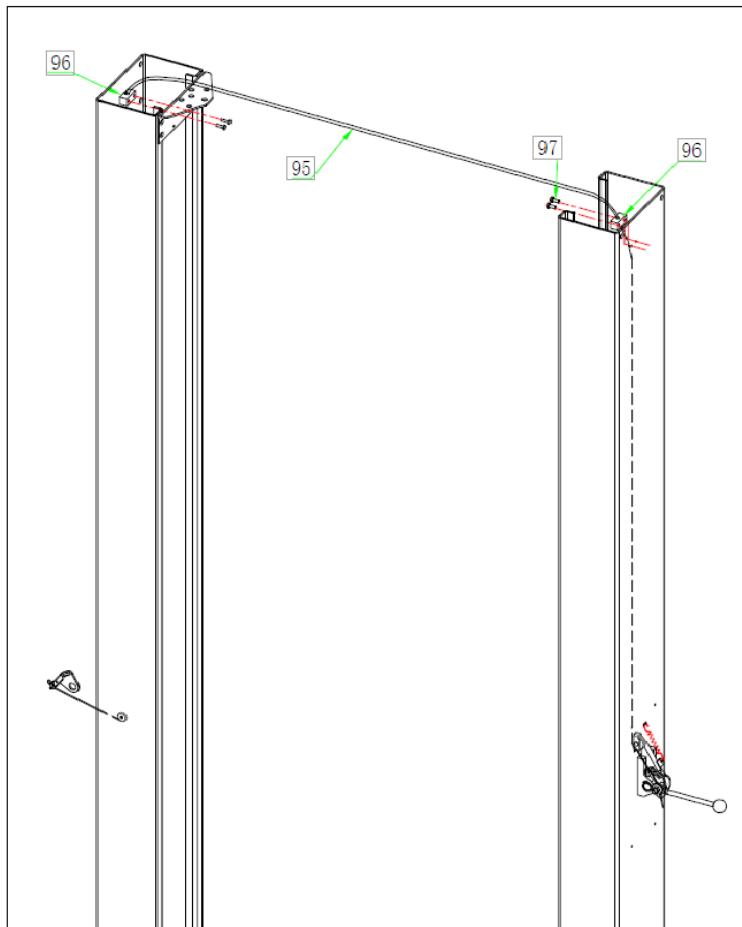

Figure 9

5.1 Main structure

Lifting mechanism: hydraulic cylinders are installed in the two columns, when the hydraulic oil enters the lower chamber of the piston rod, the cylinder barrel moves upward and acts directly on the sliding table through the cylinder barrel to make it rise.

Supporting mechanism: when the car enters the working area, through the four rocker angle and expansion of the adjustment, so that the support pad moved to the position of the effective support point of the car, but also according to the height of the car chassis, the appropriate adjustment of the height of the support pad, the balance mechanism: in the process of lifting and lowering the car, the hydraulic cylinder is installed in the two columns. Sleeve and anti-pressure device are available for optional use (depending on specific sales).

Balance mechanism: In the process of car lifting and lowering, in order to keep balance, two wire ropes interconnect the two sliding platforms and force the sliding platforms to move synchronously.

Safety locking mechanism: both carriages are installed with safety locks, after the car is raised, automatically lock a certain position. When the car is lifted up, the safety locks will automatically lock a certain position to ensure that the car stays in a reliable position and will not fall down when it starts working. The installation of two sets of safety locks provides double insurance.

5.2 Installation Precautions for Equipment

- Pour the foundation as shown in the basic drawing (Figure 4). After the concrete is completely solidified, install and assemble the equipment. Fasten with M18*160 expansion bolt. After fastening, the two upright posts are vertical to the ground plane. Ensure the safety of the equipment when it works.
- Assembly points: (Figure 3 to Figure 6)
- If there is an extension column, connect the extension column (auxiliary column) with the main column (export type).
- The two main columns are erected, and the positions of the two columns are determined by the bottom plate or beam. There is a beam type to put the beam and the top wheel parts in place and fasten them with bolts.
- Drop the two carriages to the first lock, install the nut on the wire rope as shown in the figure.. Start adjusting the nut to adjust the tension of the two steel ropes to the best state. (Figure 6)
- Lithium grease for lubrication is coated on the guide rail of the inner cavity of the two columns.
- The power connection will be determined according to the requirements of the motor nameplate. It is required to install a main power switch beside the lift to cut off the power supply in case of maintenance and emergency.
- Check the tension of the two wire ropes to ensure the synchronous movement of the two carriages .
- Heavy load test run: check whether the hydraulic system works normally.

5.3 Product Breakdown Diagram

Exploded diagram

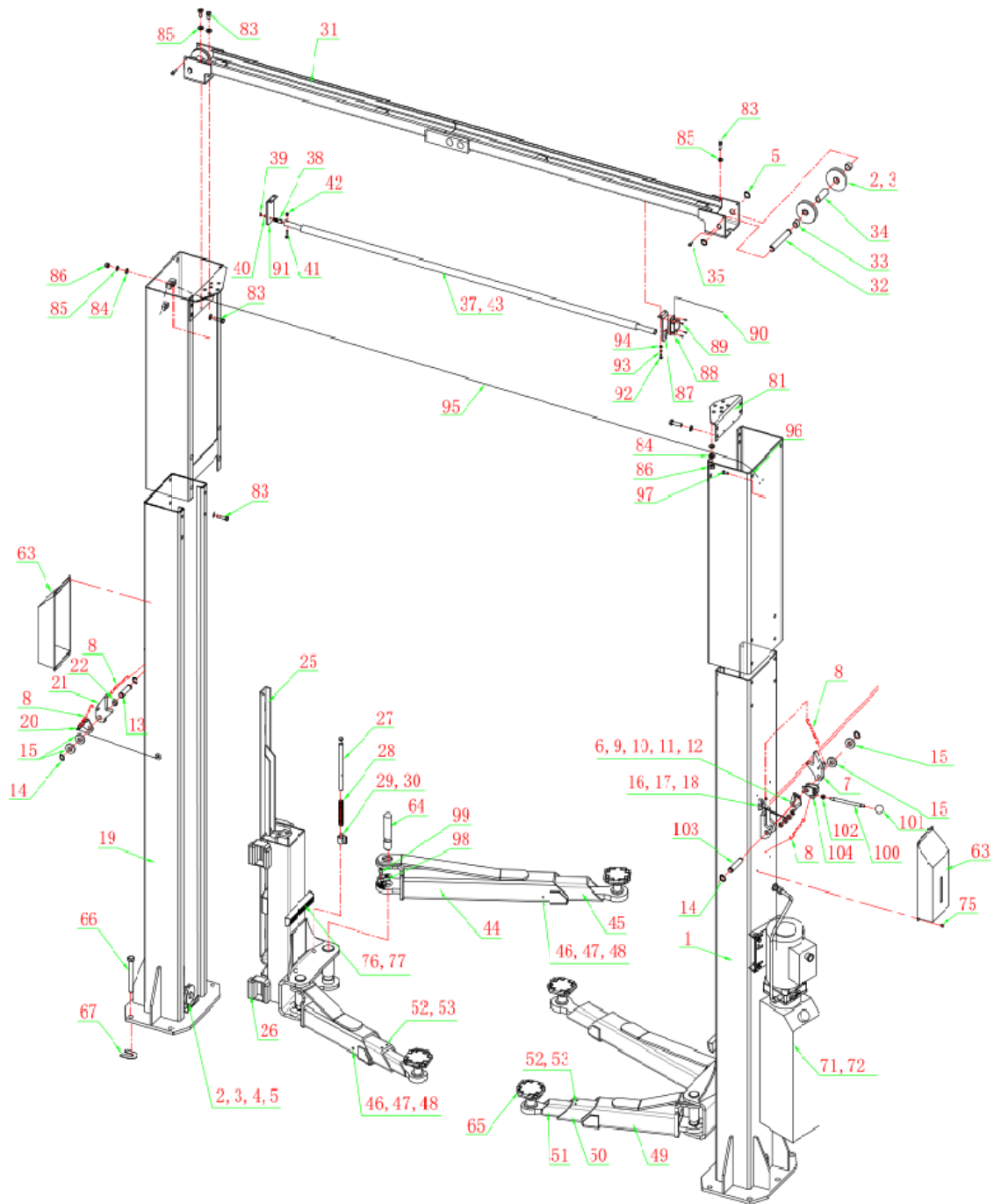

Figure 10

Safety lock exploded diagram

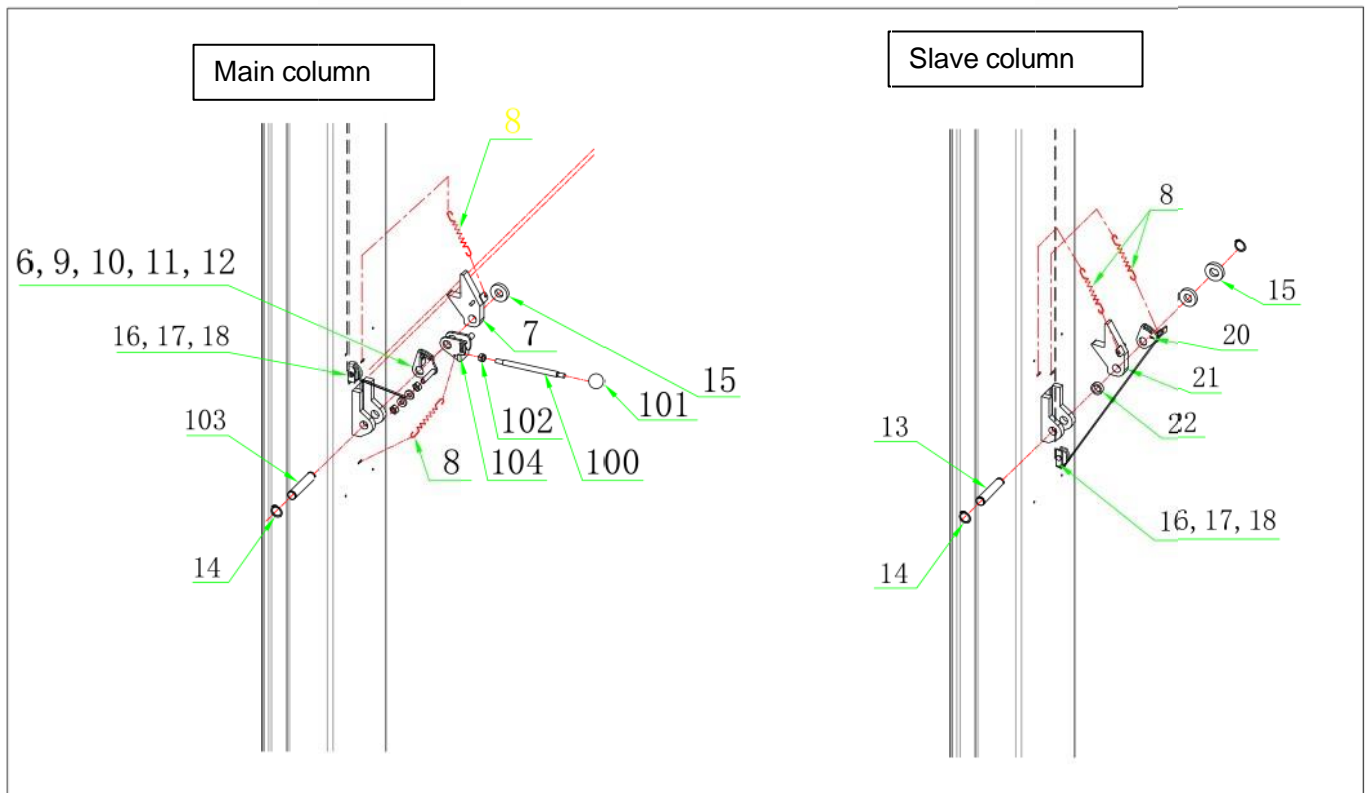

Figure 11

5.4 Parts List

NW-2-9KACD Parts list				
Drawing No.	Descriptions	Parts No.	Qty.	Remark
1	Main column	PRO-X700-1100	1	
2	Pulley	YSJ-4000-01-02	6	
3	Pulley Sleeve	YSJ-4000-01-03	6	
4	Spacer	30400-1005C	2	
5	Snap ring	φ25	6	
6	Rotating plate	PRO9N2-1020	1	
7	Safety lock	PRO9N2-1010A	1	
8	Spring	PRO9N2-1008A	4	
9	Screw	M6*30	1	
10	Hex Nut	M6	1	
11	Hex Nut	M10	2	
13	Lock shaft	TPF-9S1-1001	1	
14	Snap ring	Φ10	4	
15	Flat washer	Φ10	4	
16	Roller wheel	TPF9S1-1002	2	
17	Pin	φ *25	2	
18	Cotter pin	φ2.5*20	2	

19	Slave column	PRO-X700-2100	1	
20	Rotating plate	PRO9S1-1050	1	
21	Safety lock	TPF9S1-1040	1	
22	Sleeve	TPF9S1-2001	1	
25	Carriage	PRO-X700-1100	2	
26	Slide block	YSJ-4000-04-01-01	16	
27	Lock pin	PRO9S1-4001	4	
28	Spring	YSJ-4000-04-07	4	
29	Lock Gear	30400-5014C	4	
30	Cotter pin	φ5*35	4	
31	Crossbeam	PRO9S1-5010	1	
32	Pulley pin	YSJ-4000-05-01	2	
33	Sleeve	YSJ-4000-03-02	4	
34	Sleeve	YSJ-4000-05-02	2	
35	Screw	M6*35	4	
37	Limit bar	HPRO-5003	1	
38	pin	HPRO-5004G	1	
39	Hex Nut	M8	1	
40	Spring washer	φ8	1	
41	Hex bolt	M6*30	1	
42	Nut	M6	1	
43	Limit bar plastic cover		1	
44	2-stage arm(outer tube)	YSJ-4000-06-10	2	
45	2-stage arm(inner tube)	YSJ-4000-06-20	2	
46	Screw	M10*16	4	
47	Spring washer	φ10	4	
48	Flat washer	φ10	4	
49	3-stage arm(outer tube)	YSJ-4000-07-10	2	
50	3-stage arm(mid tube)	YSJ-4000-07-20	2	
51	3-stage arm(inner tube)	YSJ-4000-07-30	2	
52	Bolt	M8*12	4	
53	Washer	φ8	4	
54	Hydraulic cylinder	N11-9100X	2	
55	Fitting	PRO9S1-8001	2	
56	Fitting	HPRO-9802-02	2	
57	Steel cable	PRO9S1-9001	2	
58	Nut	3/4"-16UNF	8	
59	Flat washer	Φ20	4	
60	Oil hose	PRO-X700-9007	1	
61	Oil hose	PRO-X700-9002	1	
62	Oil hose	PRO-X700-9003	1	
63	Plastic cover	PRO9S1-9200	2	
64	Arm pin	YSJ-4000-04-09	4	
65	Round adapter	YSJ-4000-09-10	4	
66	Anchor bolt	M18*160	10	
67	Plastic shim	30400-1025	10	

68	Power unit	1011-05D	1	
69	Fitting	HPRO-Y002	1	
76	Rubber stopper	HPRO-4002	2	
77	Bolt	M8*20	4	
81	Angle iron	YLJ-4000-09-01	2	
83	Bolt & washer & nut	M12*40	20	
86	Nut	M12	12	
87	Angle iron B	HPRO-5002	1	
88	Limit switch	YBLX19-001	1	
89	Bolt	M3*10	4	
90	Wire	2*0.75 ²	1	
91	Angle iron A	HPRO-5001	1	
92	Bolt	M6*16	4	
93	Spring washer	φ6	4	
94	Flat washer	φ6	4	
95	Lock release cable	TPF9S1-9004	1	
96	Pulley base	TPF9S1-9005	1	
98	Gear	52042C	4	
99	Bolt	M10*16	12	
100	Handle	PRO9N2-1006	1	
101	Handle ball	Sφ35*M10/TM	1	
103	Lock pin	PRO9N2-1001A	1	
104	Handle weldment	PRO9N2-1030	1	

6、 Operation of equipment

a. The moving contact surface of the slide table is filled with a general-purpose lithium grease, which requires all sliding surfaces to be coated from top to bottom.

b. The oil tank of the hydraulic station is filled with No. 46# anti-wear hydraulic oil for the hydraulic system, and No. 32# anti-wear hydraulic oil can be used in areas where the temperature is too low.

● Operation process

a. Check whether the motor power supply is installed correctly.

b. Check whether all connecting bolts are tight.

c. Push up button, the carriage rises: Stop pushing, the carriage stops. To make the carriage descend, first pull the lock release handle on the main column, if it cannot be pulled, Raise the lift until it can. Hold down the handle while disengaging the safety position, the carriage descends. When repairing the car, make sure the lift is resting on the locks.

d. Bleeding the lift

e. This hydraulic system is designed with a bleeding plug, located at the top of the cylinder, raise the carriages to about 1 meter height holding the locks open and loose the bleeding plug, the air would be bled automatically, then tighten the plug after bleeding air, the lift would work stably and smoothly, otherwise, repeat bleeding air.



● Operation process and matters needing attention of automobile repair operation

a. .

b. Precautions:

★ Because of the different positions of gravity centers of various cars, you can know the position of gravity centers of cars first. When the cars enter the elevator, they should make the gravity centers close to the plane formed by the two columns. Adjust the rocker arm so that the bearing point is supported on the bearing surface of the car. Observe the reliability of rocker lock after lifting.

★ When there is a beam hoist, pay attention to the position of the roof and don't get close to the beam to avoid accidents.

★ It is forbidden to open the observation hole cover and insurance cover on the upright post when the machine is turned on.

★ Read the warning signs carefully.

★ Hydraulic valves have been adjusted before leaving the factory, and users are not allowed to adjust them themselves, otherwise users will be responsible for all the consequences.

7. Common Troubleshooting

No.	Failure phenomenon	Troubleshooting
1	Two slide up without synchronization	Insufficient tension on both steel wire ropes, tighten the wire rope nut. (Check and adjustment often after use.)
2	Mechanical safety lock on the column does not work	Re-adjust the tension of the unlocked steel wire rope and lock the wire rope nut.
3	Motor, electrical failure	Cut off the power supply in time, the professional electrician to check, repair and change.
4	Heavy loads can not lift or lift automatically after the slowly down	Electromagnetic unloading valve is not closed tightly, disassemble the valve for cleaning. If damaged, replace it. There are also check valve sealing is not tight, can be cleaned and checked. If damaged, replace.
5	oil leaking from the oil hose joints	Oil seepage from the joint, use raw tape and sealant to connect again. Oil seepage from oil pipe and connector, tighten the oil pipe nut once.
6	lifting and lowering abnormal sound	Apply grease to the sliding guide on the inside of the column and add oil to the rotating part of the wire rope roller. (Excluding abnormal noise from the power unit)
7	Others	If find the working can't be normal, can't solve the problem by yourself, Please contact with our company. Thank you for your cooperation, the Company is warmly at your service.

Wiring The Overhead Shut Off Bar Limit Switch

This is the way the hydraulic power unit is wired from the factory. Wire colors may vary. The prewired "Pig Tail" is on there as a reference point, so the electrical contractor knows which terminal to use. **DO NOT** splice into the "Pig Tail" with extension wire to the breaker box. Remove and discard the "Pig Tail" wires. "Pig Tail" wires are in terminals **2** and **8**. **DO NOT** remove the Push Button "UP" wire on terminal **1** at this time. The power unit is Alternating Current so crossing the wires from the breaker box to the terminals will not create an issue. Be sure that the new wires go into **2** and **6**.

1. Disconnect Electrical Power Before Installation

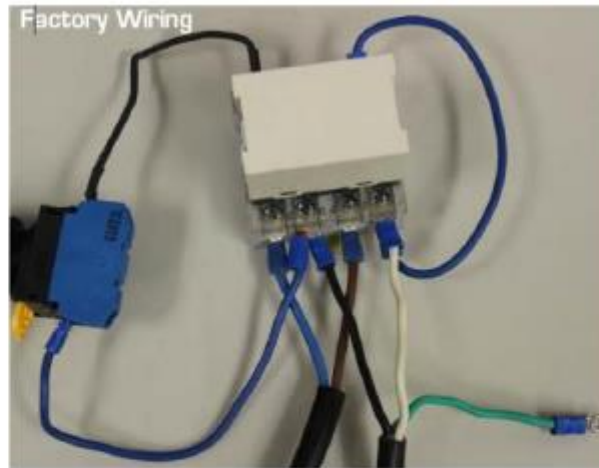

2. Disconnect Electrical Power Before Installation

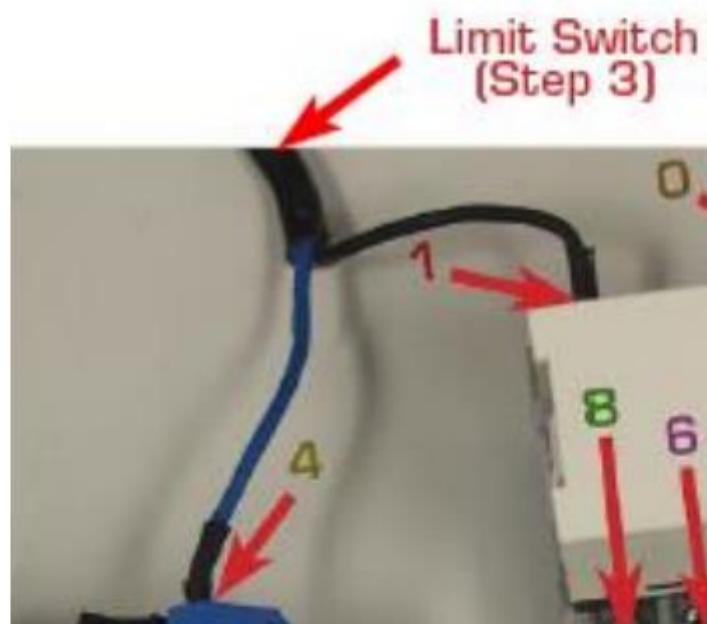

Now you are ready to connect the Push Button "UP" wire to one of the 2 wires remaining in the overhead shut off wire bundle. Remove Push Button "UP" wire from terminal 1. Cut some length off the wire. Wire-nut the Push Button "UP" wire to one of the 2 remaining overhead shut off wires.

3. Disconnect Electrical Power Before Installation

4. Now connect the remaining wire to button terminal 4.

Disconnect Electrical Power Before Installation

Remove Existing Pigtail From Lift (Do Not Operate Until Completed)

1.) Incoming Power

- a.) One hot to terminal 6
- b.) One hot to terminal 2
- c.) Ground to ground

2.) Motor

- a.) One hot to terminal 8
- b.) One hot to terminal 4

3.) Limit Switch

- a.) Cut ground off, **DON'T USE!**
- b.) One hot to Up Button terminal 4
- c.) One hot to terminal 1

4.) Jumpers

- a.) Jumper from Up Button terminal 3 to terminal 6
- b.) Jumper from terminal 2 to terminal 0

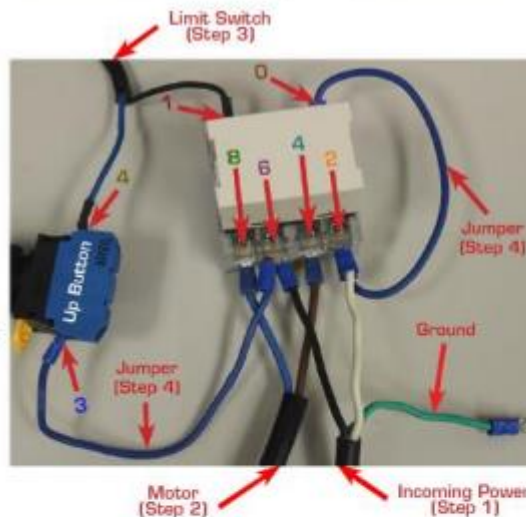

NOTE: Before placing a vehicle on the lift, cycle the Lift up and down several times to ensure that the lock latches engage properly and that all air is removed from the system. To lower the lift, first raise the lift clear of the lock latches and then pull down the safety release handle and depress the hydraulic release on the power unit. If the locks do not engage in sync, tighten the equalizing cable nut on the sided that engages first.