

MaxJax™  
5240 Willis Road  
Theodore, AL 36582  
877-453-0693

# MAXJAX®

## M-6 USER MANUAL

**MODEL: M-6**

**PORTABLE MID-RISE LIFT  
6,000 POUND CAPACITY**

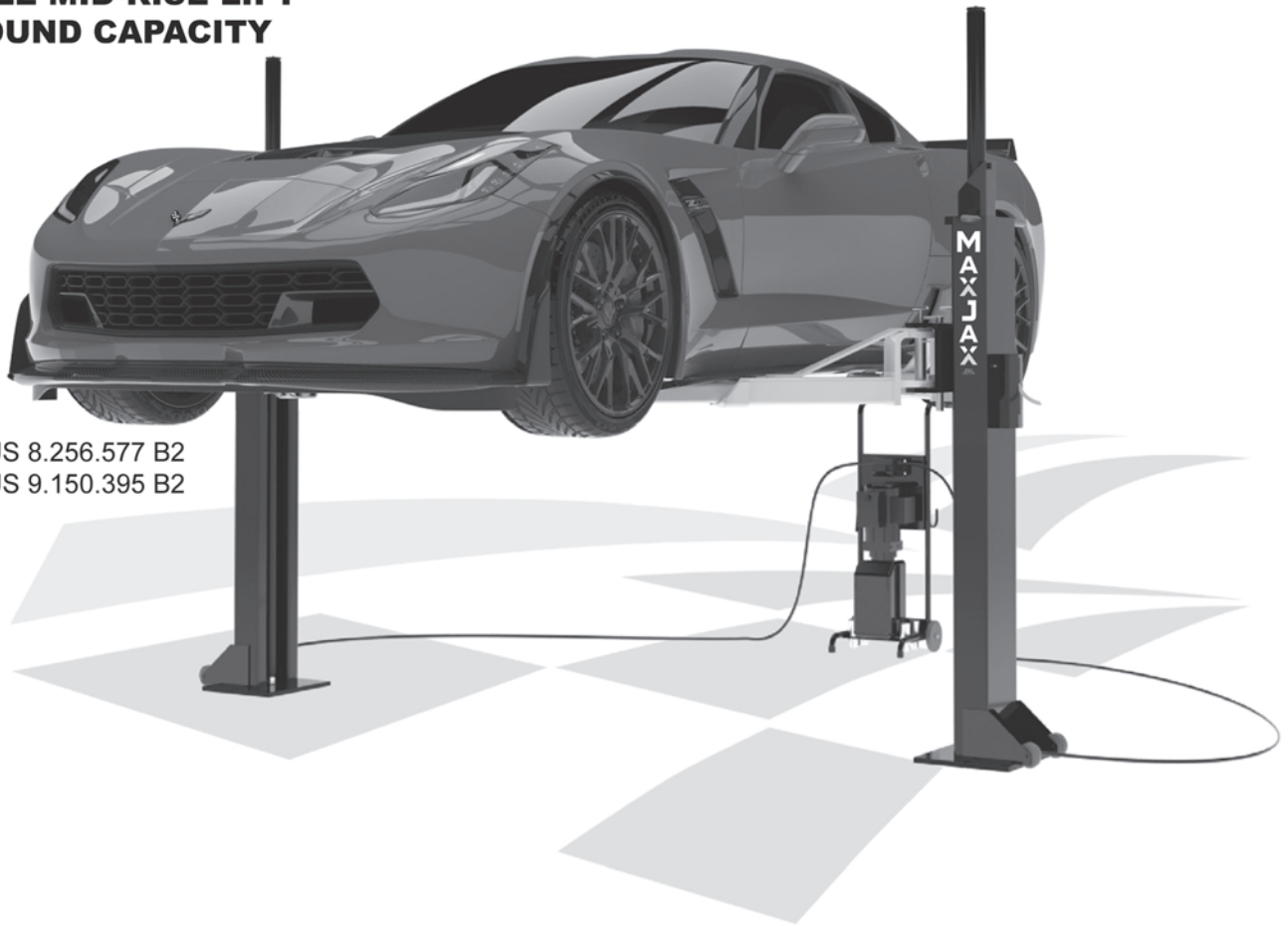

Patent No. US 8.256.577 B2  
Patent No. US 9.150.395 B2

	<p>Reference ANSI/ALI ALIOM safety requirements for installation and service of automotive lifts before installing lift.</p>
--	--

	<p><b>CAUTION</b> The safe operating temperature range for this product is 41° F - 104° F</p>
--	---

	<p>PLEASE READ THE ENTIRE CONTENTS OF THIS MANUAL PRIOR TO INSTALLATION AND OPERATION. BY PROCEEDING WITH LIFT INSTALLATION AND OPERATION YOU AGREE THAT YOU FULLY UNDERSTAND AND COMPREHEND THE FULL CONTENTS OF THIS MANUAL. FORWARD THIS MANUAL TO ALL OPERATORS. FAILURE TO OPERATE THIS EQUIPMENT AS DIRECTED MAY CAUSE INJURY OR DEATH.</p>
--	---

# TABLE OF CONTENTS

IMPORTANT NOTICE / DEFINITIONS OF HAZARD LEVELS	3
IMPORTANT SAFETY INSTRUCTIONS	4 - 5
OWNER / EMPLOYER RESPONSIBILITIES	6 - 7
INSTALLER / OPERATOR PROTECTIVE EQUIPMENT	7
PARTS INVENTORY / ASSEMBLY DIAGRAM	8 - 9
PARTS BAG CONTENTS / PARTS BOX CONTENTS	10
INSTALLATION INSTRUCTIONS / SELECTING SITE / FLOOR REQUIREMENTS	11
INSTALLING HYDRAULIC CYLINDERS	12
MOUNTING THE HYDRAULIC POWER UNIT	13
SITE LAYOUT	14
INSTALLATION OF POWER DROP ANCHORS	15 - 16
CONNECTING HYDRAULIC LINES	17
HYDRAULIC POWER UNIT SET-UP	17
INSTALLING THE LIFT ARMS	18
INSTALLING THE SAFETY RELEASE LATCH	19
BLEEDING THE CYLINDERS	19
FINAL ADJUSTMENTS / POST INSTALLATION CHECK OFF	19 - 20
OPERATION SAFETY	20
LIFT OPERATION / MAINTENANCE	21
LIFT REMOVAL / RE-INSTALLATION.	22
TROUBLESHOOTING GUIDE	23 - 25
GENERAL DISCLAIMER	26 - 27
LIMITED WARRANTY	28
MAINTENANCE RECORDS	29
OVERALL LIFT SPECIFICATIONS	31

## IMPORTANT NOTICE

1. Read this manual thoroughly before installing, operating, or maintaining this lift.
2. This lift is designed for indoor use only, and should not be installed in a pit or depression.
3. The floor on which the lift is to be installed **must be 4" (101mm) minimum thickness concrete, with a minimum compressive strength of 3000 psi (20 MPa) and reinforced steel bar.**
4. The lifts have specific electrical requirements as described in the Installation Instructions section of this manual.
5. This lift has a minimum ceiling height requirement as described in the Installation Instructions section of this manual.
6. Failure by the owner to provide the recommended shelter, mounting surface, electrical supply, and ceiling height could result in unsatisfactory lift performance, property damage, or personal injury.
7. Do not attempt to install this lift if you have never been trained on basic automotive lift installation procedures. Reference ANSI/ALI ALIOM requirements for installation and service of automotive lifts.
8. Never attempt to lift components without proper lifting tools such as forklift or cranes. Stay clear of any moving parts that can fall and cause injury. These instructions must be followed to insure proper installation and operation of your lift.
9. Danmar Equipment will assume no liability for loss or damage of any kind, expressed or implied resulting from improper installation or use of this product.
10. This lift is rated to 6,000-lbs lifting capacity. **NEVER EXCEED** rated lifting capacity of lift.
11. Qualified person must be consulted for seismic loads and other local or state requirements.

## DEFINITIONS OF HAZARD LEVELS

Identify the hazard levels used in this manual with the following definitions and signal words.



Hazards or unsafe practices which could result in severe personal injury or death.



Hazards or unsafe practices which may result in minor personal injury, product or property damage.



Hazards or unsafe practices which may result in minor personal injury, product or property damage.

Lubricate all plastic guide blocks, bearings, and shafts with grease prior to operating the lift. Lubricate all on a weekly basis. Motors and all electrical components are not sealed against the weather and moisture. Install this lift in a protected indoor location. Failure by the owner to provide the recommended shelter could result in unsatisfactory lift performance, property damage, personal injury, and may void the warranty.

**BE SAFE: YOUR NEW LIFT WAS DESIGNED AND BUILT WITH SAFETY IN MIND. HOWEVER, YOUR OVERALL SAFETY CAN BE INCREASED WITH PROPER TRAINING AND THOUGHTFUL OPERATION ON THE PART OF THE OPERATOR. DO NOT OPERATE OR REPAIR THIS EQUIPMENT WITHOUT READING THIS MANUAL AND THE IMPORTANT SAFETY INSTRUCTIONS SHOWN INSIDE. KEEP THIS OPERATION MANUAL NEAR THE LIFT AT ALL TIMES. MAKE SURE THAT ALL USERS READ AND UNDERSTAND THIS MANUAL.**

## **IMPORTANT SAFETY INSTRUCTIONS**

### **READ THESE SAFETY INSTRUCTIONS ENTIRELY**

Do not attempt to install this lift if you have never been trained on basic automotive lift installation procedures. Never attempt to lift components without proper lifting tools such as a forklift or crane. Stay clear of any moving parts that can fall and cause injury.



1. **READ ALL INSTRUCTIONS.**
2. **READ AND UNDERSTAND** all safety warning procedures before operating lift.
3. **KEEP AREA WELL LIGHTED.**
4. **WARNING! RISK OF EXPLOSION.** This equipment has internal arcing or sparking parts which should not be exposed to flammable vapors. This machine should not be located in a recessed area or below floor level.
5. **KEEP CONTROL HANDLES AND / OR BUTTONS** dry, clean and free from grease and oil.
6. **CARE MUST BE TAKEN** as burns can occur from touching hot parts on the hydraulic unit's electric motor.
7. **DO NOT** operate equipment with a damaged power cord or if the equipment has been dropped or damaged until it has been examined by a qualified service person.
8. **DO NOT** let the power cord come in contact with hot manifolds or moving fan blades.
9. **IF AN EXTENSION CORD IS NECESSARY**, a cord with a current rating equal to or more than that of the equipment should be used. Cords rated for less current than the equipment may overheat. Care should be taken to arrange the cord so that it will not be tripped over or pulled.
10. **ALWAYS UNPLUG EQUIPMENT FROM ELECTRICAL OUTLET WHEN NOT IN USE.** Never use the power cord to pull the power plug from the outlet. Grasp the plug and pull to disconnect.
11. **LET EQUIPMENT COOL COMPLETELY BEFORE PUTTING AWAY.** Loop power cord loosely around equipment when storing.
12. **TO REDUCE THE RISK OF FIRE**, do not operate equipment in the vicinity of open containers of flammable liquids (i.e., gasoline).
13. **ADEQUATE VENTILATION SHOULD BE PROVIDED** when working on operating internal combustion engines.
14. **KEEP HAIR, LOOSE CLOTHING, FINGERS, AND ALL PARTS OF THE BODY AWAY FROM MOVING PARTS.**
15. **TO REDUCE THE RISK OF ELECTRIC SHOCK**, do not use on wet surfaces or expose to rain.
16. **USE ONLY AS DESCRIBED IN THIS MANUAL.** Use only manufacturer's recommended attachments.
17. **DO NOT** raise vehicle on the lift until installation is completed as instructed in this manual.
18. **KEEP HANDS AND FEET CLEAR.** Remove hands and feet from any moving parts. Keep feet clear of lift when lowering. Avoid pinch points.
19. **KEEP WORK AREA CLEAN.** Cluttered work areas invite injuries.
20. **CONSIDER WORK AREA ENVIRONMENT.** Do not expose equipment to rain. **DO NOT** use in damp or wet locations. Keep area well lighted.



21. **ONLY TRAINED OPERATORS** should operate this lift. All non trained personnel should be kept away from work area. Never let non trained personnel come in contact with, or operate lift.
22. **USE LIFT CORRECTLY.** Use lift in the proper manner. Never use lifting adapters other than what is approved by the manufacturer.
23. **DO NOT** override self closing lift controls.
24. **REMAIN CLEAR** of lift when raising or lowering vehicle.
25. **CLEAR AREA** if vehicle is in danger of falling.
26. **ALWAYS ENSURE** that the safety locks are engaged before any attempt is made to work on or near vehicle.
27. **DRESS PROPERLY.** Non skid steel toe footwear is recommended when operating lift.
28. **GUARD AGAINST ELECTRIC SHOCK.** This lift must be grounded while in use to protect the operator from electric shock. Never connect the green power cord wire to a live terminal. This is for ground only.
29. **DANGER!** The power unit used on this lift contains high voltage. Disconnect power at the receptacle before performing any electrical repairs. Secure plug so that it cannot be accidentally plugged in during service.
30. **ALWAYS WEAR SAFETY GLASSES.** Everyday eyeglasses only have impact resistant lenses. They are not safety glasses.
31. **MAINTAIN WITH CARE.** Keep lift clean for better and safe performance. Follow manual for proper lubrication and maintenance instructions. Keep control handles and / or buttons dry, clean and free from grease and oil.
32. **STAY ALERT.** Watch what you are doing. Use common sense. Be aware!
33. **CHECK FOR DAMAGED PARTS.** Check for alignment of moving parts, breakage of parts or any condition that may affect its operation. Do not use lift if any component is broken or damaged.
34. **NEVER** remove safety related components from the lift. Do not use lift if safety related components are damaged or missing.

**NOTE:** If attachments, accessories, or configuration modifying components that are located in the load path, affect operation of the lift, affect the lift electrical listing or affect intended vehicle accommodation are used on this lift and, if they are not certified for use on this lift, then the certification of this lift shall become null and void. Contact Dannmar Equipment for information pertaining to certified attachments, accessories, or configuration modifying components.



When removing the lift from the shipping angles pay close attention as the posts can slide and can cause injury. Prior to removing the bolts make sure the posts are held securely by a fork lift or some other heavy lifting device.

**SHIPPING DAMAGE CLAIMS:** WHEN THIS EQUIPMENT IS SHIPPED, TITLE PASSES TO THE PURCHASER UPON RECEIPT FROM THE CARRIER. CONSEQUENTLY, CLAIMS FOR THE MATERIAL DAMAGED IN SHIPMENT MUST BE MADE BY THE PURCHASER AGAINST THE TRANSPORTATION COMPANY AT THE TIME SHIPMENT IS RECEIVED.

# SAVE THESE INSTRUCTIONS

## OWNER / EMPLOYER RESPONSIBILITIES

- Shall ensure that lift operators are qualified and that they are trained in the safe use and operation of the lift using the manufacturer's operating instructions and regional requirements.
- Shall establish procedures to periodically inspect the lift in accordance with the lift manufacturer's instructions and regional requirements. The Employer Shall ensure that lift inspectors are qualified and that they are adequately trained in the inspection of the lift.
- Shall establish procedures to periodically maintain the lift in accordance with the lift manufacturer's instructions and regional requirements, Inspection and Maintenance and The Employer Shall ensure that lift maintenance personnel are qualified and that they are adequately trained in the maintenance of the lift.
- Shall maintain the periodic inspection and maintenance records recommended by the manufacturer and regional requirements.
- Shall display the lift manufacturer's operating instructions; ALI/SM 93-1, ALI Lifting it Right safety manual; ALI/ST-10 ALI Safety Tips card; in a conspicuous location in the lift area convenient to the operator.
- Shall not modify the lift in any manner without the prior written consent of the manufacturer or regional requirements.
- Shall provide necessary lockout/ tagout means for energy sources per ANSI Z244.1-1982 (R1993), safety requirements for the lockout / tagout of energy sources, before beginning any lift repairs.

**INSTALLER / OPERATOR: PLEASE READ THE ENTIRE CONTENTS OF THIS MANUAL PRIOR TO INSTALLATION AND OPERATION. BY PROCEEDING WITH LIFT INSTALLATION AND OPERATION YOU AGREE THAT YOU FULLY UNDERSTAND AND COMPREHEND THE FULL CONTENTS OF THIS MANUAL. FORWARD THIS MANUAL TO ALL OPERATORS. FAILURE TO OPERATE THIS EQUIPMENT AS DIRECTED MAY CAUSE INJURY OR DEATH.**

- I have visually inspected the site where the lift is to be installed and verified the concrete to be in good condition and free of cracks or other defects. I understand that installing a lift on cracked or defective concrete could cause lift failure resulting in personal injury or death.
- I understand that a level floor is required for proper installation and level lifting.
- I understand that I am responsible if my floor is of questionable slope and that I will be responsible for all charges related to pouring a new level concrete slab if required and any charges.
- I understand that Danmar lifts are supplied with concrete fasteners meeting the criteria of the American National Standard "Automotive Lifts Safety Requirements for Construction, Testing, and Validation" ANSI/ALI ALCTV-2008, and that I will be responsible for all charges related to any special regional structural and/or seismic anchoring requirements specified by any other agencies and / or codes such as the Uniform Building Code (UBC) and / or International Building Code (IBC).
- I will assume full responsibility for the concrete floor and condition thereof, now or later, where the above equipment model(s) are to be installed. Failure to follow danger, warning, and caution instructions may lead to serious personal injury or death to operator or bystander or damage to property.
- I understand that Danmar lifts are designed to be installed in indoor locations only. Failure to follow installation instructions may lead to serious personal injury or death to operator or bystander or damage to property or lift.



Failure to follow danger, warning, and caution instructions may lead to serious personal injury or death to operator or bystander or damage to property.



Please read entire manual prior to installation. Do not operate this machine until you read and understand all the dangers, warnings and cautions in this manual. For additional copies or further information, contact:

MaxJax™  
5240 Willis Road  
Theodore, AL 36582  
877-453-0693

## **INSTALLER / OPERATOR PROTECTIVE EQUIPMENT**

Personal protective equipment helps makes installation and operation safer, however, it does not take the place of safe operating practices. Always wear durable work clothing during any installation and/or service activity. Shop aprons or shop coats may also be worn, however loose fitting clothing should be avoided. Tight fitting leather gloves are recommended to protect technician hands when handling parts. Sturdy leather work shoes with steel toes and oil resistant soles should be used by all service personnel to help prevent injury during typical installation and operation activities.

Eye protection is essential during installation and operation activities. Safety glasses with side shields, goggles, or face shields are acceptable. Back belts provide support during lifting activities and are also helpful in providing worker protection. Consideration should also be given to the use of hearing protection if service activity is performed in an enclosed area or if noise levels are high.



# PARTS INVENTORY

Be Sure to take complete inventory of parts prior to beginning installation.

## M6 ASSEMBLY

ITEM No.	PART NUMBER	DESCRIPTION	QTY	CHECK
1		POWER UNIT	1	
2	17404004	M6 INSTRUCTION MANUAL	1	
3	199825	ALI LIFTING POINT GUIDE (ALI/LP)	1	
4	199826	ALI SAFETY MANUAL (ALI-SM)	1	
5	199827	ALI SAFETY TIPS CARD (ALI-ST)	1	
6		SERIAL NUMBER TAG	1	
7	199865	DANNMAR M6 DECAL	4	
8	199888	ALI SAFETY STICKER SET, 2-POST LIFTS	1	
9	199889	ALI OWNER OPERATION STANDARD (ANSI/ALI ALOIM)	1	
10	199890	ALI CERTIFICATION STICKER (GOLD)	1	
11	17107036	ROUND LIFT PAD ADAPTER ASSEMBLY	4	
12	17108041	SHORT LIFT PAD EXTENSION	4	
13	17151009	POST ASSEMBLY	2	
14	17153014	ARM ASSEMBLY	4	
15	17154001	POWER UNIT STAND ASSEMBLY	1	
16	17156001	HYD. HOSE ASSEMBLY 10 x 4,520mm	2	
17	17156002	HYDRAULIC HOSE ASSEMBLY 10mm x 275mm	1	
18	17157026	LIFT HEAD PIN WELDMENT	4	
19	17200017	5-8in X 2 HEX HEAD BOLT	10	
20	17200028	M8 x 20 HEX HEAD BOLT	4	
21	17200067	M8 x 30 HEX HEAD BOLT	4	
22	17201010	M8 NYLON LOCK NUT	8	
23	17202012	5/8in FLAT WASHER	10	
24	17204030	LIFT HEAD PIN WELDMENT RELEASE PIN	4	
25	17206014	3-8in NPTF FEMALE x QUICK DISCONNECT FEMALE	2	
26	17206016	9-16in SAE ORB x 9-16in JIC, 90DEG ELBOW LONG WITH O-RING	1	
27	17206017	9-16in JIC X 3-8in NPTF, 90DEG ELBOW LONG	1	
28	17207015	POWER UNIT VIBRATION DAMPENER	1	
29	17207033	C-WASHER SHIM	20	
30	17207037	HYDRAULIC FLOW DIVIDER	1	
31	17207094	7-8in x 3.8125in DROP IN SLEEVE ANCHOR	10	
32	17401004	LABEL, SAFETY INSTRUCTIONS STICKER	1	
33	17401005	LABEL, SAFETY WARNING STICKER	1	
34	17401006	LABEL, CAPACITY WARNING STICKER	1	
35	17401007	LABEL, SAFETY LOCK STICKER	2	
36	17158151	CE ONLY, ARM FOOT GUARD, LEFT HAND	2	
37	17158152	CE ONLY ARM FOOT GUARD, RIGHT HAND	2	



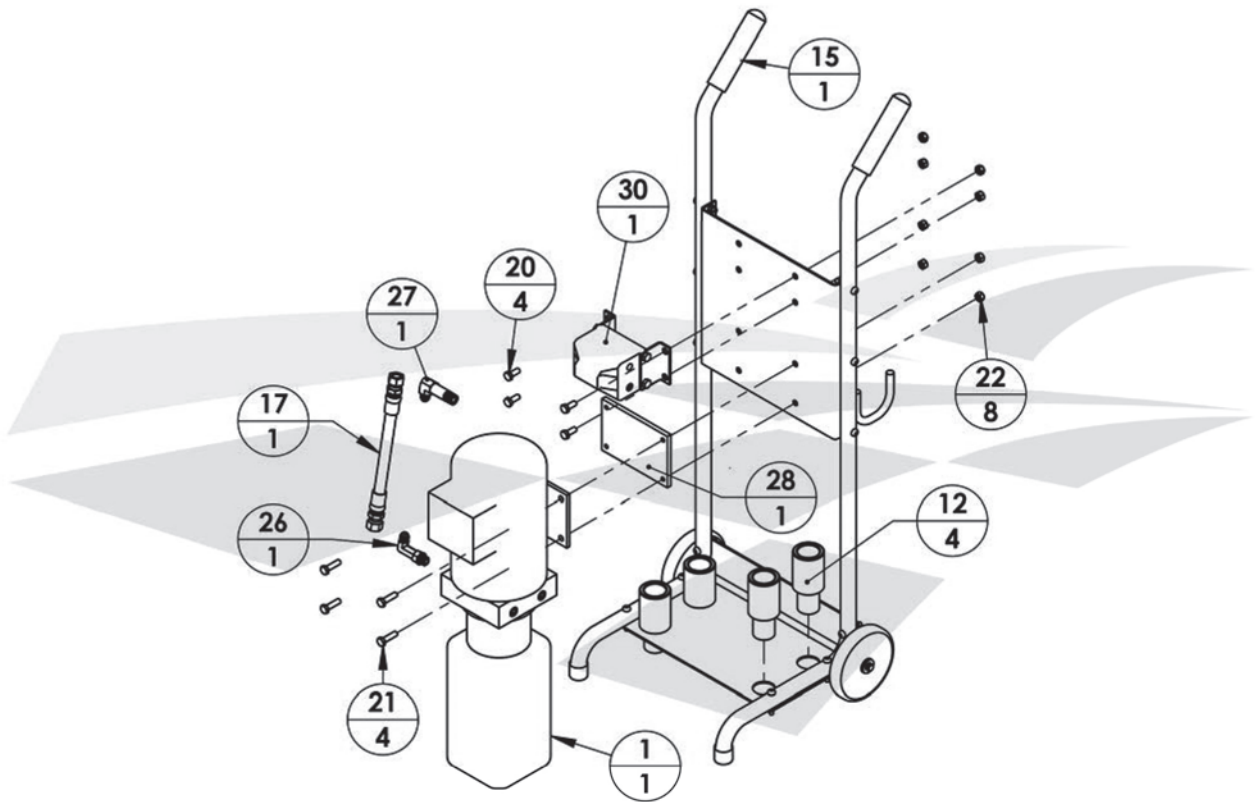
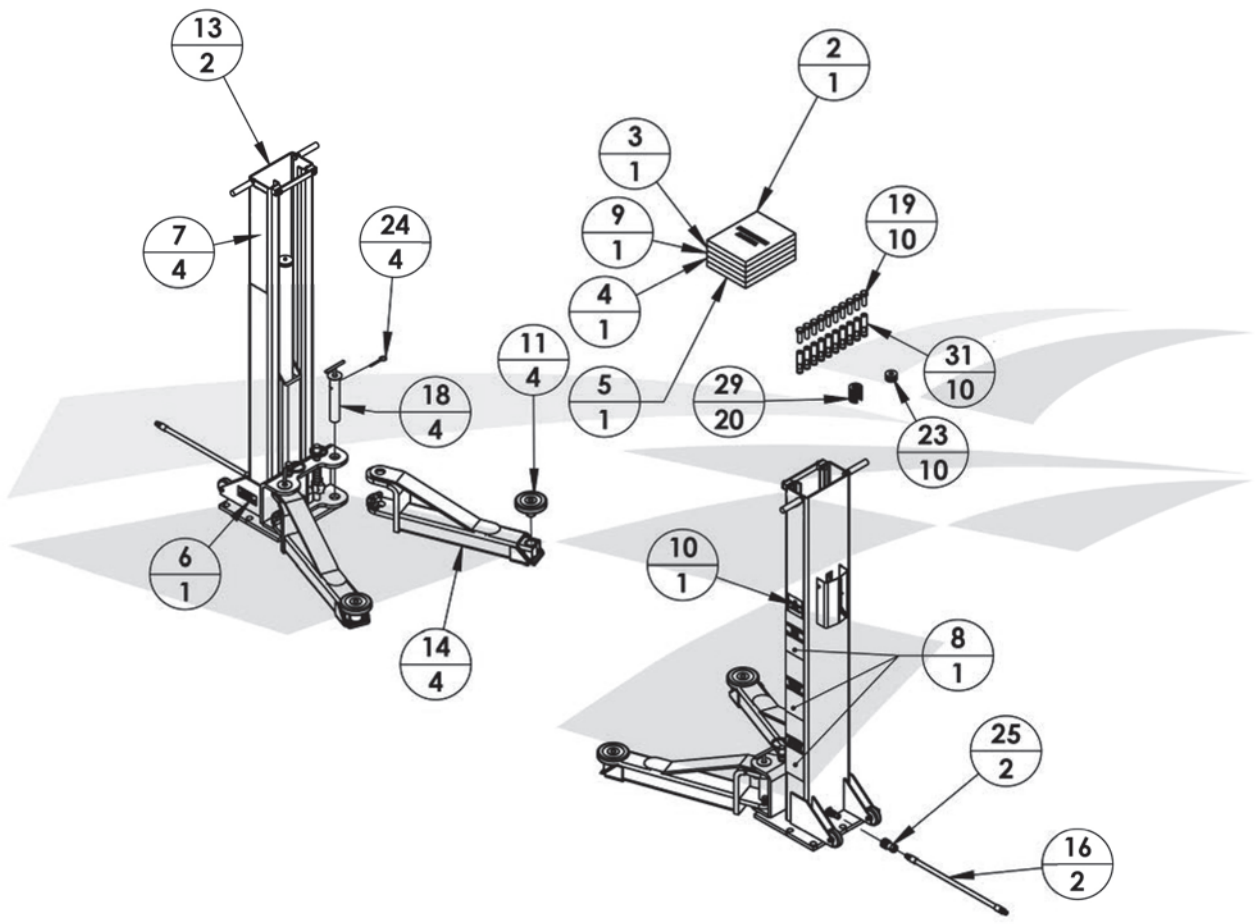

## PLASTIC PARTS BAG CONTENTS

PART NUMBER	DESCRIPTION	QTY	CHECK
17200006	M10 x 25 HEX HEAD BOLT	4	
17200011	M6 x 40 PAN HEAD MACHINE SCREW	12	
17200017	5-8in X 2 HEX HEAD BOLT	10	
17200028	M8 x 20 HEX HEAD BOLT	4	
17200029	M8 x 55 HEX HEAD BOLT	4	
17200067	M8 x 30 HEX HEAD BOLT	4	
17200075	M6 x 10 PAN HEAD MACHINE SCREW	4	
17201007	M6 NYLON LOCK NUT	12	
17201010	M8 NYLON LOCK NUT	12	
17202005	M12 FLAT WASHER	4	
17202012	5-8in FLAT WASHER	10	
17203017	TORSION SPRING, 2.5mm x 25.5mmOD x 17mm	4	
17204002	4mm HAIRPIN COTTER	2	
17204029	CLEVIS BOLT, 18mm x 85mm	2	
17204030	LIFT HEAD PIN WELDMENT RELEASE PIN	4	
17206014	3-8in NPTF FEMALE x QUICK DISCONNECT FEMALE	2	
17206015	3-8IN NPTF FEMALE x QUICK DISCONNECT MALE	2	
17206016	9-16in SAE ORB x 9-16in JIC, 90DEG ELBOW LONG WITH O-RING	1	
17206017	9-16in JIC X 3-8in NPTF, 90DEG ELBOW LONG	1	
17206018	3-8in NPTF NIPPLE, WITH HEX FLATS	2	
17206019	3-8in NPTF 45DEG STREET ELBOW	4	
17206020	1-4in NPTF MALE X 3-8in NPTF FEMALE, STRAIGHT EXPANDER	2	
17207033	C-WASHER SHIM	20	

## PARTS BOX CONTENTS

PART NUMBER	DESCRIPTION	QTY	CHECK
17107036	ROUND LIFT PAD ADAPTER ASSEMBLY	4	
17108041	SHORT LIFT PAD EXTENSION	4	
17156001	HYD. HOSE ASSEMBLY 10 x 4,520mm	2	
17156002	HYDRAULIC HOSE ASSEMBLY 10mm x 275mm	1	
17157001	HANDLE ASSEMBLY	4	
17157025	SAFETY RELEASE ASSEMBLY	2	
17157026	LIFT HEAD PIN WELDMENT	4	
17158007	HAND CART WHEEL	2	
17158010	WHEEL	4	
17158141	SAFETY COVER	2	
17207015	POWER UNIT VIBRATION DAMPENER	1	

## OPTIONAL ACCESSORIES

PART NUMBER	DESCRIPTION	QTY	CHECK
17157027	CE COMPLIANCE KIT	1	
17107022	FRAME CRADLE PAD ASSEMBLY	4	
17157007	MOTORCYCLE ADAPTER KIT	1	
100121	ANCHOR EPOXY KIT	1	
17108042	6" LONG LIFT PAD EXTENSION	4	

# INSTALLATION INSTRUCTIONS

## TOOLS REQUIRED

- Rotary Hammer Drill or Similar
- 7/8" (22mm) Masonry Bit
- Hammer
- 4 Foot Level (1.5 M)
- Open End Wrench Set: Metric
- Socket and Ratchet Set: Metric
- Hex Key / Metric Allen Wrench Set
- Large Crescent Wrench
- Large Phillips Screwdriver
- Chalk Line
- Medium Phillips Screwdriver
- Tape Measure: 25 Foot (7.5 M) Minimum

## IMPORTANT NOTICE

These instructions must be followed to ensure proper installation and operation of your lift. Failure to comply with these instructions can result in serious bodily harm and void product warranty. Manufacturer will assume no liability for loss or damage of any kind, expressed or implied resulting from improper installation or use of this product.

### STEP 1 SELECTING SITE

#### BEFORE INSTALLING YOUR NEW LIFT, CHECK THE FOLLOWING:

1. **LIFT LOCATION:** Always use architects plans when available. Check layout dimension against floor plan requirements making sure that adequate space is available.
2. **OVERHEAD OBSTRUCTIONS:** The area where the lift will be located should be free of overhead obstructions such as heaters, building supports, electrical lines etc.
3. **DEFECTIVE FLOOR:** Visually inspect the site where the lift is to be installed and check for cracked or defective concrete.



4. **OPERATING TEMPERATURE.** Operate lift only between temperatures of 41° - 104° F (5° - 40 ° C).
5. Lift is designed for **INDOOR INSTALLATION ONLY**.

### STEP 2 FLOOR REQUIREMENTS

This lift must be installed on a solid level concrete floor **minimum 4" (101mm) thick, compressive strength 3000 psi (20 MPa) with no more than 3 degrees of slope. FAILURE TO DO SO COULD CAUSE PERSONAL INJURY OR DEATH.**



- DO NOT** install this lift on any asphalt surface or any surface other than concrete.
- DO NOT** install this lift on expansion seams or on cracked or defective concrete.
- DO NOT** install this lift on a second / elevated floor without first consulting building architect.
- DO NOT** install this lift outdoors.



## STEP 3 INSTALLING HYDRAULIC CYLINDERS

1. Install the column wheels (P/N 17158010) using M8x55 hex head bolts (P/N 17200029) and M8 nylon lock nut (P/N 17201010) onto each column. Turn the columns over and lay them down with the open side up. Slide the lift head to the top of the post. Remove the cylinder from the post. **(See figure 1)**
2. Remove the 6mm allen bolt and install the cylinder fittings using teflon tape. Assemble all fittings together, including quick disconnect, preferably in a vice. Install fitting assembly into cylinder. **(See figure 2)**
3. Slide the fitting assembly through the access hole located on the backside of the columns. **(See figure 3)**
4. Slide the cylinders through the lift head tube. **(See figure 4)**
5. Slide lift head until it rests firmly on the baseplate. Stand the column up.
6. Install the column handles (P/N 17157001) with M10 x 25 hex head bolts (P/N 17200006) and tie bars (P/N 17157003) with M10x40mm hex bolts (P/N 17200010) and M10 nylon lock nuts (P/N 17201017). **(See figure 5)**

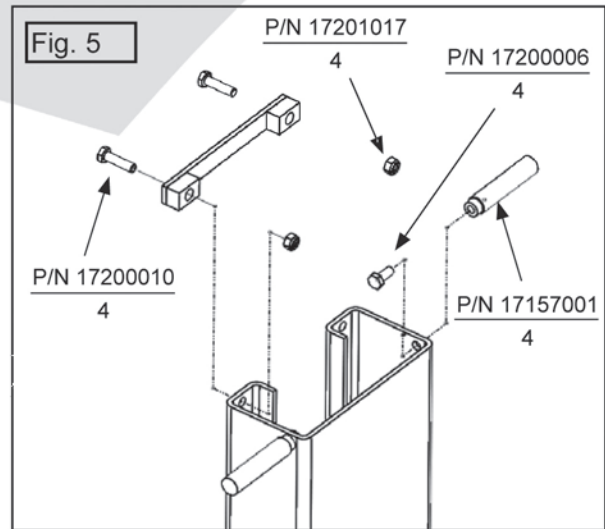
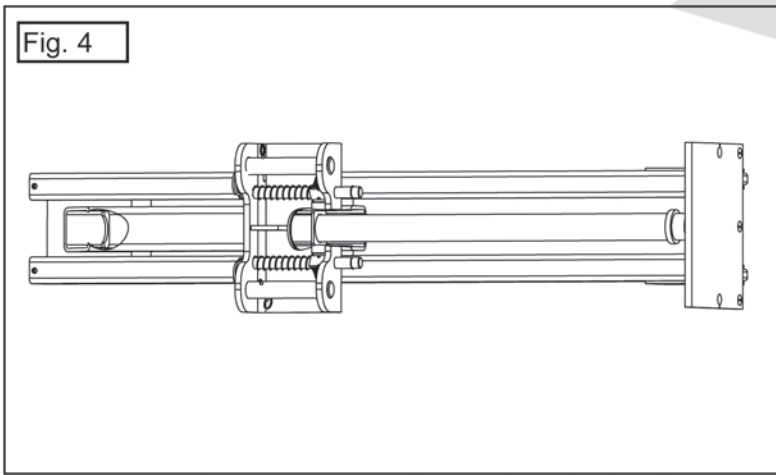
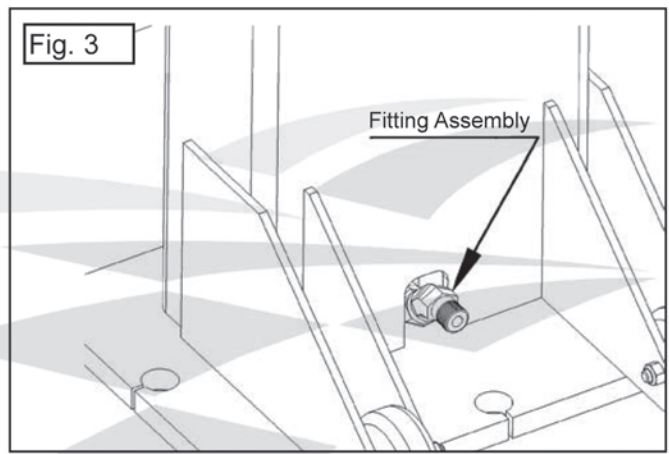
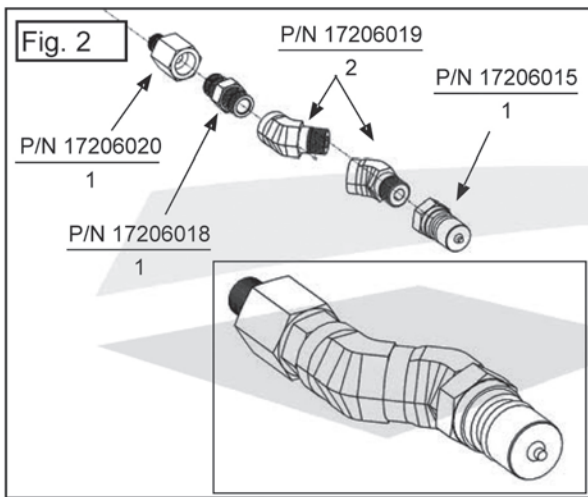
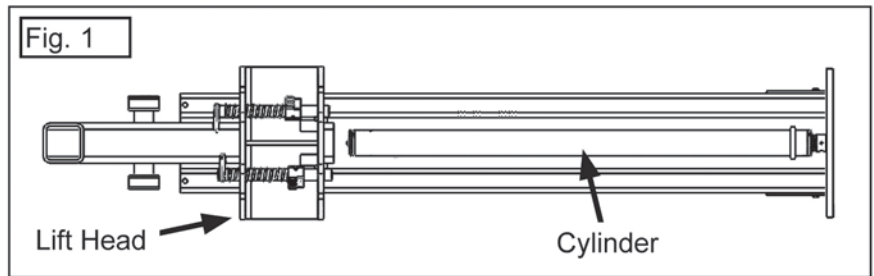

## STEP 4 MOUNTING HYDRAULIC POWER UNIT

Assemble cart as shown in the figures below:

1. After installing the cart wheels, attach the power unit and rubber power unit dampner pad to the power unit cart using the (4) m8x25mm hex bolts and nylon lock nuts. **(See figure 6)**
2. Attach the hydraulic flow divider to the power unit cart using the (4) m8x30mm hex bolts and nylon lock nuts supplied. **(See figure 7)**

**NOTE:**

Install flow divider so that when facing it from the front, the (2) plastic plugs are on the left and the (1) plastic plug is on the right.\*

3. Remove the plastic plug from the lower left port stamped "IN" on the flow divider. Install the long 90 degree 3/8 NPT fitting to 9/16 JIC. Use teflon tape on pipe thread side only. When tightening the fitting, tighten by hand first and then using a wrench turn approximately 3 turns past hand tight. **(See figure 8)**
4. Remove the plastic plug from the power unit. Install the long 90 degree 9/16 NPT with o-ring to 9/16 JIC fitting.
5. Attach the short power unit hose as shown. **DO NOT** use teflon tape on the JIC fittings. **(See figure 9)**

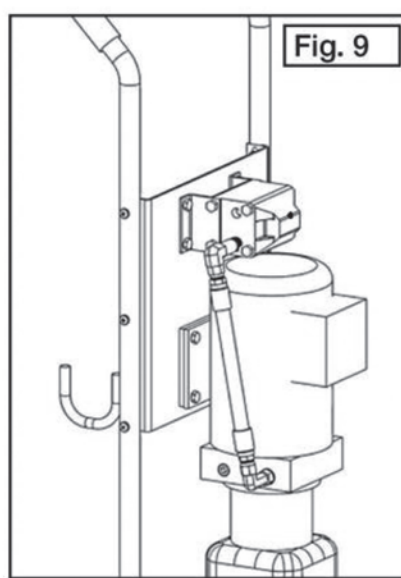
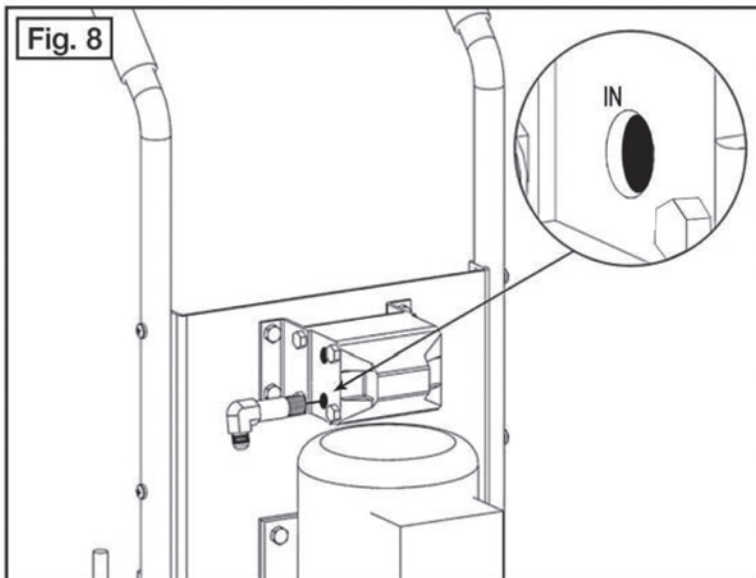
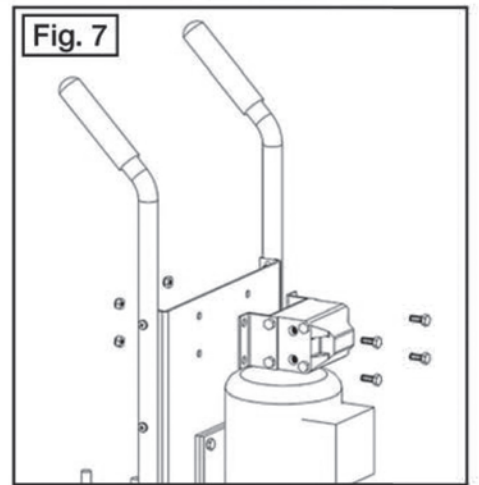
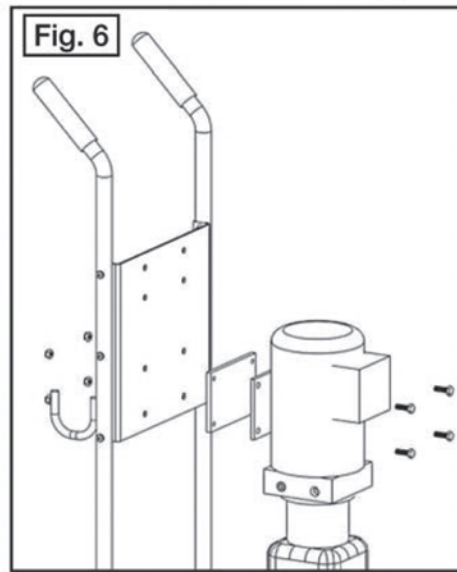
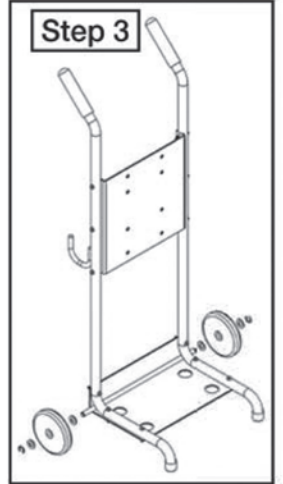
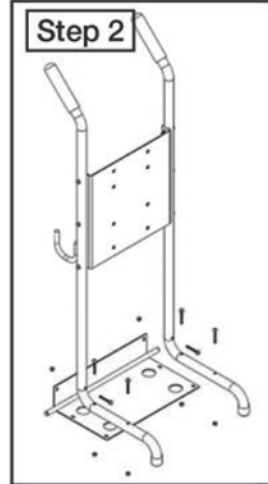
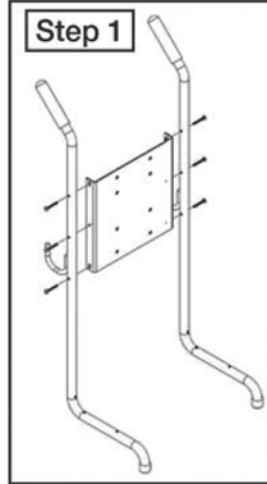

**NOTE:**

\*(Flow Divider)

Pay close attention to which side the bolts are on. When facing the flow divider, the bolt heads should be on the left side.

The lift will not work properly if the flow divider is installed upside down.

## STEP 5 SITE LAYOUT

1. Determine the location of where the lift will be installed based on the size of vehicles servicing. The dimensions shown below are rough guidelines. "Dry-fit" the vehicles intended to be serviced in the bay by referring to the ALI Lifting Point Guide for appropriate lift points before finalizing the column spacing.
2. Once a location is determined, use a carpenter's chalk line to layout a grid for the post locations. Keep all dimensions and squareness within 1/8" or malfunctioning of the lift can occur.
3. After the post locations are properly marked, use a chalk or crayon to make an outline of the columns on the floor at each location using the post base plates as a template.
4. Double check all dimensions and make sure that the layout is perfectly square.

**NOTE:**

Wide or narrow installation is possible. The lift can be installed at a width that suits the vehicles you will be raising. You may even choose to install additional anchors at varied column positions for adaptability to multiple vehicle configurations.

5. Recommended bay dimensions 20' deep and 14' wide.

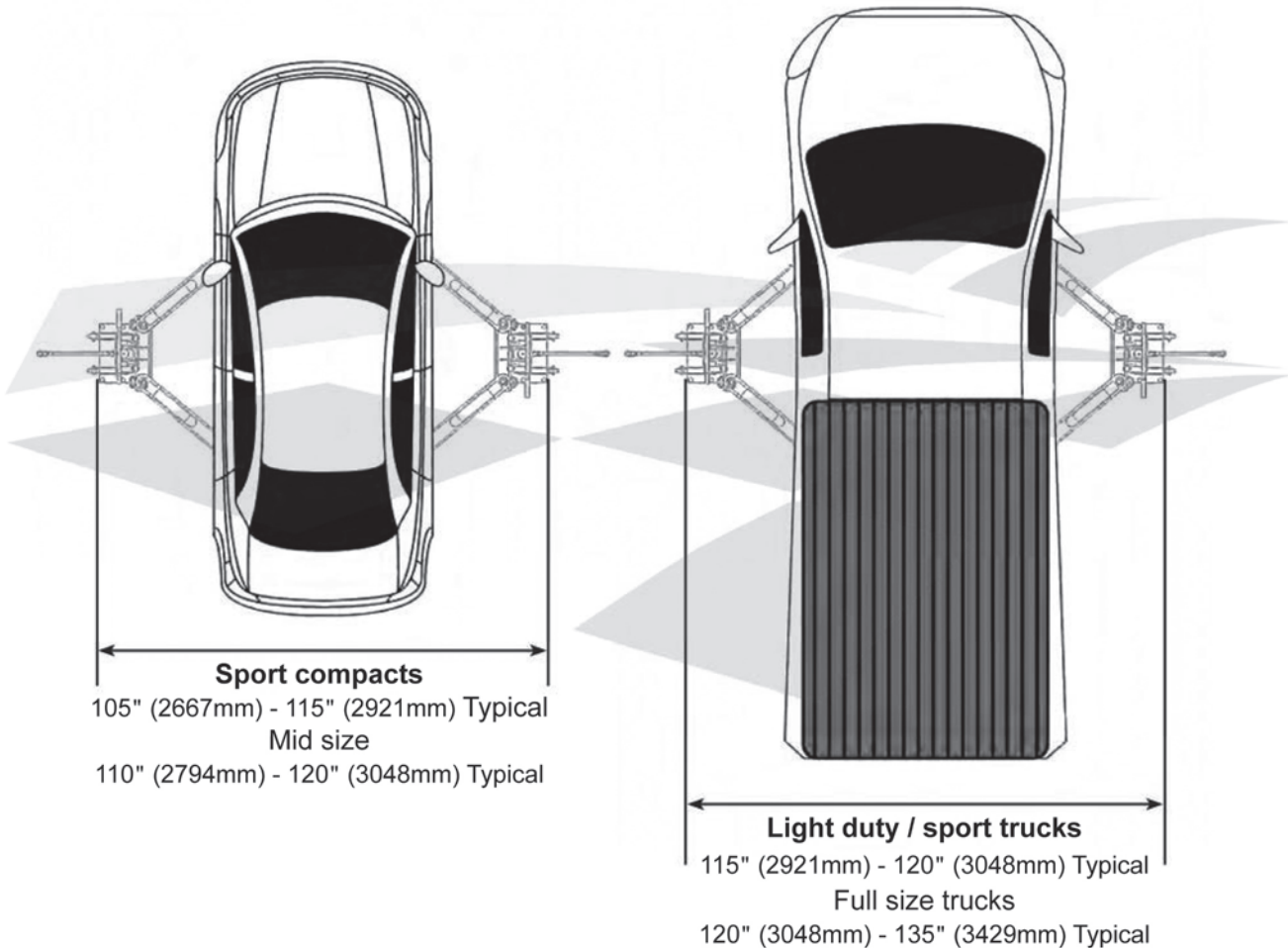

**Use the edge of the base plate to line up the posts along the chalk line.**

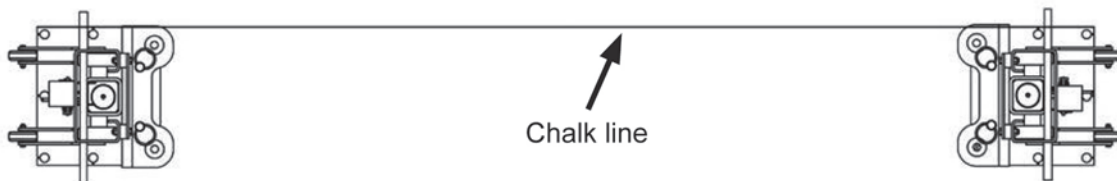



## STEP 6 INSTALLATION OF POWER DROP ANCHORS

1. Before proceeding, double check location and measurements, make certain that the base plates of each column are aligned with the chalk/crayon lines. The concrete must be minimum of 4" (101mm) thick with a minimum compressive strength of 3000 psi (20 MPa). FOLLOW PROCEDURE EXACTLY FOR PROPER FITTING AND ALIGNMENT OF ANCHORS. (See figure 10)

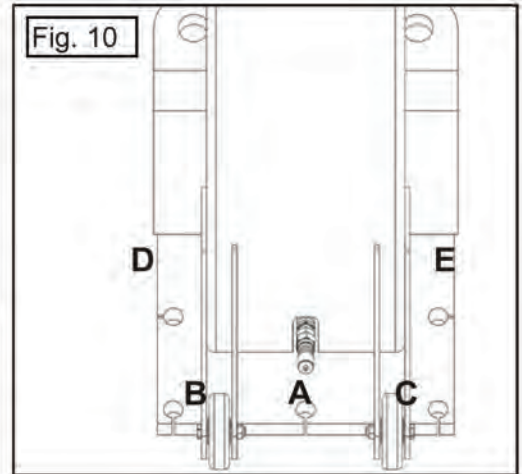

2. Use the squared-up base plate on the column as a guide. Using a rotary hammer drill with a 7/8" concrete bit, drill out each hole in the column to the minimum depth of 5". Do not ream the hole or allow the drill to wobble. When removing the bit be careful not to move the columns. Having someone secure or stand on the columns can be helpful. Repeat for all holes on both columns and move the columns out of the way. After drilling, thoroughly clean hole using a vacuum cleaner or compressed air and a nylon brush. (See figure 11)

3. Set the anchor embedment depth: Fully thread the 5/8" Setting Tool (sacrificial hex bolt) with assembled nut and washer into the anchor. Set the distance between the top of the anchor and the bottom of the nut/washer to 5/8". (See figure 12)

4. After setting the nut/spacer, place the anchor into the hole and hammer downward on the setting tool until the nut and washer makes contact with the surface of the concrete. (See figure 13)

5. To set the anchor tighten the nut while holding the bolt head (to assure the anchor does not spin in place) Do not use an impact wrench for this step. Tighten 3 full turns to reach an installation torque of 90 ft-lbs. (See figure 14)

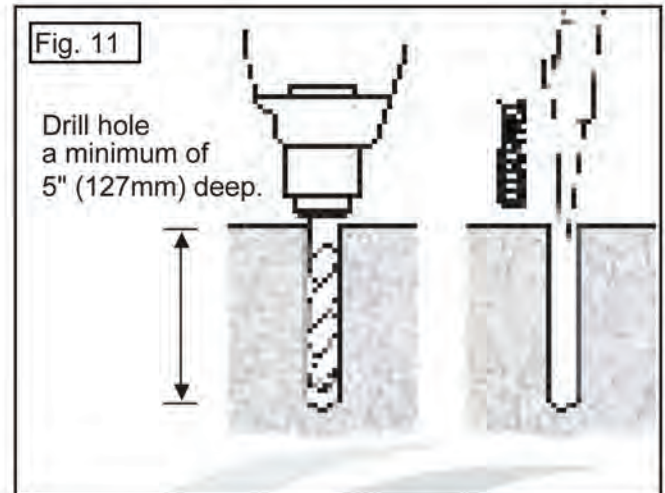

6. Once the anchor is set remove the cap screw and clear the anchor with compressed air to remove any concrete dust from the threads.

**NOTE:** Always wear safety glasses. Follow drill manufacturer's instructions. Use only solid carbide-tipped drill bits meeting ANSI B212.15 diameter standards.

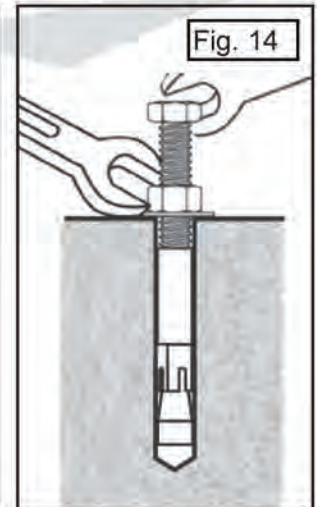
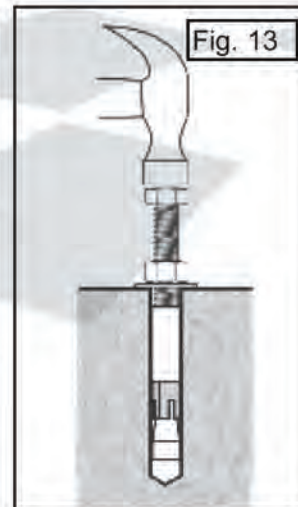
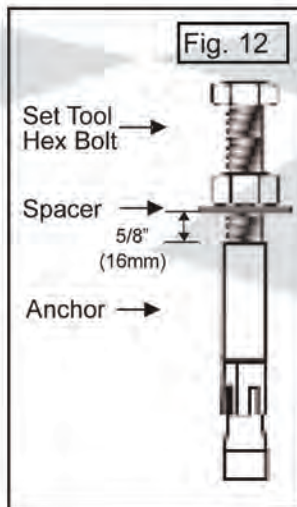

7. Install both columns with bolts and washers to anchors, check plumb and measurements as shown below.
8. If shimming is required, insert the shims as necessary under the base plate so that when the provided 5/8 x 2" anchor bolts are tightened, the columns will be plumb both side to side and front to rear. **(See figure 15)**
9. With the shims and anchor bolts in place, tighten all 5/8 x 2" anchor bolts tight to the base plate. **DO NOT USE AN IMPACT WRENCH** or the anchors could become compromised.

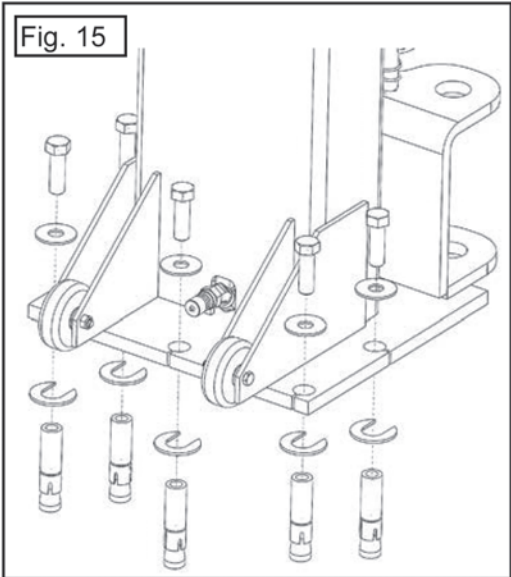

**NOTE:**

It will be helpful to mark on or otherwise note the location of shims used at each drop anchor to assist at time of re-installation.



Inspect all drop-in anchors for proper setting and or damage each time the lift is re-installed. Inspect the concrete for cracks defects and/or damage. Do not re-install the lift if any of the drop-in anchors are defective or the concrete is cracked or defective.



It may be necessary to shim the columns to ensure that the columns are plumb. The columns must be plumb and square or damage or injury may occur when using the lift. Do not exceed 1/8" total shim thickness.



**IMPORTANT LEVELING INSTRUCTIONS**

Before operating your lift, check to make sure both "A" and "B" measurements are equal. The lift arms must be level before operation. If your lift arms are not level, shim the columns as required.

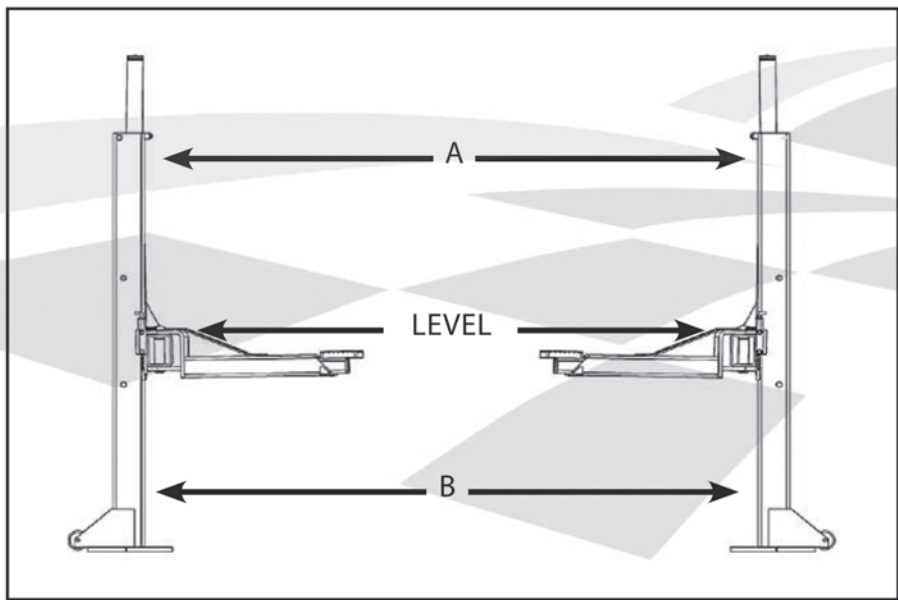



## STEP 7 CONNECTING HYDRAULIC LINES

- Using teflon tape, thread one end of the 3/8 NPT hose fittings into one of the top ports of the flow divider. Do this with both hoses. **(See figure 16)**

Using teflon tape, install the Female Quick Disconnect fittings (P/N 17206014) to the opposite end of each hose. **(See figure 17)**

Recheck all fitting connections to make sure they are properly tightened before proceeding.

Position the power unit stand at the front or rear of the vehicle.

Connect the Female Quick Disconnect fitting to the Male Quick Disconnect located at the bottom of each column. **(See figure 18)**

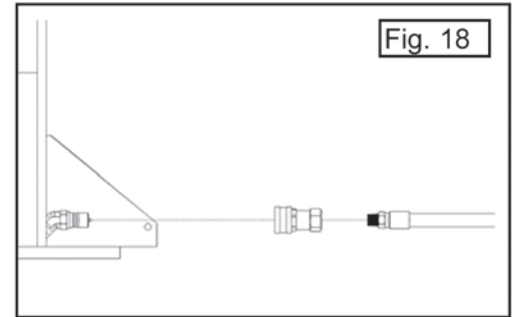
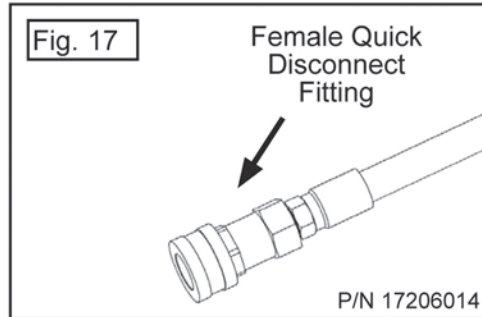
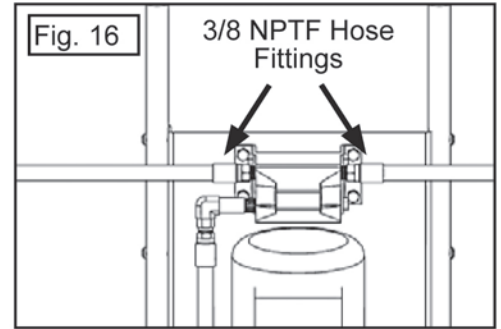

## STEP 8 HYDRAULIC POWER UNIT SET UP

- Fill the power unit reservoir with 7 quarts (6.6 L) of AW-32 hydraulic oil or Dexron III or VI automatic transmission fluid. Make sure the funnel used to fill the power unit is clean. After bleeding the cylinders, check the oil level to see if additional oil is needed to ensure the reservoir is full.
- The lift should be plugged into a dedicated circuit with a 20 amp circuit breaker. The standard power unit for this lift is:
  - US: 110V, 60Hz, single phase
  - CE: 230V, 50Hz, single phase

**⚠ DANGER**



ALL WIRING MUST BE PERFORMED BY A CERTIFIED ELECTRICIAN ONLY.



**RISK OF EXPLOSION**

This equipment has internal arcing or parts that may spark and should not be exposed to flammable vapors. The motor should not be located in a recessed area or below floor level.

- DO NOT run power unit without oil. Damage to pump can occur.
- The power unit must be kept dry. Damage to power unit caused by water or other liquids such as detergents, acid etc., is not covered under warranty.
- Improper electrical hookup can damage the motor and will not be covered under warranty.
- Motor can not run on 50hz without a physical change in the motor. (US - only)
- Use a separate breaker for each power unit.
- Protect each circuit with a time delay fuse or circuit breaker. (US-only)

## STEP 9 INSTALLING THE LIFT ARMS

1. Place the lift arm assembly on the lift heads. Install the lift head pins (P/N 17157026) into the lift head and through the holes in the arm assembly. Install the quick release pin into place on the arm pin. **(See figure 20 and 21)**

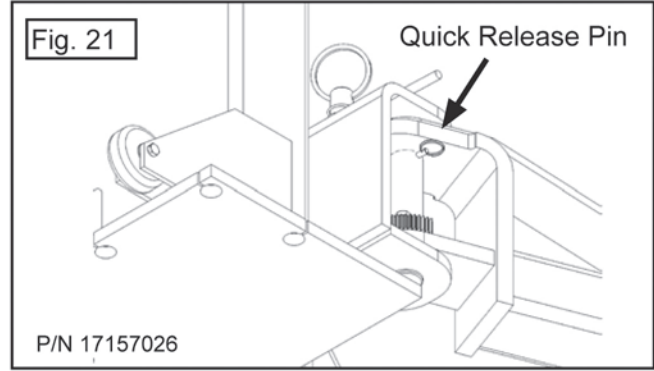
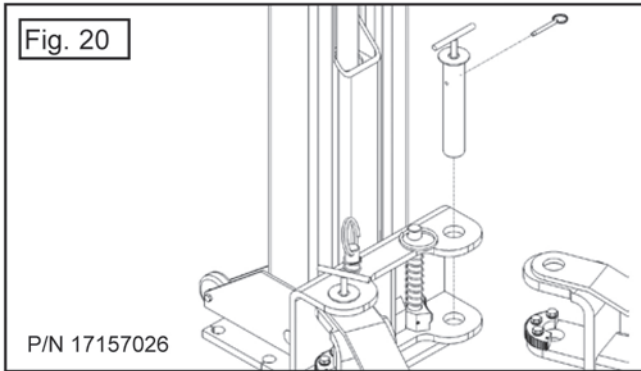

1. Raise the lift high enough so that the arm gear stops. Attempt to automatically engage the restraint gears on the arms.
2. Loosen the arm restraint gear ring bolts and adjust the arm restraint gears so that the teeth on the gear ring mesh smoothly with the teeth on the gears of the arm gear stop. **(See figure 22)**
3. Tighten the gear ring bolts
4. Verify the operation of the arm gear stops by pulling up on the key ring of the arm gear stops. Pivot the arms back and forth and test the operation of the arm gear stops in various positions. When releasing the arm gear stop, the pin should drop and the gears should engage. **(See figure 23)**
5. Ensure that the arms do not move when a force of at least 100 pounds is applied laterally to the fully extended arms. If they move, readjust the arm restraint gear ring and/or tighten the arm restraint gear ring bolts.
6. Adjust the gear ring on the arm as necessary to ensure smooth operation and solid engagement of all four arm restraint pins.

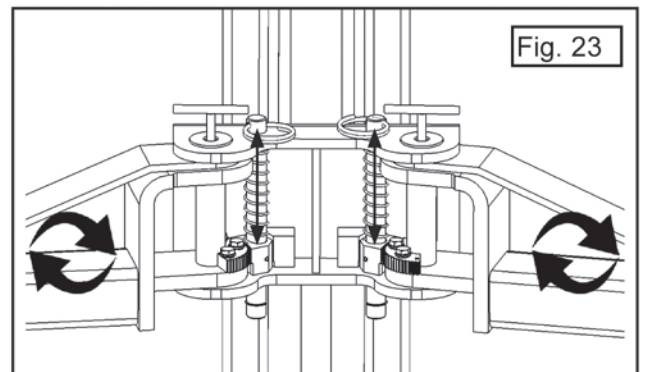
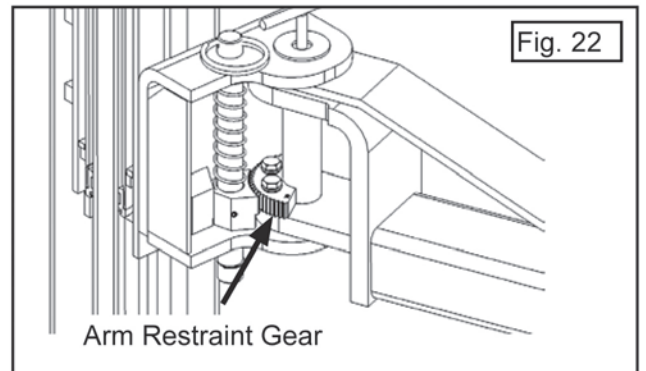

Each arm restraint assembly must be inspected and adjusted as needed before each and every time the lift is operated. Do not operate the lift if any of the four arm restraint systems are not functioning properly. Replace any broken components or components with broken teeth only with authorized or approved replacement parts.

### CE Users: Installing the Arm Foot Guards

1. Install the Foot Guards. They are directional (left/right sided) and will only fit properly on one side or the other. **(See figure 24)**

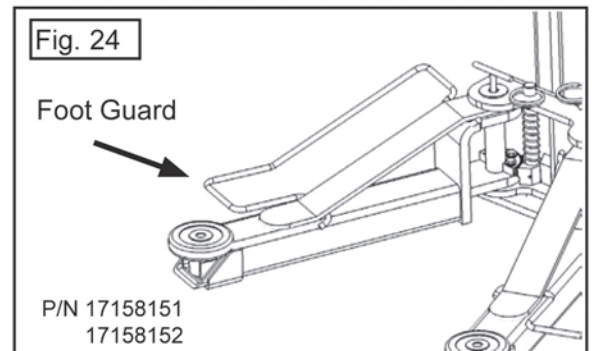



## STEP 10 INSTALLING THE SAFETY RELEASE LATCH

See page 30

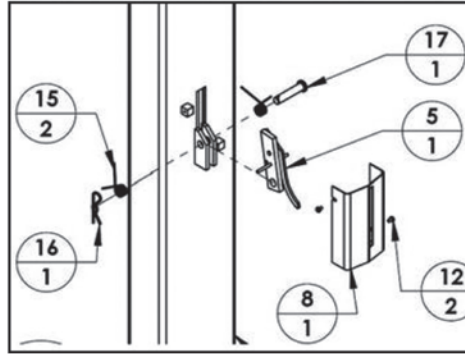

## STEP 11 BLEEDING THE CYLINDERS

1. With the lift in an elevated position, the hoses connected and the oil reservoir full, loosen the bleeder screws located at the top of each hydraulic cylinder using an allen wrench. Do not completely remove the bleeder screws. Watch and listen for trapped air escape the cylinders and fluid begins to weep from the screw area. Once steady fluid appears, re-tighten the bleeder screw and cleanup excess oil.

(See figure 19)



The lift will move down when bleeding, make sure all equipment, personnel, hands and feet are clear before starting bleeding procedure.

2. Repeat Bleeding procedure on opposite cylinder.
3. Press the lowering handle on the power unit until the lift lowers completely to the floor.



DO NOT use lift if an unlevel lifting condition occurs at the arm pad locations that is greater than 3.5" (89mm). If an unbalanced condition occurs, follow the bleeding instructions shown on this page or consult Technical Support. The lift must be re-leveled, shimmed and bled each time the lift is reinstalled. Failure to follow these instructions can result in serious injury or death.

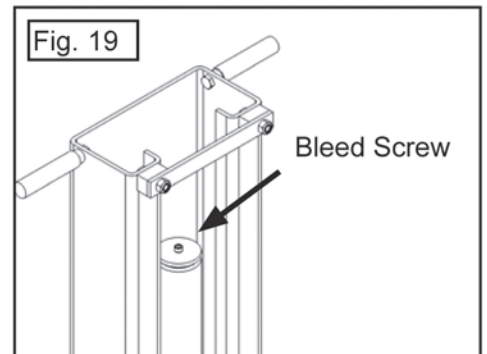

## STEP 12 LIFT START UP / FINAL ADJUSTMENTS

DURING THE START-UP PROCEDURE, OBSERVE ALL OPERATING COMPONENTS AND CHECK FOR PROPER INSTALLATION AND ADJUSTMENT. DO NOT ATTEMPT TO RAISE VEHICLE UNTIL A THOROUGH OPERATIONAL CHECK HAS BEEN COMPLETED.

1. Apply white lithium grease or equivalent to the inside of the columns where the slide blocks glide.
2. Test the power unit by pressing the push-button switch. Raise the lift a few inches and check all hose connections for leaks. If the motor gets hot or sounds peculiar, stop and check all electrical connections.
3. Raise the lift to it's maximum height off the floor until the lift head stops.
4. Lower the lift down below the first safety stop.

## POST INSTALLATION CHECK OFF

- |   |  |
|---|--|
| <input type="checkbox"/> Columns are properly leveled       | <input type="checkbox"/> Check for overhead obstructions                   |
| <input type="checkbox"/> Anchor bolts are tightened         | <input type="checkbox"/> Lift arms are level                               |
| <input type="checkbox"/> Electric power supply confirmed    | <input type="checkbox"/> Arm restraints properly adjusted                  |
| <input type="checkbox"/> Check for hydraulic leaks          | <input type="checkbox"/> All screws, bolts, and pins are secured           |
| <input type="checkbox"/> Check oil level                    | <input type="checkbox"/> Surrounding area is clear                         |
| <input type="checkbox"/> Lubrication of critical components | <input type="checkbox"/> Operation, maintenance and safety manuals on site |

## LIFT OPERATION SAFETY

- NEVER exceed rated capacity of 6,000-lbs.
- Tighten all anchor bolts prior to operation. If anchor bolts are loose, or any component of the lift is defective, do not use lift.
- DO NOT remove or disable arm restraints.
- DO NOT block, open or override self-closing lift controls; they are designed to return to the "Off" or Neutral position when released.
- ALWAYS inspect all quick connect/disconnect hose ends before any attempt is made to raise vehicle.
- ALWAYS be sure to have proper overhead clearance.
- ALWAYS load vehicle on lift carefully. Position the contact pads according to the vehicle manufacturer's recommended lift points. Raise lift until lift pads contact vehicle. Check pads for secure contact with the vehicle.

### NOTE:

Refer to ALI Quick Reference Guide for all point recommendations, dangers and safety data.

- ALWAYS remain clear of lift when raising or lowering vehicles.
- Do NOT use lift if an unlevel lifting condition occurs that is greater 3.5" (89 mm).
- DO NOT rock the vehicle or remove heavy components while on the lift that may alter weight distribution
- ALWAYS ensure Safety Locks are engaged before any attempt is made to work on or near vehicle.
- NEVER go under raised vehicle if Safety Locks are



VISUALLY CONFIRM THAT ALL SAFETY LOCKS ARE ENGAGED BEFORE ENTERING WORK AREA. SUSPENSION COMPONENTS USED ON THIS LIFT ARE INTENDED TO RAISE AND LOWER LIFT ONLY AND ARE NOT MEANT TO BE LOAD HOLDING DEVICES. REMAIN CLEAR OF ELEVATED LIFT UNLESS VISUAL CONFIRMATION IS MADE THAT SAFETY LOCKS ARE FULLY ENGAGED AND THE LIFT IS LOWERED ONTO THE SAFETY LOCKS, REFER TO OPERATION MANUAL FOR PROPER SAFETY LOCK PROCEDURES AND/OR FURTHER INSTRUCTIONS.

WHEN LOWERING THE LIFT PAY CAREFUL ATTENTION THAT ALL PERSONNEL AND OBJECTS ARE KEPT CLEAR. ALWAYS KEEP A VISUAL LINE OF SITE ON THE LIFT AT ALL TIMES. ALWAYS MAKE SURE THAT ALL LOCKS ARE DISENGAGED. IF ONE OF THE LOCKS INADVERTENTLY LOCKS UPON DESCENT THE VEHICLE MAY DISMOUNT CAUSING PERSONAL INJURY OR DEATH.

- ALWAYS remove tool trays, stands, etc. before lowering lift.
- ALWAYS release safety locks before attempting to lower lift.
- ALWAYS move the lift arms to provide an unobstructed exit before removing vehicle from lift area.

## STEP 13 LIFT OPERATION

**BE SURE TO READ ALL SAFETY TIPS PRIOR TO OPERATING LIFT. FAILURE TO DO SO MAY RESULT IN SERIOUS INJURY OR DEATH.**

### TO RAISE VEHICLE:

1. Center the vehicle between columns. Adjust vehicle front-to-back so the center of gravity falls in the middle of the columns.
2. Position lift contact pads at manufacturers recommended lifting points.
3. Before raising vehicle, be sure all personnel are clear of the lift and surrounding area. Pay careful attention to overhead clearances.
4. Raise lift by pressing raise button on power unit until contact pads make contact with the underside of vehicle. \*
5. Verify vehicle is secure and arm restraint locks are engaged on all 4 arms.
6. After the vehicle is raised to the desired height, press the lowering handle until the lift stops evenly on the safety locks. **(See figure 25)**
7. When raising the lift, always keep a visual line of site on the lift.

\*NOTE: Refer to ALI Reference Guide for all lift point recommendations and safety data.

### TO LOWER VEHICLE:

1. Before lowering vehicle, be sure all personnel are clear of the lift and surrounding area. Insure all tools and equipment have been cleared from under the lift.
2. Raise the lift off of the safety lock by pressing the raise button on the power unit. Make sure you raise the lift by at least one inch from the lock to allow adequate clearance.
3. Disengage the safety lock on each column by pulling up the release handle. **(See figure 26)**
4. Push the lowering handle on the power unit until the lift has descended completely and all 4 arm restraint gears are completely released.
5. When lowering the lift pay careful attention that all personnel and objects are kept clear. Always keep a visual line of site on the lift at all times.

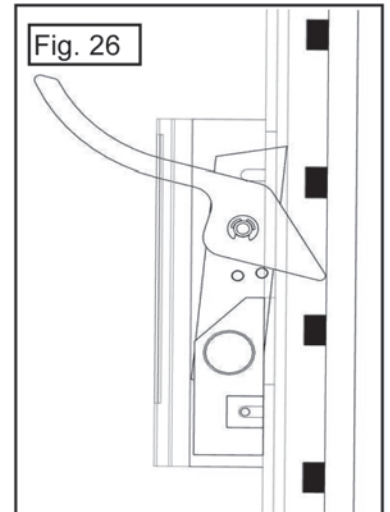
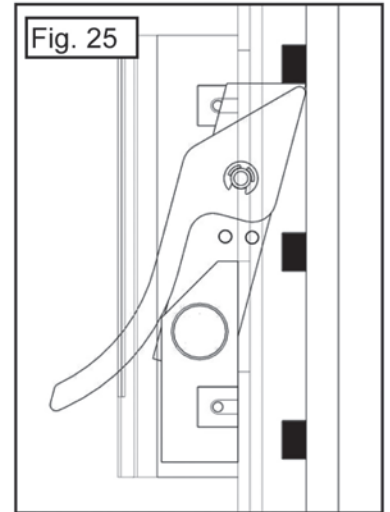

## WEEKLY MAINTENANCE

- Lubricate all moving parts with a white lithium grease.
- Check all connections, bolts and pins to insure proper mounting.

## MONTHLY MAINTENANCE

- Make a visual inspection of all moving parts and check for excessive signs of wear.
- Check condition of lift pads and adapters.
- Check condition of arm restraints. Adjust as necessary.
- Inspect all bolts, pins and anchor bolts.
- Replace all faulty parts before lift is put back into operation.

## STEP 14 LIFT REMOVAL

1. Depress the lowering valve on the power unit.
2. Ensure that the lift is lowered all the way to the ground and hydraulic pressure is relieved.
3. Disconnect the power unit from the power source and / or ensure that the power to the circuit is shut off to prevent accidental powering on of the lift while disassembling.
4. With a cloth in hand to collect weeping fluid, disconnect the cylinder hoses from the cylinder. Hoses can be coiled and stored on the power unit cart.

### WARNING

Before removing cylinder hoses, always ensure that the hydraulic pressure has been relieved from the system by depressing the lowering valve until the lift is fully lowered or the raised load is fully settled onto the safety lock blocks. Never connect or disconnect hoses with the lift in an elevated position.

### DANGER

Do not perform any maintenance or installation of any components without first ensuring that electrical power has been disconnected at the source or panel and cannot be re-energized until all maintenance and/or installation procedures are completed.

5. Be careful to clean up any spilled hydraulic fluid that may drip from the hose assemblies.
6. Remove the lift arm assemblies.
7. Loosen the anchor bolts. Be careful not to disturb the lift column until ready to move the column.
8. Move the column to your storage area. Secure with straps or other device to prevent any accidental tipping or movement of the columns during storage.

## STEP 15 RE-INSTALLATION

1. Clear installation area of debris, tools and equipment.
2. Blow out the mounting holes with compressed air or clean with a nylon brush.
3. Inspect the drop in anchors for proper setting and the concrete for defects and / or damage.
4. Line up the holes of the Base Plates with the anchors. Re-shim the lift as required to ensure the lift is installed level.
5. With the Shims and Anchor Bolts in place, tighten all Anchor Bolts tight to the base plate. **DO NOT USE AN IMPACT WRENCH FOR THIS PROCEDURE.**
6. Follow all procedures as outlined in Steps 8 - 12.

### WARNING

Inspect all drop in anchors for proper setting and or damage each time the lift is re-installed. Inspect the concrete for cracks defects and/or damage. Do not reinstall the lift if any of the drop in anchors are defective or the concrete is cracked or defective.

### DANGER

The lift must be re-leveled, shimmed and bled each time the lift is reinstalled. Failure to do so may result in injury or death.



## TROUBLESHOOTING GUIDE



**BE SAFE: DO NOT OPERATE OR REPAIR EQUIPMENT WITHOUT READING THIS MANUAL AND THE IMPORTANT SAFETY INSTRUCTIONS. KEEP THIS OPERATION MANUAL NEAR THE LIFT AT ALL TIMES. MAKE SURE THAT ALL USERS READ AND UNDERSTAND THIS MANUAL.**

### **LIFT WILL NOT RAISE (BUT MOTOR RUNS)**

#### **POSSIBLE CAUSE**

1. Air in oil, (1,2,6,10)
2. Cylinder / lift head binding, (7)
3. Cylinder leaks internally, (7)
4. Motor runs backward under pressure, (9)
5. Lowering valve leaks, (3,4,8,9)
6. Motor runs backwards, (5,11,9)
7. Pump damaged, (8,9)
8. Pump won't prime, (1,6,10,11,3,8,9)
9. Relief valve leaks, (8,9)
10. Voltage to motor incorrect, (7,14)

#### **REMEDY INSTRUCTIONS**

1. Check for proper oil level. The oil level should be up to the fill cap in the reservoir with the lift all the way down.
2. Bleed cylinders.
3. Flush lowering valve, hold lowering handle down and start unit for 15 seconds allowing possible contamination to break up.
4. Dirty oil, replace oil with clean hydraulic oil (AW-32 or Dexron III or VI ATF).
5. Check motor is wired correctly. Compare wiring of motor to electrical diagram on drawing.
6. Oil seal is damaged or cocked. Replace oil seal around pump shaft.
7. Consult lift manufacturer.
8. Replace with new part.
9. Return unit for repair.
10. Inlet screen clogged. Clean inlet screen or replace.
11. Check wall outlet voltages and wiring. Make sure unit and wall outlet are wired correctly.

## **MOTOR WILL NOT RUN**

### **POSSIBLE CAUSE**

1. Panel circuit breaker flipped, (5,2,1,3,4)
2. Motor burned out, (1,2,3,6,4)
3. Voltage to motor incorrect, (2,1)
4. CE USERS ONLY: Internal motor circuit breaker flipped (7)
5. CE USERS ONLY: Fuse protecting contractor has blown (8)

### **REMEDY INSTRUCTIONS**

1. Check for correct voltage. Compare supply voltage with voltage on motor name tag. Check that the wire is sized correctly. N.E.C. table 310-12 requires AWG 10 for 20 Amps. Check wall outlet voltage and wiring. Make sure unit and wall outlet is wired properly. Motor must run at: US - 110v. CE - 230v. Check regional requirements.
2. Check motor is wired correctly. Compare wiring of motor to electrical diagram on drawing.
3. Don't use extension cords. According to N.E.C. : " The size of the conductors should be such that the voltage drop would not exceed 3% to the farthest outlet for power". Check regional requirements.
4. Replace with new part.
5. Reset circuit breaker / fuse at panel.
6. Return unit for repair.
7. Reset circuit breaker inside motor junction box. Do not open junction box with power unit plugged in/energized.
8. Replace fuse accessible from outside motor junction box with a 1A or less rated equivalent. Do not replace with power unit plugged in/energized.

## **LIFT LOWERS SLOWLY OR NOT AT ALL**

### **POSSIBLE CAUSE**

1. Flow divider is installed upside down, (1)
2. Cylinders / lift head binding, (2)
3. Lowering valve clogged, (6,5,3,4)
4. Safety mechanism engaged or binding, (7,2,4,3)

### **REMEDY INSTRUCTIONS**

1. Ensure the flow divider is installed correctly. Refer to page 13.
2. Consult lift manufacturer.
3. Replace with new part.
4. Return for repair.
5. Check oil. Use clean hydraulic oil (AW-32 or Dexron III or VI automatic transmission fluid only). If fluid is contaminated, replace with clean fluid and clean entire system.
6. Clean lowering valve. Wash lowering valve in solvent and blow out with air.
7. Verify that the safety mechanism is disengaged prior to lowering the lift.

## **WILL NOT RAISE ONLY UNDER LOADED CONDITION**

### **POSSIBLE CAUSE**

1. Air in oil, (4,1,2,3)
2. Cylinder / lift head binding, (5)
3. Cylinder leaks internally, (5)
4. Lift overloaded, (6,5)
5. Lowering valve leaks, (7,1,8,5,9)
6. Motor runs backwards, (10,12,9)
7. Pump damaged, (5,9)
8. Pump won't prime, (1,2,3,4,11,5,9)
9. Relief valve leaks, (8,5,9)
10. Voltage to motor incorrect, (10,12,5)

### **REMEDY INSTRUCTIONS**

1. Check oil level. The oil level should be in the proper range on the dipstick with the lift all the way down.
2. Check / tighten inlet fittings and hose connections.
3. Oil seal is damaged or cocked. Replace oil seal around pump shaft.
4. Bleed cylinders.
5. Consult lift manufacturer.
6. Check vehicle weight. Compare weight of vehicle to weight limit of the lift.
7. Flush lowering valve. Hold lowering handle down and start unit allowing it to run for 15 seconds.
8. Replace with new part.
9. Return unit for repair.
10. Check if motor is wired correctly. Compare wiring of motor to electrical diagram on power unit drawing.
11. Inlet screen clogged. Clean inlet screen or replace.
12. Check wall outlet voltage and wiring. Make sure unit and wall outlet is wired properly.

## **LOAD IS UNEVEN**

### **POSSIBLE CAUSE**

1. Air in oil (3,1,2)
2. Cylinder / lift head binding (4)
3. Cylinder leaks internally (4)
4. Vehicle is not centered properly or level (5)
5. Flow divider is faulty (4)

### **REMEDY INSTRUCTIONS**

1. Check oil level. The oil level should be up to the fill cap in the reservoir with the lift all the way down.
2. Check / tighten inlet fittings and hose connections.
3. Bleed cylinders.
4. Consult lift manufacturer.
5. Make sure the vehicle is centered between columns. Ensure the swing arms are positioned with the center of gravity midway between pads. Position lift contact pads at manufacturer's recommended lifting points.



## GENERAL DISCLAIMER

In addition to all claims listed on each of the individual WARRANTY pages, the following GENERAL DISCLAIMERS apply.

1. The purchaser of any MaxJax product (Buyer) assumes the risk of verifying all materials or resources used or relied on. In no event will MaxJax be liable to the Buyer or to anyone else for any decision made or action taken in reliance on information obtained from any MaxJax website or from any MaxJax dealer, or third-party website, or any online or published catalog.
2. MaxJax has exclusive title and ownership rights including all intellectual property right throughout the world for all material and content contained on any MaxJax website or from any MaxJax online or published catalog.
3. MaxJax warrants that all products shown on any MaxJax website or in any online or published catalog conform to MaxJax published specifications only and are free from defects in material or workmanship as more fully set forth in the Warranty for the specific product.
4. MaxJax websites may contain hypertext or other links to websites not owned or controlled by MaxJax. Links to other computer systems or websites are not supervised nor regularly reviewed by MaxJax. | MaxJax specifically disavows legal responsibility for any information, personal opinions, guidance, advice or instruction that a Buyer receives from others or other websites.
5. Materials, design, specifications, images and other content from any MaxJax website, or any other MaxJax affiliate or dealer website, or any MaxJax online or published catalog are subject to change. MaxJax takes no responsibility for improper use or any results thereof. MaxJax reserves the right to make changes to all published warranties, website content, or published content without incurring any obligation to notify the Buyer or public that changes were made.
6. MaxJax products are provided and sold as is without any express or implied warranties including warranties of merchantability or fitness for particular purpose, other than the published written limited Warranty for the specific product or as required by law.
7. MaxJax makes no promises, guarantees or assurances that our products meet any state, county, federal or international mandated permit, license, code, standard, certification, or any other mandate other than what is listed or shown on MaxJax website(s), or any MaxJax online or published catalog. Not all MaxJax lift products meet the standards as prescribed by ANSI/ALI ALCTV-(current edition) or ANSI/UL 201. Consult [www.autolift.org](http://www.autolift.org) for a complete list of lift models that meet ANSI/ALI ALCTV-(current edition) or ANSI/UL 201, or contact MaxJax via [contact@maxjaxusa.com](mailto:contact@maxjaxusa.com). Buyer assumes full responsibility for any state, county, federal or international mandated permit, license, code, standard, certification, or any other mandate required related to the installation and/or operation at any MaxJax product. MaxJax will not be responsible for any charges, fines, liens, or other levies imposed on the Buyer related to any special or regional structural, seismic or any other building code and/or codes such as the Uniform Building Code (UBC), International Building Code (IBC) or any other state, county, federal or international mandated permit, license, code, standard, certification, or other mandate, law, rule, regulation or directive by any other agency, government, administrations, or corporations whether state, county, federal, or international mandated.
8. In no event will MaxJax be liable for any special, incidental, or consequential damages based on breach of warrant, breach of contract, negligence, strict tort, or any other legal theory. Damages that MaxJax will not be responsible for include, but are not limited to: loss of profits; loss of savings or revenue; loss of use of the product or any associated equipment; cost of capital; cost of any substitute equipment, facilities, or services; downtime; the claims of third parties, including customers; and injury to property. This limitation does not apply to damages caused by breach of the warranty of title and against infringements or to claims for personal injury.

9. Unless modified in a writing signed by both parties, it is understood that MaxJax published Warranties and MaxJax Terms and conditions of Sale are to be the complete and exclusive agreement (Agreement) between the parties superseding all oral or written prior agreements and all other communications between the parties relating to the subject matter of said Agreement, including statements made by sales persons. No employee of MaxJax or any other party is authorized to make any warranty in addition to those made in the Agreement. The buyer is warned, therefore, to check all Warranties and review in full detail the Terms and Conditions of Sale carefully to see that it correctly reflects those terms that are important to the Buyer.

10. The Agreement allocates the risks of product failure between MaxJax and the buyer. This allocation is recognized by both parties and is reflected in the price of the goods. Buyer acknowledges that they have read and fully understand the Agreement, and are bound by its terms. Some States do not allow limitations on how long an implied warranty lasts, so the above limitation may not apply to some Buyers. This warranty gives the Buyer specific legal rights. The Buyer may have other rights also which vary from State to State.

11. ANY ACTION FOR BREACH OF WARRANTY MUST BE COMMENCED WITHIN 60-DAYS FOLLOWING EXPIRATION DATE OF ANY WARRANTY PROVISION OR TERM.

## Standard Warranty

Duration: From the date of purchase by the original Purchaser or 12 months from the date of shipment or whichever comes first.

- Three-Years (36-Months) Warranty on equipment structure\*
- One-Year (12-Month) Warranty on operating components
- One-Year (12-Month) Free Shipping\*\* on ground-freight charges related to warranty performance

## Limited Warranty

1. Who gives this warranty (Warrantor): MaxJax, 1645 Lemonwood Dr., Santa Paula, CA 93060
2. Who receives this warranty (Purchaser): The original Purchaser (other than for purpose of resale)
3. What products are covered by this warranty: MaxJax portable lift system
4. What is covered under this warranty: manufacturer defects due to material and/or workmanship with the exceptions noted below.
5. What is not covered under this warranty:
  - a. The cost of labor to make repairs or replacements
  - b. Any failure that results from Purchaser's abuse, neglect or failure to operate, maintain or service product in accordance with instructions provided in the owner's manual(s) supplied
  - c. Any damage caused by using equipment beyond rated capacity and/or capability
  - d. Items or service normally required to maintain the product, i.e. lubricants, oil, etc.
  - e. Items considered general wear parts such as rubber or plastic pads/protectors, worn casters/wheels, etc. unless wear or failure is a direct result of manufacturer defect due to material and/or workmanship
  - f. Any component damaged in shipment or any failure caused by installing or operating equipment under conditions not in accordance with installation and operation guidelines or damaged by contact with tools or surroundings
  - g. Any component failure caused by rain, excessive humidity, corrosive environments or other contaminants
  - h. Rusted components due to improper maintenance or corrosive environments
  - i. Cosmetic defects that do not interfere with product functionality
  - j. Damage due to incorrect voltage or improper wiring
  - k. Any incidental, indirect, or consequential loss, damage, or expense that may result from any defect, failure, or malfunction of a MaxJax product
  - l. All electrical components are guaranteed for one year (12 months) against defects in workmanship and/or materials when the lift is installed and used according to specifications
6. Responsibilities of Warrantor under this warranty: Repair or replace with either new or reconditioned unit at Warrantor's option, component and/or unit which is defective, has malfunctioned and/or failed to conform within duration of the warranty period.
7. Responsibilities of Purchaser under this warranty:
  - a. Provide dated proof of purchase and maintenance records
  - b. In some cases, components may be required to be shipped to the nearest MaxJax Authorized Service Center. Freight costs, after 12 months, must be borne by the Purchaser.
  - c. Use reasonable care in the operation and maintenance of the products as described in the owner's manual(s).
8. When Warrantor will perform repair or replacement under this warranty: Repair or replacement will be scheduled and serviced according to the normal work flow at the servicing location, and depending on the availability of replacement parts.

\*Equipment structure is defined as any non-moving permanently affixed frame or main body, or sub-structures that are non-moving and permanently affixed or attached to any main equipment structure or frame.

\*\*Free-shipping applies to direct shipping points within the 48 continental United States. Rural area shipping surcharge may apply for remote addresses.

## Limitation of Liability

MaxJax shall have no obligation pursuant to this Warranty with respect to products which in our sole judgment have been altered damaged, misused, abused, badly worn, lost or improperly maintained. This Warranty is null and void if the customer or any other person other than an authorized representative of MaxJax has made any attempt to service or modify the tool prior to its return to MaxJax under this Warranty. In no event will either party be liable for any damage caused by the other party's failure to fulfill its responsibilities under these terms and conditions. In no event will either party be liable for any lost profits, lost savings, incidental damage, or other economic consequential damages MaxJax products are provided and sold as is without any express or implied warranties including warranties of merchantability or fitness for particular purpose. No warranties, expressed or implied, will apply after this period. MaxJax may modify these terms and conditions at any time by either providing the customer with written notice or posting such revised terms on [www.MaxJax.com](http://www.MaxJax.com). Such revised terms shall be effective thirty days from the date of such written notice or posting.





# SAFETY LATCH INSTALLATION

1. Insert the safety latch release on to the safety weldment pin.
2. Slide the retaining ring on to safety weldment pin.

ITEM NO.	PART NUMBER	DESCRIPTION	QTY.
1	17157024	SAFETY WELDMENT	1
2	17158131	SAFETY LATCH RELEASE	1
3	17207090	RETAINING RING, EXTERNAL, E-STYLE, 0.375in SHAFT	1

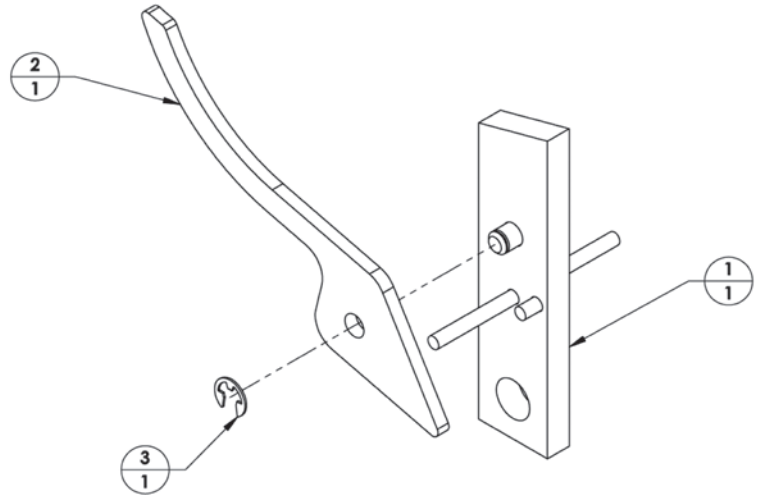

3. Slide the safety release assembly on to the safety release plate on the post.
4. Insert the clevis bolt thru the torsion spring.
5. Insert the clevis bolt thru both the safety weldment and the release plate.
6. Insert the 2nd torsion spring on to the clevis bolt.
7. Attach the cotter pin to the bolt.
8. Attach the safety cover with 2 M6 screws.

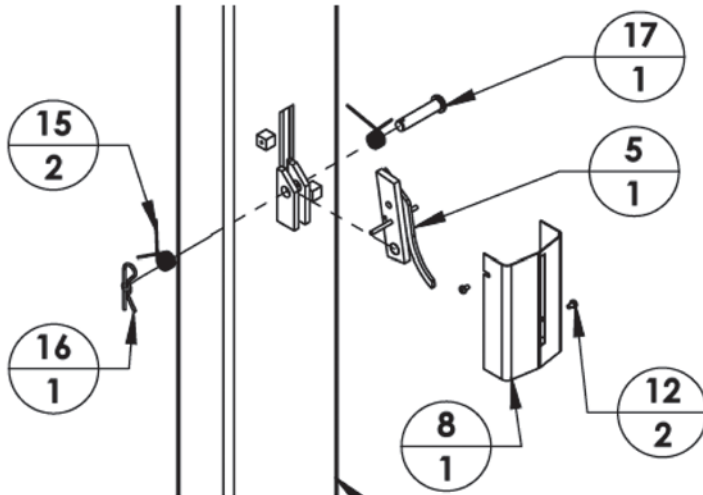

ITEM NO.	PART NUMBER	DESCRIPTION	QTY.
1	17151001	POST WELDMENT	1
2	17152010	LIFT HEAD ASSEMBLY	1
3	17157001	HANDLE ASSEMBLY	2
4	17157003	POST STRAP WELDMENT	1
5	17157025	SAFETY RELEASE ASSEMBLY	1
6	17158009	SLIDE BLOCK	4
7	17158010	WHEEL	2
8	17158141	SAFETY COVER	1
9	17200006	M10 x 25 HEX HEAD BOLT	2
10	17200010	M10 x 40 HEX HEAD BOLT	2
11	17200029	M8 x 55 HEX HEAD BOLT	2
12	17200075	M6 x 10 PAN HEAD MACHINE SCREW	2
13	17201010	M8 NYLON LOCK NUT	2
14	17201017	M10 NYLON LOCK NUT	2
15	17203017	TORSION SPRING, 2.5mm x 25.5mmOD x 17mm	2
16	17204002	4mm HAIRPIN COTTER	1
17	17204029	CLEVIS BOLT, 18mm x 85mm	1

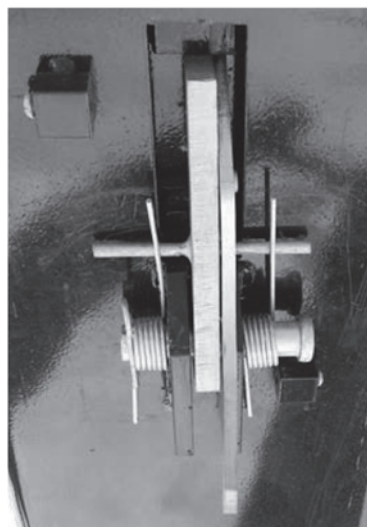

# OVERALL LIFT SPECIFICATIONS

## SPECIFICATIONS

Lifting Capacity*	6,000 Lbs. / 2727 Kg
*Max Capacity / Front Axle	3,000 Lbs. / 1364 Kg.
*Max Capacity / Rear Axle	3,000 Lbs. / 1364 Kg.
Max Load Per Arm:	1,500 Lbs. / 682 Kg.
A - Height Overall: (*)	89" / 2261 mm.
B- Height of Column:	64" / 1626 mm.
C - Typical Width (Outside of Base Plate):	105" - 135" / 2667 mm. - 3175 mm.
D - Arm Reach (Min.):	28.6" / 727 mm.
E - Arm Reach (Max.):	42.75" / 1085 mm.
F - Min. Pad Height:	3.5" / 89 mm.
G - Max Lift Height (Pad Only):	45" / 1143 mm.
H - Max Lift Height (With 3" Adapter):	48" / 1219 mm.
Locking positions:	7
Motor (**)	110V(US)-220V(CE) / 50-60 Hz. 1Ph.
Time of full Rise:	30-Seconds
Individual Column Weight :	315 Lbs. / 143 Kg.

\* To top of cylinder when extended to max rise.  
 \*\* Special Voltages Available Upon Request.  
 The design, material and specifications are subject to change without notice.

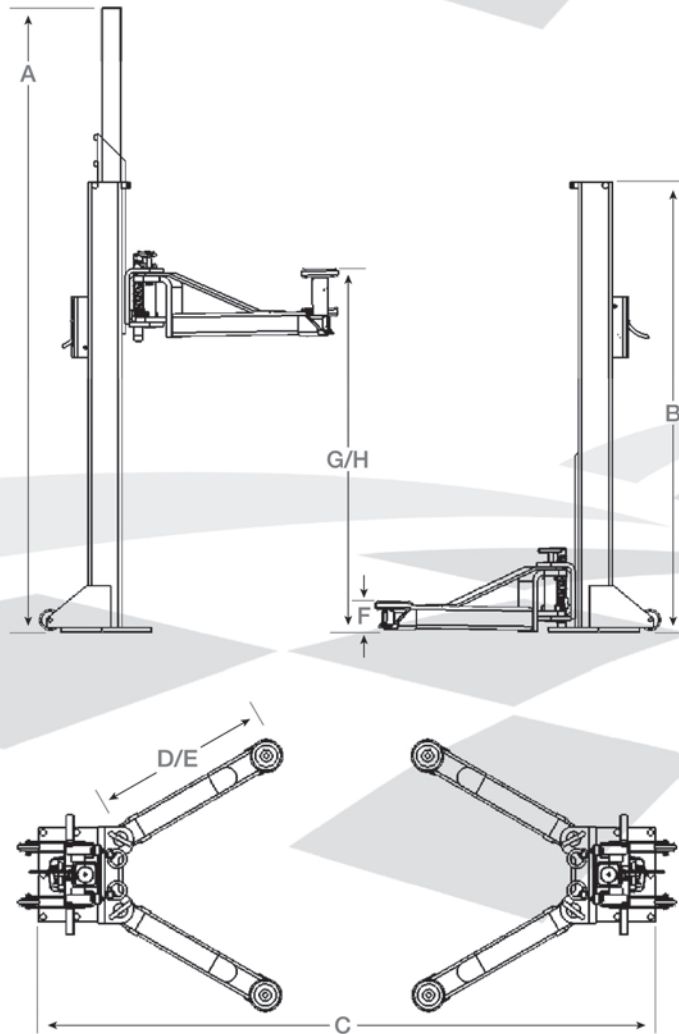



## **FOR PARTS OR SERVICE CONTACT:**

MaxJax™  
5240 Willis Road  
Theodore, AL 36582  
877-453-0693

ALTHOUGH EVERY EFFORT HAS BEEN TAKEN TO ENSURE COMPLETE AND ACCURATE INSTRUCTIONS HAVE BEEN INCLUDED IN THIS MANUAL, POSSIBLE PRODUCT UPDATES, REVISIONS AND OR CHANGES MAY HAVE OCCURRED SINCE THE PRINTING OF THIS MANUAL. DANNMAR EQUIPMENT RESERVES THE RIGHT TO CHANGE SPECIFICATIONS WITHOUT INCURRING ANY OBLIGATION FOR EQUIPMENT PREVIOUSLY OR SUBSEQUENTLY SOLD. DANNMAR EQUIPMENT IS ALSO NOT RESPONSIBLE FOR TYPOGRAPHICAL ERRORS.