

MOBI-EVS™ EV Battery and Powertrain Lifting System Setup and Operation Manual

Manual 5900376 — Revision A1 — March 2024

Model:

- EVS4500
- EVS3000

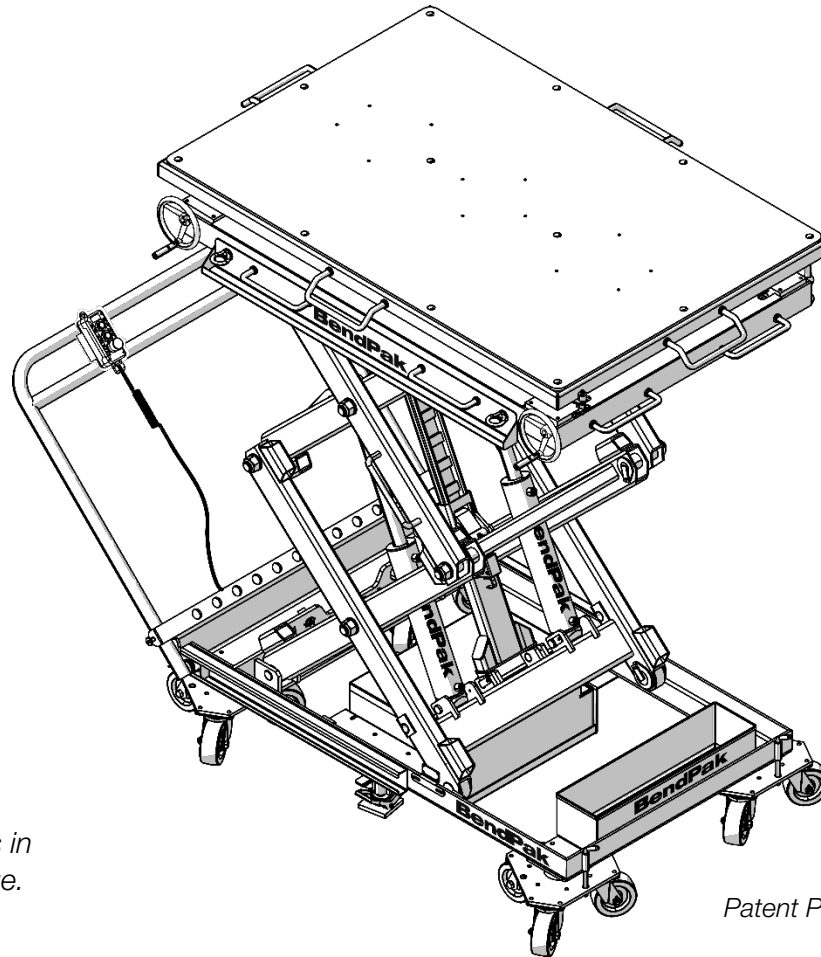

*Original instructions in
the English language.*

Patent Pending

Designed and engineered by BendPak Inc. in Southern California, USA. Made in China.

DANGER

IMPORTANT Safety Instructions, save these instructions! Read the *entire contents* of this manual *before* using this product. Failure to follow the instructions and safety precautions in this manual can result in severe injury or death. Make sure all other operators also read this manual. Keep the manual near the product for future reference. *By proceeding with setup and operation, you agree that you fully understand the contents of this manual and assume full responsibility for product use.*

Manual. MOBI-EVS™ Battery and Powertrain Lifting System, Models EVS4500 and EVS3000, *Setup and Operation Manual*, Manual Part Number 5900376, Revision A1, released March 2024.

Copyright. Copyright © 2024 by BendPak Inc. All rights reserved. You may make copies of this document if you agree that: you will give full attribution to BendPak Inc., you will not make changes to the content, you do not gain any rights to this content, and you will not use the copies for commercial purposes.

Trademarks. BendPak and the BendPak logo are registered trademarks of BendPak Inc. All other company, product, and service names are used for identification only. All trademarks and registered trademarks mentioned in this manual are the property of their respective owners. You can always find the latest version of the **manual for your product at the BendPak website**.

Limitations. Every effort has been made to ensure complete and accurate instructions are included in this manual. However, product updates, revisions, and/or changes may have occurred since this manual was published. BendPak reserves the right to change any information in this manual without incurring any obligation for equipment previously or subsequently sold. BendPak is not responsible for typographical errors in this manual. The latest version of this manual is available at www.bendpak.com or by scanning the QR code.



Warranty. The BendPak warranty is more than a commitment to you: it is also a commitment to the value of your new product. Contact your nearest BendPak dealer for full warranty details.

Safety. Your product was designed and manufactured with safety in mind. However, your safety also depends on proper training and thoughtful operation. Do not install, operate, maintain, or repair the unit without reading and understanding this manual and the labels on the unit; **do not use your Lift unless you can do so safely!**

Owner Responsibility. To ensure operator safety and maintain your product properly, it is the responsibility of the product owner to read and follow these instructions:

- Follow all setup, operation, and maintenance instructions.
- Make sure product setup and use conforms to all applicable local, state, and federal codes, rules, and regulations, such as state and federal OSHA regulations and electrical codes.
- Read and follow all safety instructions. Keep them readily available for operators.
- Make sure all operators are properly trained, know how to safely operate the unit, and are properly supervised.
- Do not operate the product until you are certain all parts are in place and operating correctly.
- Carefully inspect the product on a regular basis and perform all maintenance as specified.
- Service and maintain the unit only with approved replacement parts.
- Keep all instructions permanently with the product and verify all labels are clean and visible.
- BendPak makes no promises, guarantees or assurances that our products meet any state, county, federal or international mandated permit, license, code, standard, certification, or any other mandate other than what is listed or shown on BendPak website(s), or any BendPak or Ranger online or published catalog. Not all BendPak Lift models meet the standards as prescribed by ANSI/ALI ALCTV-(current edition) or ANSI/UL 201. Consult <https://www.autolift.org/> for a complete list of Lift models that meet ANSI/ALI ALCTV or ANSI/UL 201 or contact BendPak via contact@bendpak.com. Buyer assumes full responsibility for any state, county, federal or international mandated permit, license, code, standard, certification, or any other mandate required related to the installation and/or operation of any BendPak or Ranger product. BENDPAK will not be responsible for any charges, fines, liens, or other levies imposed on the Buyer related to any special or regional structural, seismic or any other building code and/or codes such as the Uniform Building Code (UBC), International Building Code (IBC), or any other state, county, federal or international mandated permit, license, code, standard, certification, or other mandate, law, rule, regulation or directive by any other agency, government, administrations, or corporations whether state, county, federal, or international mandated.
- **Only use this Lift if it can be used safely!**

Unit Information. Enter the Model Number, Serial Number, and the Date Code from the label on your unit. This information is required for part or warranty issues.

Model: _____

Serial: _____

Date of Manufacture: _____

BP BendPak Santa Paula, CA USA www.bendpak.com		
MODEL NUMBER		
DESCRIPTION		
LIFT CAPACITY		
DATE CODE	SERIAL NUMBER	
UPC		
DANGER! Disconnect Power Before Servicing		
CE EAC		
MADE IN CHINA	WARRANTY VOID IF DATA PLATE IS REMOVED	PN 5905150

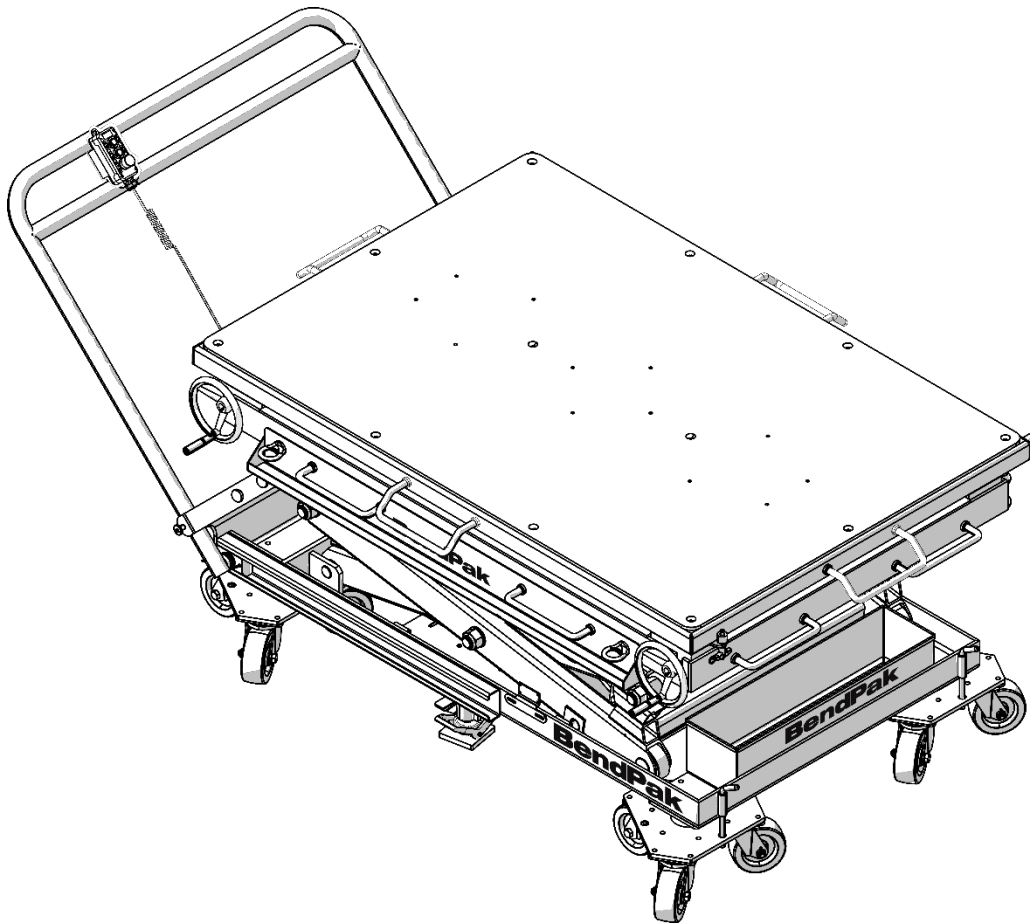

Table of Contents

Introduction	4	Accessories	40
Shipping Information	4	Maintenance	42
Safety Considerations	5	Troubleshooting	49
Components	12	Wiring Diagram	51
Specifications	13	Labels	52
Setup	15	Parts Drawings	55
Operation	26	Maintenance Logs	67

Introduction

This manual describes the setup and operation of two MOBI-EVS™ models:

- **EVS4500** — Battery-Powered, Full Rise Mobile Scissor Lift Table for safely servicing Electric Vehicle Battery Packs and Powertrains weighing up to 4,500 lbs. (2,041 kg).
- **EVS3000** — Battery-Powered, Full Rise Mobile Scissor Lift Table for safely servicing Electric Vehicle Battery Packs and Powertrains weighing up to 3,000 lbs. (1,361 kg).

The EVS3000 and EVS4500 meets or exceeds the standards as prescribed by ASME PASE (Current Edition) (Safety Standard for Portable Automotive Service Equipment)

This manual is mandatory reading for all users of the MOBI-EVS™ EV Lift Table System, including anyone who sets up, operates, maintains, or repairs them. Keep this manual on or near the equipment so that anyone who uses or services the Lift can access it.

Technical support and service is available from your dealer, on the Web at [bendpak.com/support](https://www.bendpak.com/support), by email at support@bendpak.com, or by phone at **(800) 253-2363**, option 7, then 4.

Scan this QR Code for up-to-date information and videos on the MOBI-EVS Lifting System.

Online chat is also available at <https://www.bendpak.com/> click the chat icon.



Shipping Information

Your equipment was carefully checked before shipping. Nevertheless, you should thoroughly inspect the shipment **before** you sign to acknowledge that you received it.

When you sign the bill of lading, it tells the carrier that the items on the invoice were received in good condition. **Do not sign the bill of lading until after you have inspected the shipment.** If any of the items listed on the bill of lading are missing or damaged, do not accept the shipment until the carrier makes a notation on the bill of lading that lists the missing and/or damaged goods.

If you discover missing or damaged goods **after** you receive the shipment and have signed the bill of lading, notify the carrier at once and request the carrier to make an inspection. If the carrier will not make an inspection, prepare a signed statement to the effect that you have notified the carrier (on a specific date), and that the carrier has failed to comply with your request.

It is difficult to collect for loss or damage after you have given the carrier a signed bill of lading. If this happens to you, file a claim with the carrier promptly. Support your claim with copies of the bill of lading, freight bill, invoice, and photographs. Our willingness to assist in helping you process your claim does not make us responsible for collection of claims or replacement of lost or damaged materials.

Following are the symbols used in this manual:

Safety Considerations

Important Safety Instructions, save these instructions!

Read this entire manual carefully before installing or using the product. Do not install or operate the product until you are familiar with all operating instructions and warnings. Do not allow anyone else to operate it until they are familiar with all operating instructions and warnings.

 **WARNING** **California Proposition 65 Warning.** This product can expose you to chemicals including styrene and vinyl chloride which are on the list of over 900 chemicals identified by the State of California to cause cancer, birth defects or reproductive harm. **ALWAYS** use this product in accordance with BendPak's instructions. For more information go to www.P65Warnings.ca.gov.

Symbols

Following are the symbols used in this manual:

 **DANGER** Calls attention to an immediate hazard that **will** result in death or severe injury.

 **WARNING** Calls attention to a hazard or unsafe practice that **could** result in death or severe personal injury.

 **CAUTION** Calls attention to a hazard or unsafe practice that could result in minor personal injury, product damage, or property damage.

NOTICE Calls attention to a situation that, if not avoided, could result in product or property damage.

**Tip**

Calls attention to information that can help you use your product better.

Liability Information

BendPak Inc. assumes **no** liability for damages resulting from:

- Use of the equipment for purposes other than those described in this manual.
- Modifications to the equipment without prior, written permission from BendPak.
- Injury or death caused by modifying, disabling, overriding, or removing safety features.
- Damage to the equipment from external influences.
- Incorrect operation of the equipment.

IMPORTANT SAFETY INSTRUCTIONS!

1. Read all instructions.
2. The MOBI-EVS Lift is a Battery Powered Full-Rise Scissor Lift designed for servicing Electric Vehicle Battery Packs and Powertrains. **Use it only for its intended purpose.** Improper use of this Lift could cause severe injury or death.
3. Always keep the load's Center of Gravity centered and balanced on the Lift's top deck.
4. The Lift is intended for **indoor use only, outdoor use is prohibited.**
5. The product should be operated by authorized and properly trained personnel only. Training includes reading and understanding the safety, operation, and maintenance sections of this manual and warning labels on the Lift.
6. You **must** always wear OSHA-approved (Publication 3151) Personal Protective Equipment when installing, using, maintaining, or repairing the Lift. Leather gloves, steel-toed work boots, ANSI-approved back belts, and hearing protection **are mandatory.**
7. **Always wear safety glasses!** Everyday glasses only have impact resistant lenses, they are not safety glasses.
8. Do **not** work under a raised Lift top deck until the load is removed and the Lift is securely blocked in the raised position with an upright support stand or equal.
9. **Never** sit, stand, or ride on the Lift top deck. Moving components can cause a loss of balance resulting in severe personal injury or death.
10. **Always** verify the Lift is resting firmly on the adjustable Floor Locks and Casters prior to raising or lowering a load on the Lift.
11. Do **not** move the Lift while the load is raised; lower the load completely before moving or storing the load. Minor adjustments (less than 12 in. (305 mm) when attempting to align battery packs or powertrain components are acceptable.
12. Care must be taken as burns can occur from touching hot parts.
13. Do not operate equipment with a damaged cord or if the equipment has been dropped or damaged – until qualified service personnel have examined it.
14. Do not let a cord hang over the edge of a table, bench, or counter, or come in contact with hot manifolds or rotating machinery.

-
15. If an extension cord is necessary, a cord with a current rating equal to or more than that of the equipment should be used. Cords with a current rating less than the equipment may overheat. Care should be taken to arrange the cord so that it will not be tripped over or pulled.
 16. Always unplug the equipment from the electrical outlet when not in use. Never use the cord to pull the plug from the outlet. Grasp the plug and pull to disconnect. Secure the control pendant and cable to prevent damage when storing.
 17. Let the equipment cool completely before putting it away. Loop the cord loosely around equipment when storing.
 18. To reduce the risk of fire, do not operate in the vicinity of open containers of flammable liquids (gasoline or similar).
 19. Adequate ventilation should be provided when working on operating internal combustion engines.
 20. Keep hair, loose clothing, fingers, and all parts of body away from moving parts. Crushing hazard!
 21. To reduce the risk of electric shock, do not use on wet surfaces or expose to rain.
 22. Use only as described in this manual. Use only BendPak recommended attachments and accessories.
 23. To reduce the risk of injury, close supervision is necessary when this product is used around children.
 24. To reduce the risk of injury, **never** attempt to lift more than the rated capacity. Refer to loading instructions.
 25. The Lift uses electrical energy; if your organization has Lockout/Tagout policies, make sure to implement them after connecting the Lift to a power source.
 26. Only operate your Lift between temperatures of +41°F to +104°F (+5°C to +40°C).
 27. The Lift should **only** be operated by authorized personnel. Keep children and untrained personnel away from the Lift.
 28. Do not make any modifications to the Lift; this voids the warranty and increases the chance of injury or property damage.
 29. Do not use the Lift while fatigued or under the influence of drugs, alcohol, or medication.
 30. Consider the work environment. Keep the work area clean. Cluttered work areas invite injuries. Keep areas well lit.
 31. **Always** make sure the Lift is secured on its safety locks before attempting to work on or near a vehicle or components.
 32. Make a thorough inspection of the product at least once a year. Replace any damaged or severely worn parts, decals, or warning labels. Replace worn or damaged parts with BendPak or BendPak approved parts and assemblies only.
 33. Keep loads balanced on the Lift Platform. Clear the area immediately if a load is in danger of falling off the Lift.
 34. Do not make any modifications to the Lift. Modifications void the warranty and increases the chance of injury or property damage. Do not modify any safety-related features in any way.
 35. Make sure all operators read and understand this Setup and Operation Manual. Keep the manual near the Lift at all times.
 36. While handling a hydraulic cylinder or a hydraulic hose, **always** wear gloves. In rare cases, a needle-like stream of hydraulic fluid (even at low pressure) can penetrate fingers, hands, or arms;

such a puncture can feel like a bite, electric shock, or a prick. While it may seem like a minor issue, any amount of hydraulic fluid injected into the human body is a serious issue. Anyone suffering such a puncture wound should be **immediately** taken to a hospital emergency room to determine the extent of the injury. Explain the circumstances of the injury to the attending physician, including what kind of hydraulic fluid was involved. Do not assume a puncture wound that could have been caused by hydraulic fluid is a minor issue; it could be life threatening.

37. Follow the instructions in this operating manual and applicable standards for daily, monthly, and annual inspections and maintenance.
38. Do not add or replace parts (i.e., batteries, wheels, power units) with items of different weights, specifications, or positions on the Lift. These changes can shift the Lift's center of gravity and compromise the stability of the Lift.
39. To reduce the risk of electric shock or fire, never overload receptacles. Refer to the labels for the proper load on receptacles.
40. Operate this Lift with extreme caution. **Stop** all operation if a malfunction occurs.
41. BendPak recommends referring to the ANSI/ALI ALIS Standard *Safety Requirements for Installation and Service* for more information about safely installing, using, and servicing your Lift.
42. Read and understand the manual sections on operating and working with the MOBI-EVS™ safely.
43. Make an inspection of the Lift **before** using it. Check for damaged, worn, or missing parts. Do not use it if you find any of these issues. Instead, take it out of service, then contact an authorized repair facility, your dealer, or BendPak at:
(800) 253-2363, option 7 then 4 or support@BendPak.com.
44. Crushing hazard and pinch points. Do not place any part of your body between the top deck and any moving part of the Lift unless visual confirmation is made that the safety lock is fully engaged, and/or that the Lift's downward motion is blocked by a Jack Stand, Forklift or other Load-Holding device that will prevent the Lift's downward movement.

Save these instructions!

Lead Acid Battery Safety

 **WARNING** **Always wear complete eye and hand protective equipment;** avoid touching your eyes while working near a battery. If battery acid contacts your skin or clothing, wash immediately with soap and water. If acid enters an eye, immediately rinse the eye with running cold water for at least 10 minutes and get medical attention as soon as possible.

 **WARNING** Do **not** bridge across battery terminals or cable clamps with tools that conduct electricity.

 **WARNING** Avoid battery acid. Neutralize battery acid spills with baking soda and water.

 **WARNING** Do not expose the battery or charger to rain.

Keep the following in mind for the safe handling of lead-acid batteries and battery chargers:





1. Verify local voltage and frequency is the same as the input specification of the Lift charger 115 VAC at 2 Amps, 47 to 63 Hz.
2. An extension cord should not be used unless absolutely necessary; **using an improper extension cord could result in a risk of fire and electric shock.** If an extension cord

must be used, make sure the pins on the extension cord plug have the same number, size, wire gauge, and shape as those of the AC power cord on the charger.







3. When handling power cords, always pull by the plug rather than by the cord; this reduces the risk of damage to both plug and cord, and it will also minimize the likelihood of electric shock resulting from that damage.
4. Carefully examine power cords. The normal wear and tear on extension and flexible cords can loosen or expose wires, creating hazardous conditions and increase your risk of contacting electrical current.
5. Verify all electrical power cords are located so that they cannot be stepped on, tripped over, or otherwise subject to damage or stress.
6. Do not operate the battery charger in a closed-in area or restrict ventilation in any way; **keep the battery charger away from any sources of ignition.**
7. Do not operate the battery charger with damaged AC power cords or plugs or DC output leads, replace worn or damaged components immediately.
8. Do not set the battery charger directly above the battery.
9. Batteries store electric charge and can give you a shock if not handled properly; make sure you are not wearing any jewelry such as rings, bracelets, necklaces, and watches when working with a lead-acid battery.
10. Keep lead-acid battery vent caps securely in place.
11. Do not expose the battery charger or any of its electrical connections to rain, snow, or extremely high, condensing humidity.
12. Never attempt to charge a visibly damaged or frozen battery, or if the battery case is bulging or leaking.

Hydraulic System Warnings

Before applying power to the hydraulic system, note the following Warnings:





-  **WARNING** Failure to observe these warnings can result in serious personal injury including, in rare cases, death.
-  **WARNING** The hydraulic hoses and connections **must** be inspected before any attempt to raise a load is made.
-  **WARNING** Verify all hydraulic hose connections and fittings, including unused auxiliary port plugs on the power unit, the cylinders, and anywhere else in the hydraulic system are tightened.
-  **WARNING** The power unit is a hydraulic pump capable of developing pressures in excess of 5,000 psi (345 BAR). A pressure relief valve is used to set the pressure at the desired level. Tampering with, adjusting, modifying, or removing the relief valve is extremely dangerous and is prohibited. Only trained hydraulic technicians are permitted to adjust the relief valve, using calibrated hydraulic pressure gauges to ensure the proper pressure setting is achieved.
-  **WARNING** Changes to the output pressure of the power unit may render the power unit incompatible with pressure limitations of other components in the hydraulic circuit.

This may cause catastrophic failure of those components, and could result in property damage, serious personal injury, or death.

-  **WARNING** The hydraulic system can contain high pressure which, if suddenly released, can cause severe injury or death.
-  **WARNING** Do **not** attempt to connect or disconnect hydraulic hoses while the equipment is loaded or while a Vehicle is on the Lift, or the hydraulic system is under pressure.
-  **WARNING** Keep bare hands away from hydraulic fluid; always wear gloves when handling hydraulic fluid, cylinders, or hydraulic hoses.
-  **WARNING** When handling hydraulic fluid, always observe the safety instructions from the manufacturer.
-  **WARNING** **Always** promptly clean any hydraulic fluid spills. If a leak is the source of the spill, lockout the Lift to prevent use until the hydraulic system is repaired.
-  **WARNING** **Use every precaution to guard against dirt entering the hydraulic system**; this could affect the operation of the Lift and the safety of anyone near the Lift.

Working with the MOBI-EVS™ and EV Batteries Safely

High-voltage cabling and components can deliver a fatal shock. Some EV components may retain hazardous voltages well after the vehicle has been shut down. Always refer to the vehicle manufacturer's instructions for safe installation/removal procedures, techniques, required tools and training.

-  **DANGER** This Lift is **not** insulated and **not** electrically grounded to Earth. The Lift will **not** provide protection from electrical current to anyone in contact with it. Stay away from the Lift if it is in contact with high voltage. Do not touch or operate the Lift until the electrical current is removed and made electrically safe in all respects.
-  **DANGER** Often a large section of an Electric Vehicle's undercarriage holds the high voltage battery; **Never breach the high voltage battery when lifting from under the Vehicle**. Use every precaution to ensure that you do not breach the battery or the floor pan.
-  **DANGER** Technicians should always be fully trained and read the Vehicle's Original Equipment Manufacturer (OEM) high voltage disabling procedures and precautions **before** working on hybrid and electric vehicles. Additional resources are available from **SAE International**.
-  **DANGER** Avoid contact with the vehicles' high-voltage cables unless the high-voltage battery has been disconnected. Proper personal protective equipment should include heavy rubber, Class 0 rated gloves. Ordinary shop gloves are **not** thick enough nor designed to protect against high voltage. The gloves should be inspected to verify no pin holes, cracks, tears, or splits are present.

-
- ⚠ DANGER** Use caution to ensure you **never** come into contact with the Vehicle's high voltage battery terminals, exposed wiring, circuitry, or other high voltage components while lifting or manipulating the vehicle's battery.
- ⚠ DANGER** Regardless of the disabling procedure in use, **always** assume that high voltage components in the vehicle are energized; **cutting, crushing, or simply touching high voltage components can result in severe injury or death.**
- ⚠ DANGER** The vehicles' high voltage circuit may require 15 minutes or more to fully discharge; refer to vehicle manufacturer's guidelines for the proper de-energizing procedure.
- ⚠ DANGER** Damaged batteries can release explosive gases and harmful liquids if damaged or mishandled.
- ⚠ DANGER** Look for color-coded high voltage cables in hybrid and electric vehicles. These colors warn of potential danger. Usually, these cables are orange, but some models use blue cables. Check with the vehicle manufacturer to identify the correct color code. Exercise extreme caution if these cables appear damaged.
- ⚠ WARNING** Most Electric Vehicles with high voltage batteries include a liquid cooling system. Take precautions to ensure that the cooling system is drained or will not spill its contents onto the Lift or the Lift's electrical components, Refer to the vehicle manufacturer's service guides.

Components

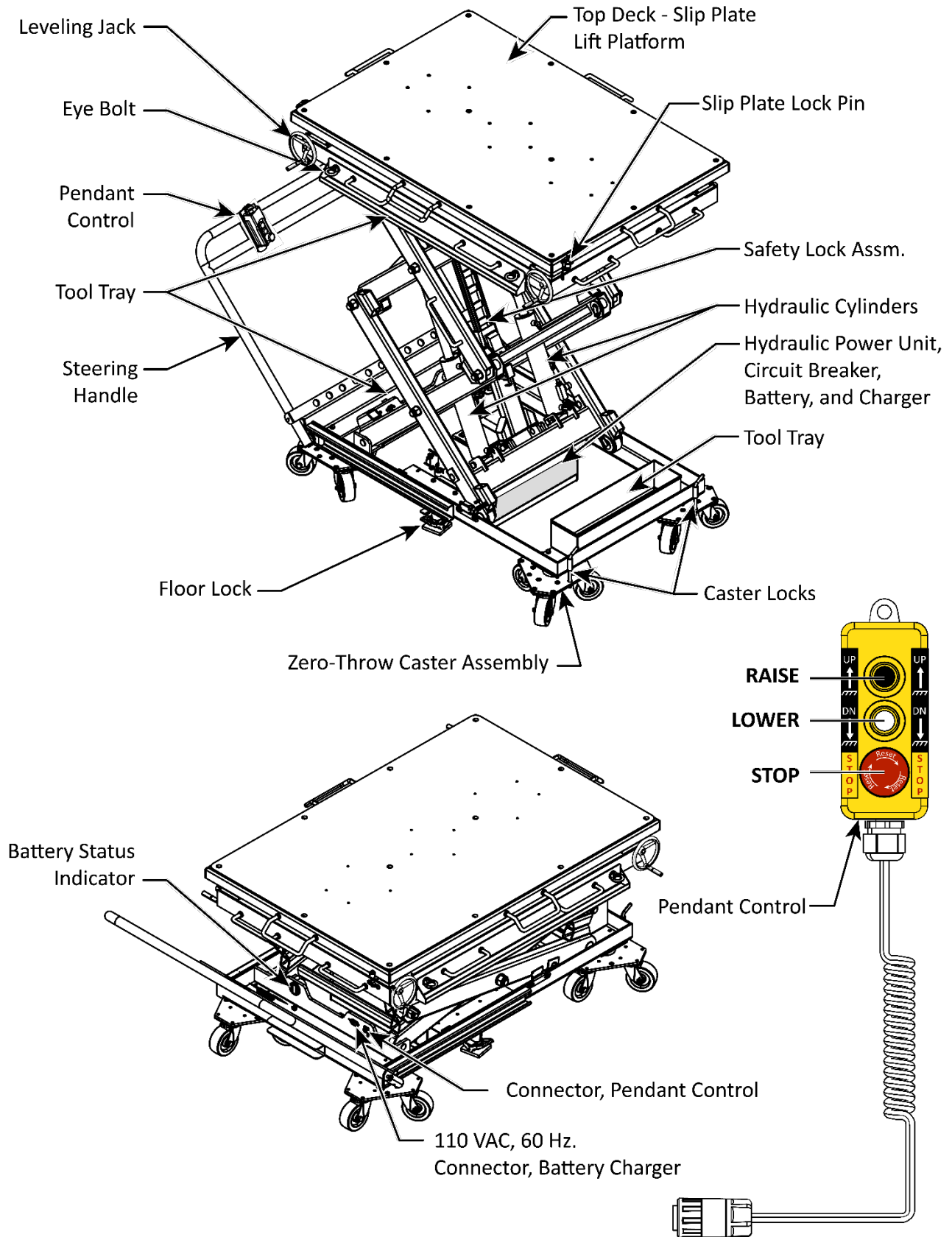

Not to scale. Not all components shown.

Specifications

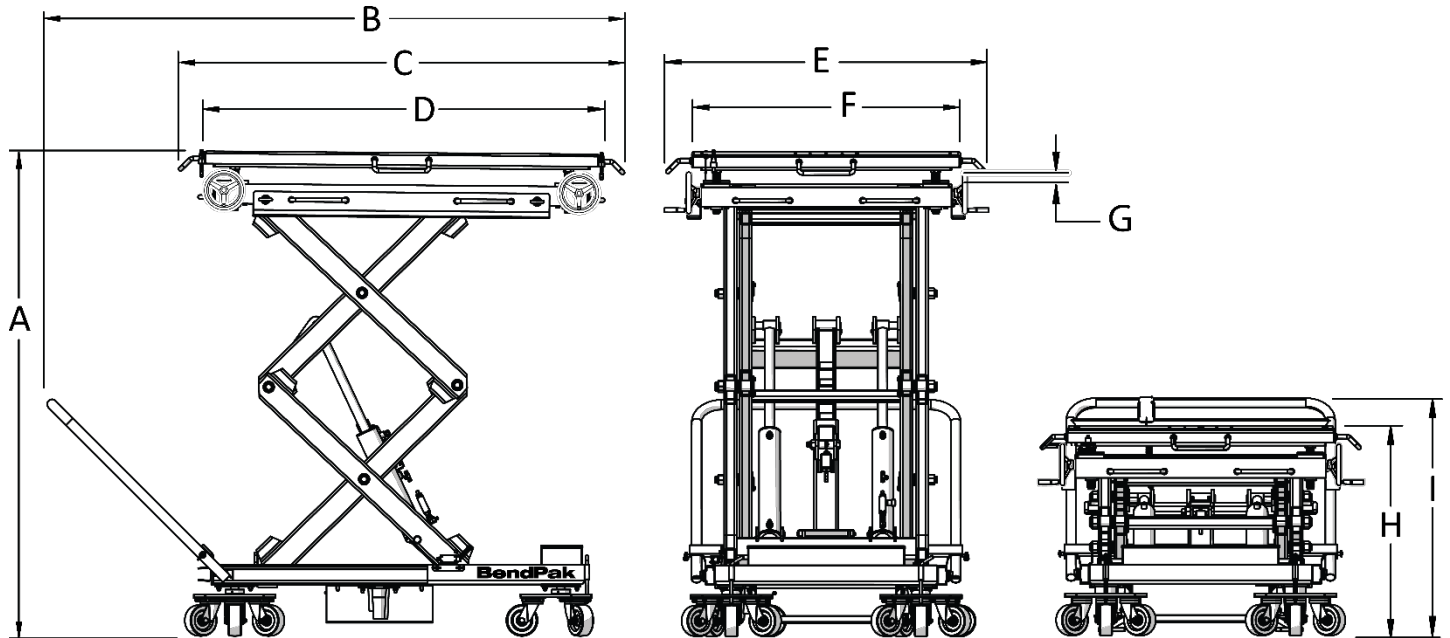

MOBI-EVS™ Battery and Powertrain Lifting System

Model	EVS3000	EVS4500
Lifting capacity	3,000 lbs. (1,361 kg)	4,500 lbs. (2,041 kg)
A - Maximum Rise	77.75 in. (1,972 mm)	
B - Overall length	91.25 in. (2,318 mm)	
C - Top Deck length (with handles)	71.25 in. (1,807 mm)	
D - Top Deck Length	63 in. (1,600 mm)	
E - Overall Width (with handles)	53 in (1,348 mm)	
F - Top Deck Width	42.75 in. (1,088 mm)	
G - Leveling Jack Max. Adjustment	1.5 in. (38 mm)	
H - Minimum Deck Height	34.25 in. (868 mm)	
I - Height of Steering Handle	39.25 in. (997 mm)	
Motor	12VDC	
Operating Hydraulic Pressure at Max. Load	1250 psi	1720 psi
Battery Charger	Input: 120 VAC, 60 Hz. / Output: 12VDC, 15A	
Battery Charge Time	10-12 Hours to full charge from ~20%	
Lifting Time	~18 seconds	
Weight	1,918 lbs. (870 kg)	

All dimensions measured with Leveling Jacks at maximum height 1.5 in. (38 mm). Specifications subject to change without notice.

Steering Handle - Stowed Dimension

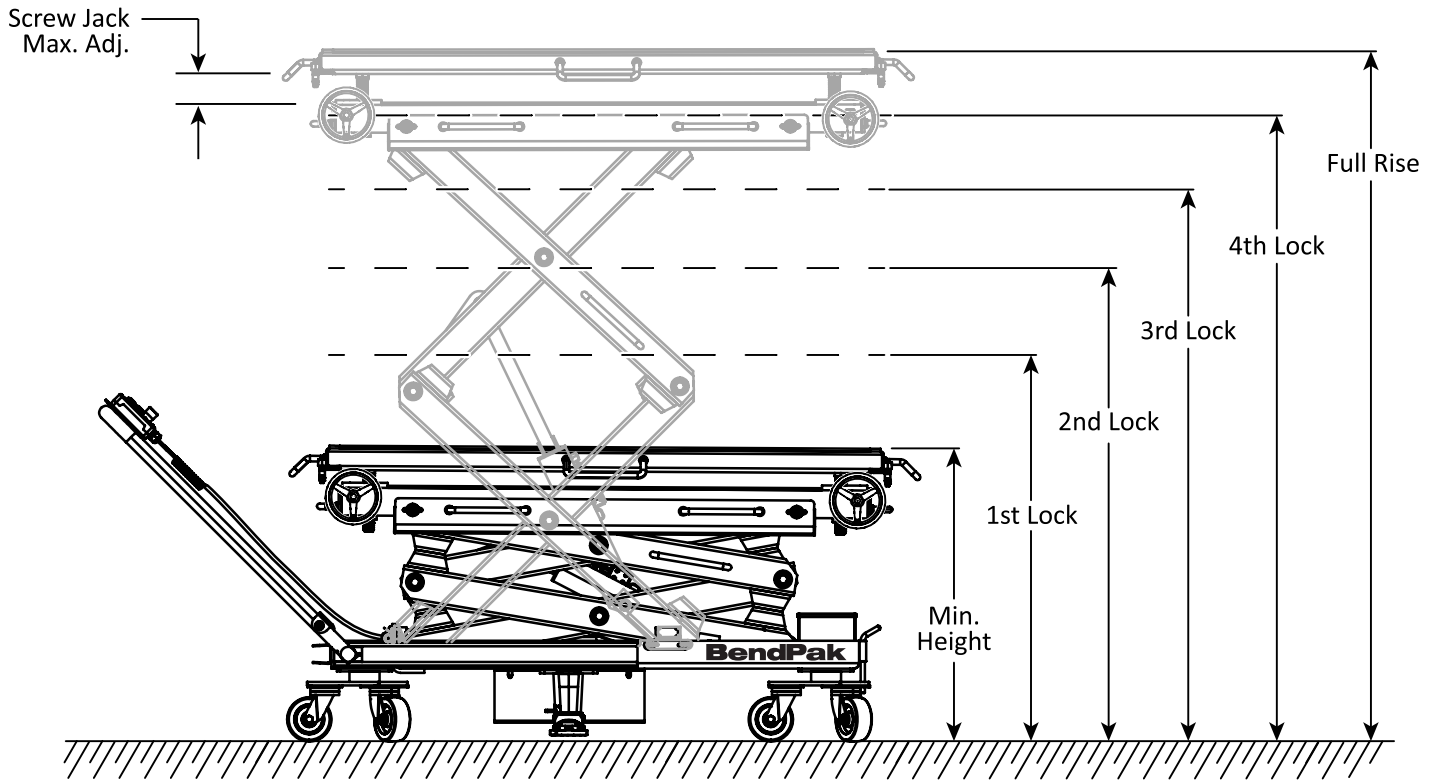
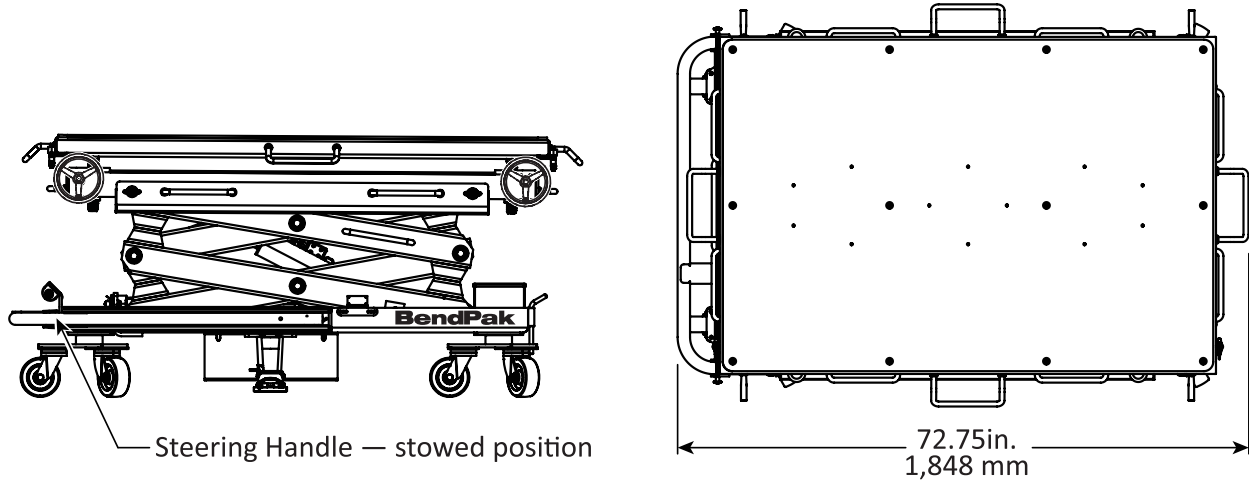

Safety Lock Position	EVS3000 / EVS4500
Min. Height	34.25 in. (868 mm)
1 st Lock	44.75 in. (1,136 mm)
2 nd Lock	54.5 in. (1,386 mm)
3 rd Lock	63.5 in. (1,612 mm)
4 th Lock	71.75 in. (1,825 mm)
Full Rise	77.75 in. (1,972 mm)
Leveling Jack Max. Adjustment	1.5 in. (38 mm)

Note: All dimensions shown with Leveling Jacks adjusted to maximum 1.5 in. (38 mm). Specifications subject to change without notice.

Setup

This section describes preparing the MOBI-EVS Lifting System for operation. Only fully trained personnel should be involved in the set-up and operation of this equipment. **Always pay attention.** Use appropriate tools and equipment. Stay clear of moving parts and live electrical components.

BendPak recommends referring to the ANSI/ALI ALIS Standard *Safety Requirements for Installation and Service* for more information on safe setup, operation, and service of your Lift.

⚠ WARNING Always use the proper tools, such as a forklift, shop crane or hoist, to move heavy components.

⚠ WARNING You must always wear the proper protective equipment during setup and operation of this Lift: leather gloves, steel-toed boots, back belts, and hearing protection.

⚠ WARNING **Use only the factory-supplied parts that came with your Lift.** If you use parts from a different source, you void your warranty and compromise the safety of everyone who installs or uses the Lift. If you are missing parts, visit bendpak.com/support or by phone at **(800) 253-2363** option 7, then 4.

Setup Checklist

1. Read and understand this manual before beginning the setup.
2. Read and pay careful attention to all cautions, warnings, and danger indications in this manual.
3. Read and pay careful attention to all labels on the Lift detailing cautions, warnings, and dangers.
4. Gather the required tools and supplies.
5. Select a site for setup and operation.
6. Unpack the MOBI-EVS. Remove the shipping crate.
7. Lift the MOBI-EVS off the shipping pallet.
8. Perform the initial hydraulic fluid fill procedure.
9. Reset the Circuit Breaker.
10. Connect the Control Pendant to the Lift.
11. Charge the MOBI-EVS if $\leq 20\%$ charge.
12. Remove the Slip Plate Shipping Bolts and attach the Slip Plate Lock Pins and lanyards.
13. Install the Leveling Jack Hand Wheel Handles.
14. Extend and lock the Steering Handle.
15. Perform an Operational Test.
16. Review the Final Checklist.
17. Leave the Manual at the Lift for the Owner/Operator.

Tools and Supplies required:

- Forklift, or shop crane/hoist
- Pry Bar
- Hammer
- Screwdrivers
- Open End Wrenches
- Hex Keys
- Tape Measure
- Tie down straps
- Hydraulic Fluid
3.5 Qt. (3.3 L)
- White lithium grease Spray
- #2 Heavy White Lithium Grease

Select a Site for Setup and Operation

Find a location for setup near where you will be using the Lift. Keep the following in mind when selecting a site:

- **Clearance.** You must have adequate unobstructed space on all sides and enough space above the Lift for assembly and testing.
- **Operator.** The operator at the control pendant **must** maintain a full, unobstructed view of the Lift at all times.
- **Level floor.** Inspect the floor and check for defective concrete. Verify the floor is dry, level, in good condition, and has a minimum compressive strength of 500 psi.

 **DANGER** Do not operate the Lift on a surface with a slope of 3° or greater. A sloped surface can cause a loss of lift control/balance leading to property damage, severe personal injury, or death.

- **Outdoor operation. Outdoor use is prohibited.** This Lift is intended for indoor use only.

Unpacking

To remove the Lift from its shipping crate, gather the following required tools: a hammer, pry bar, and lifting equipment such as a hoist, shop crane, or forklift. Follow the procedure described below.

 **DANGER** The MOBI-EVS is heavy. Lifting the MOBI-EVS is to be accomplished by competent, experienced personnel ensuring the Lift is properly rigged and balanced for lifting. Installation personnel should have knowledge, training, and experience in safe lifting, and rigging of heavy objects.

 **WARNING** You must always wear the proper protective equipment during setup and operation of this Lift: leather gloves, steel-toed boots, back belts, hard hats, and hearing protection.

 **WARNING** Exercise caution. Do not damage the Lift while removing from the shipping crate.

To unpack the MOBI-EVS Lifting System:

1. Use a pry bar and hammer to remove the top and all four sides of the shipping crate. See figure below.
2. Remove the MOBI-EVS component parts on top of and below the Lift. Set these components aside where they will not be lost or damaged.
3. Remove any strapping and fasteners securing the Lift to the pallet.
4. Verify that the weight of the MOBI-EVS does not exceed the maximum safe working load of the lifting equipment.
5. Verify the area is clear around the Lift and there are no overhead obstructions that will interfere with removing the Lift from the pallet.
6. Move the lifting equipment to the MOBI-EVS.
7. Lifting slings are prepositioned and shipped with the MOBI-EVS. Attach these lifting slings to the lifting equipment so that all four sling ends meet at a single lifting point above the center of the MOBI-EVS.
 - a. Never tie knots in the lifting slings.
 - b. Verify the slings are routed through the eyebolts on both sides of the Lift
 - c. The slings may have shifted in transit. Verify the slings are routed to equalize the load between the lifting slings.
8. Keep personnel clear of the lifting area.
9. Once the slings are secure, slowly lift the load a few inches off the pallet and verify the slings are positioned correctly and the load is supported safely and evenly.
10. Carefully and slowly lift the MOBI-EVS clear of the shipping pallet.
11. Remove the pallet and carefully lower the MOBI-EVS to the ground.

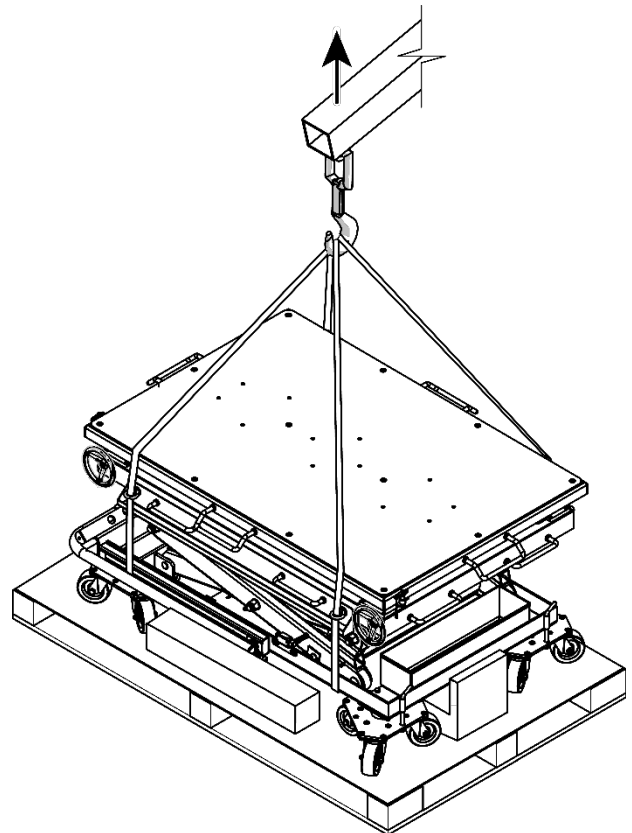
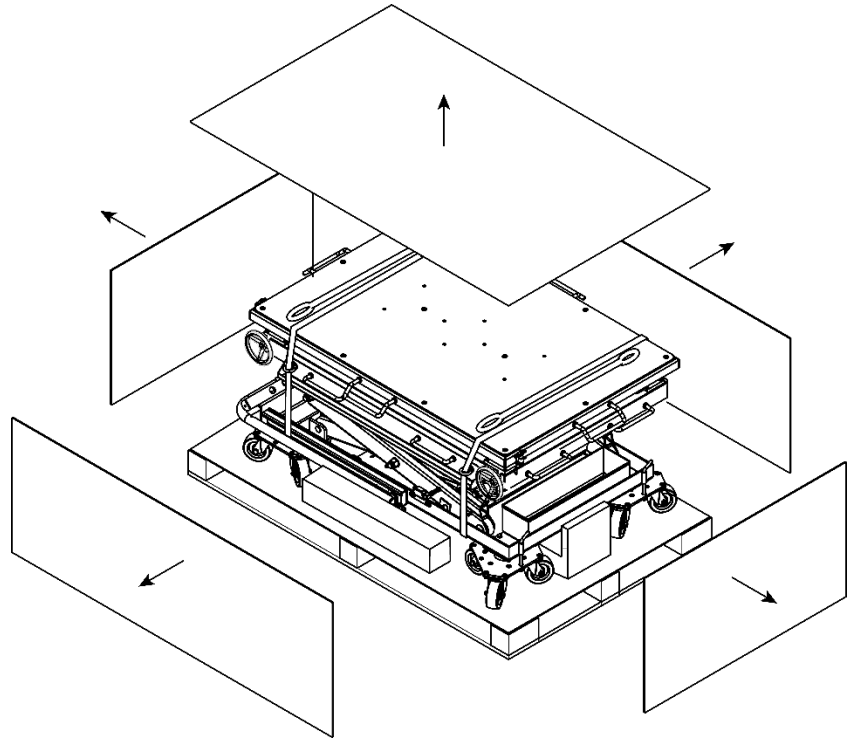

Initial Hydraulic Fluid Fill Procedure

⚠ DANGER Crushing hazard and pinch points. Do not place any part of your body between the top deck and any moving part of the Lift unless the Lift is blocked by a Jack Stand or equal device that will prevent downward movement.

⚠ WARNING Hydraulic fluid under pressure is dangerous. You must always wear OSHA-approved (publication 3151) Personal Protective Equipment when in contact with hydraulic fluid: eye protection, leather gloves, and steel-toed boots are mandatory.

To fill the Hydraulic Fluid Reservoir:

1. Remove the Lifting Slings from under the Lift and reposition to under the Lifting Platform. The slings are to be positioned in front of the hand wheel and Jack Screw as shown on **BOTH** ends of the lift. Refer to the figure below.
2. Route the other Lifting Sling on the opposite end of the Lift.
3. Attach the Slings to the lifting equipment and **slowly** lift the platform.
4. While lifting, pay attention to the safety lock and its solenoid at the center of the scissor mechanism. You will hear an audible click as the Lock Bar passes over the Lock Blocks. When the lift platform is high enough to allow access to the electrical enclosure in the center of the Lift, lower the lift platform until the Safety Lock Bar engages the Safety Block.
5. Verify the Safety Lock is properly engaged on the Safety Block.
6. If the Lifting device can support the upper platform while working in the Lift leave it in place to prevent any downward movement.

Alternatively, the scissor mechanism's downward movement may be blocked with Jack Stands or equivalent as shown.
7. Remove the Parts Box from inside the scissor mechanism.

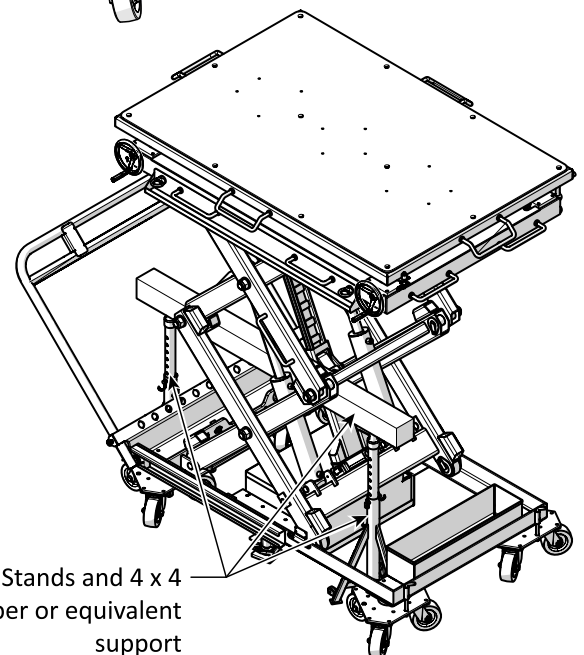
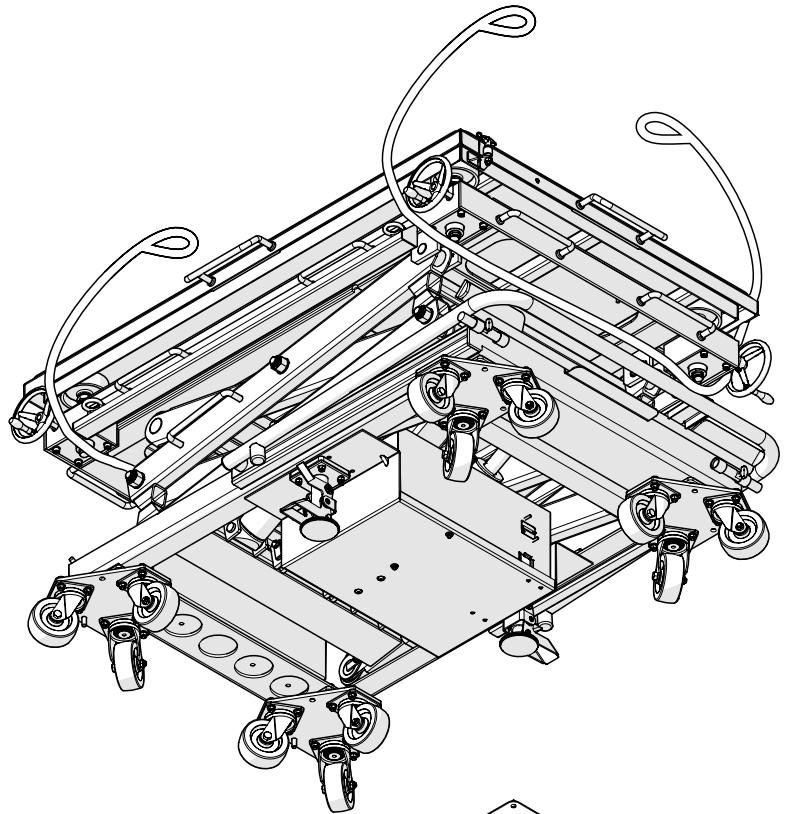

- After the top deck has been made secure and is in a safe position, locate the circuit breaker on the electronics enclosure. Verify the circuit breaker is in the disconnected position as indicated by the figure below. If the reset bar cannot be seen, press the button as indicated in the figure. The Reset Bar should rotate out.

⚠ WARNING When the electronics enclosure cover is removed, live electrical terminals are exposed. The MOBI-EVS Lift utilizes a 12 VDC battery of significant capacity. Use metal tools with caution and do not touch electrically live terminals with your hands or tools. Bridging across a live terminal and the frame of the Lift will result in arcing and a large electrical current flow. This could result in severe personal injury or damage to the battery, the power unit, and/or its controls.

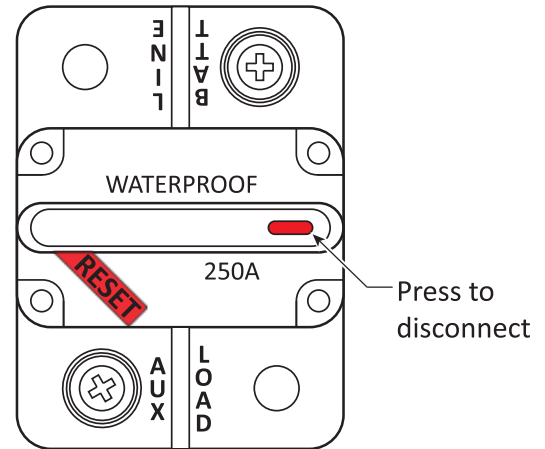

- Retrieve a Phillips screwdriver and remove the two screws securing the cover of the electronics enclosure. Remove the cover and set aside where it will not be damaged.

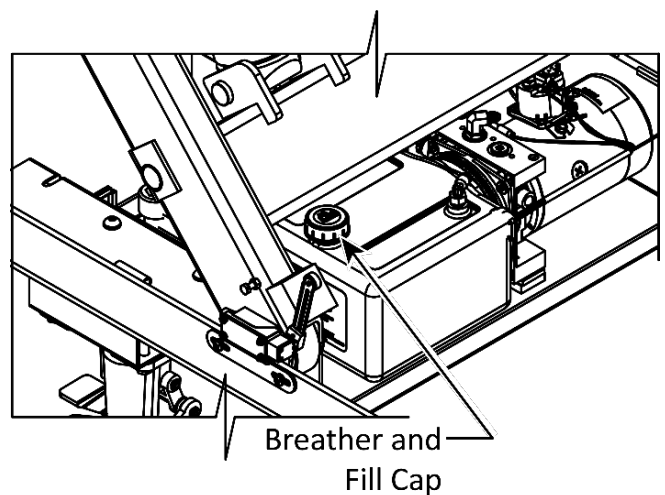
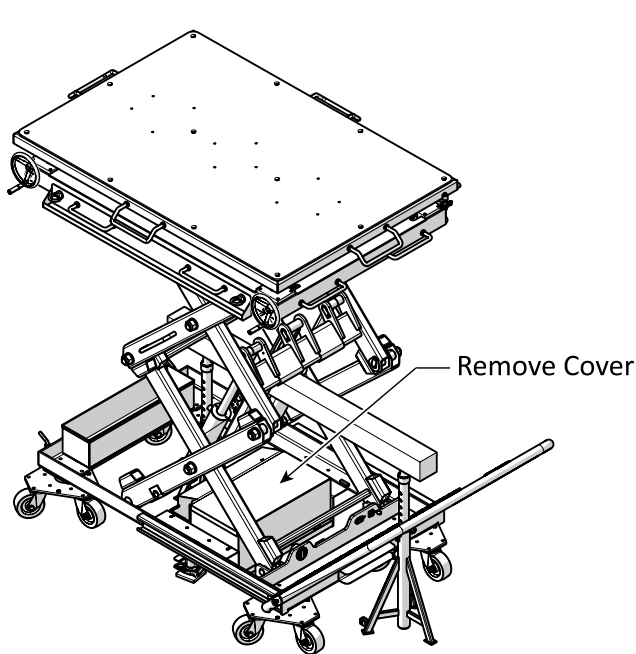

- Locate and remove the power unit's reservoir breather / fill cap.
- Use an appropriate funnel with a filter to deliver approximately 3.5 Quarts (3.3 liters) of hydraulic fluid into the reservoir. Compatible fluids include any general-purpose ISO-32, ISO-46, or ISO-68 hydraulic oil or approved automatic transmission fluids such as Dexron III, Dexron VI, Mercon V, Mercon LV, Shell Tellus S4 / S3 / S2, or any synthetic multi-vehicle automatic transmission fluid. Do not overfill. The total reservoir capacity is 3 liters.
- Replace the fill cap and promptly clean any spilled hydraulic fluid.
- Replace the Electronics Enclosure Cover and secure using the two screws previously removed.

14. Open the Parts Box and retrieve the Control Pendant. Push the **Stop** button. It should click and remain in the down “off” position.
15. Connect the Control Pendant’s plug into the mating receptacle on the Lift. The receptacle is mounted on the Lift’s base near the steering handle and the charging port. Remove the protective cover to mate the connectors. These connectors are “keyed” and must be correctly aligned to mate. Rotate the Control Pendant’s connector until it snaps into its mate. Then rotate the collar on the outside of the connector to secure. Refer to the figure below.

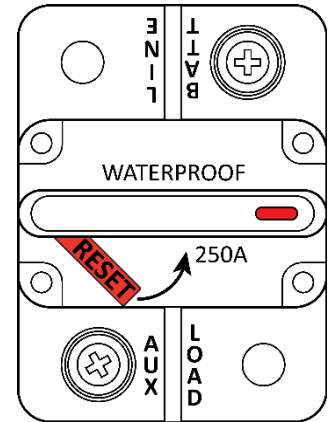
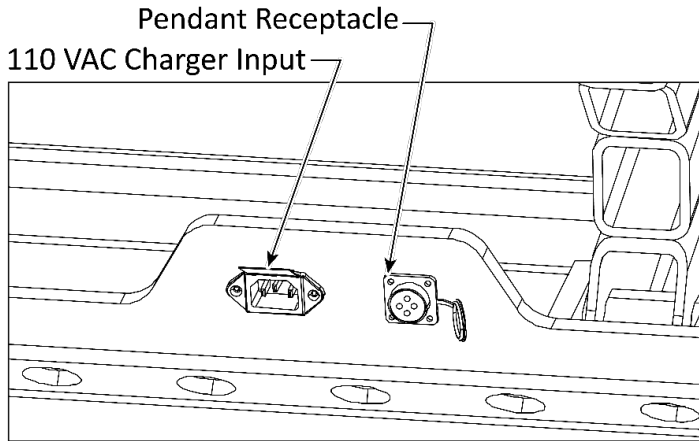

16. Reset the Circuit Breaker by rotating the Reset Bar upwards. Refer to the figure on the above.
17. Rotate the **Stop** button clockwise to apply power to the Lift.

IMPORTANT! The Battery Status Indicator will not function, and the battery will not charge until the Control Pendant is connected to the Lift and the Stop button is in the operate position. Rotate the Stop button clockwise to verify the Stop button is in the operating position.

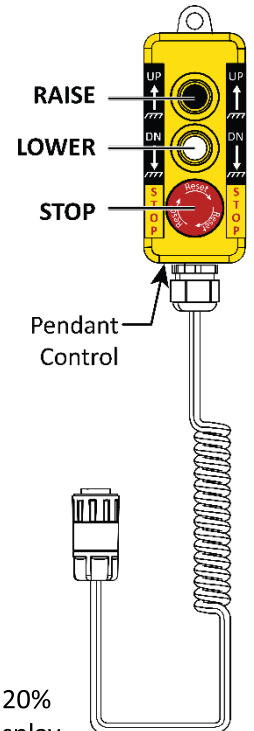

18. Locate the Battery Status Indicator.
 - a. If the battery status indicates 20% or higher, then proceed to **step 20**.
 - b. If the battery status is less than 20% or has no indication, proceed to **steps 19**.

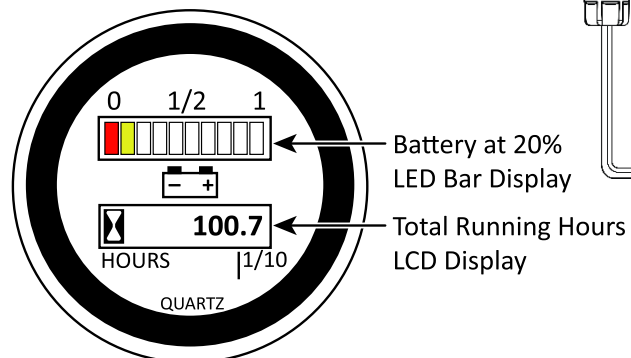
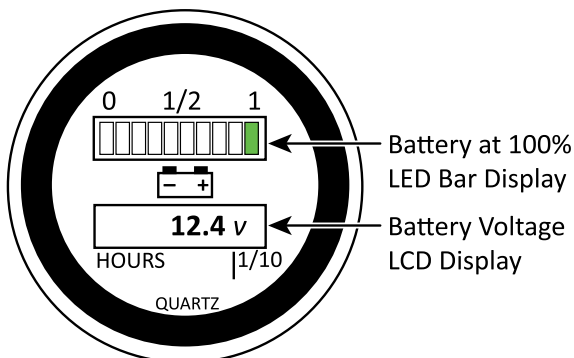

19. Locate the power cord (5324203).
 - a. Plug the power cord into the MOBI-EVS and then plug the opposite end into a 110 VAC power outlet.
 - b. Battery charging is automated. Allow the battery to charge until $\approx 20\%$ is displayed on the battery status indicator.
 - c. Proceed to step 20.
20. Remove any tools, parts and supplies from under the Lift or in the scissor mechanism.
21. Press the **Up** button briefly to raise the Lift off the Jack Stands or Forklift.
22. Remove the Jack Stands or Forklift to allow the top deck to descend.
23. Press the **Down** button until the top deck is resting on its stops or is resting on a Safety Lock at a comfortable height to complete the setup work.

Install the Slip Plate Lock Pins and Lanyard:

To install the Slip Plate Lock Pins and Lanyard:

1. Retrieve the two Slip Plate Lock Pins with Lanyards from the Parts Box.
2. Locate and remove the two M6 Screws and M6 Hex Nuts on the Slip Plate using a pair of open end wrenches. Refer to the figure below.

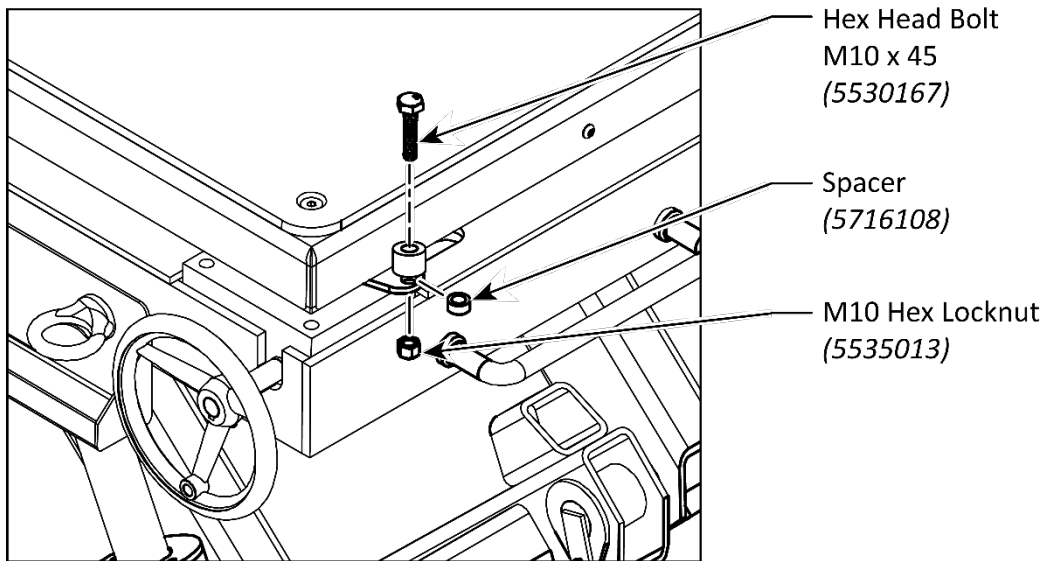

3. Attach the Lanyard to the Slip Plate as shown in the figures on the next page using the M6 Button Head Socket Screw and M6 Nylock Nut.
4. Secure the Slip Plate by inserting the Slip Plate Lock Pins into the Locking Tube and down through the Lock Bracket.
5. Remove the Slip Plate Lock Pins, Grasp the Slip Plate Handles and verify the Slip Plate moves from side to side as well as fore and aft.
6. Return the Slip Plate Lock Pins to their brackets to secure the Slip Plate. Refer to the figure on the next page.

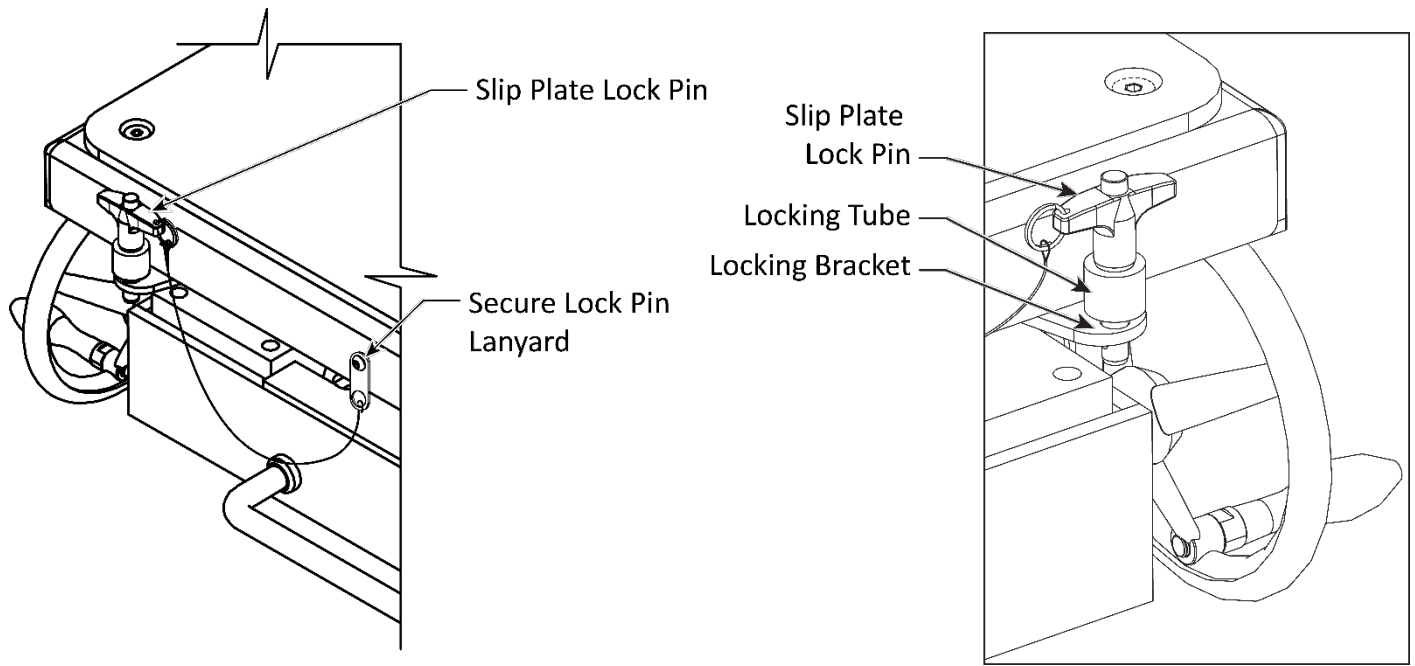

Install the Leveling Jack Hand Wheel Handles

To install the Leveling Jack Handles:

1. Retrieve the four Handles from the Parts Box.
2. Thread one Handle into each Hand Wheel on each corner of the Lift.
3. Tighten the Handles using an open end wrench.
4. Operate each Leveling Jack up and down to verify operation.

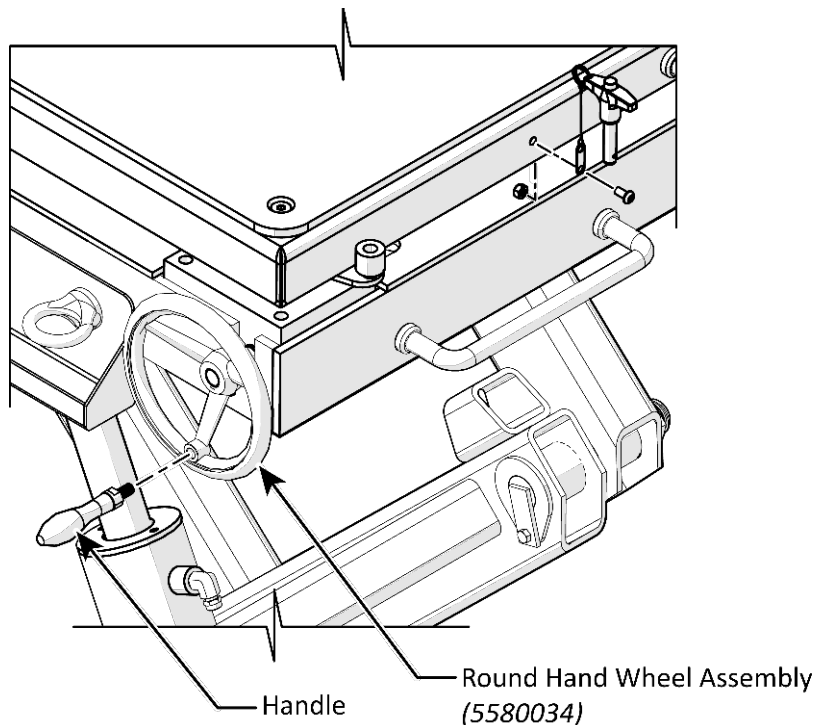

Extend and Lock the Steering Handle Assembly

The Steering Handle Assembly is shipped in the stowed position.

To Extend and Lock the Steering Handle Assembly:

1. Pull the Steering Handle straight out from the lift. Refer to the figure below.
2. Rotate the Handle up to its operating position.
3. Slide both lock pins toward the handle to hold it in position.
4. Tighten the T-Screw on **both** lock pins to secure the pins in place.
5. Reverse this procedure to return the steering handle to its stowed position.

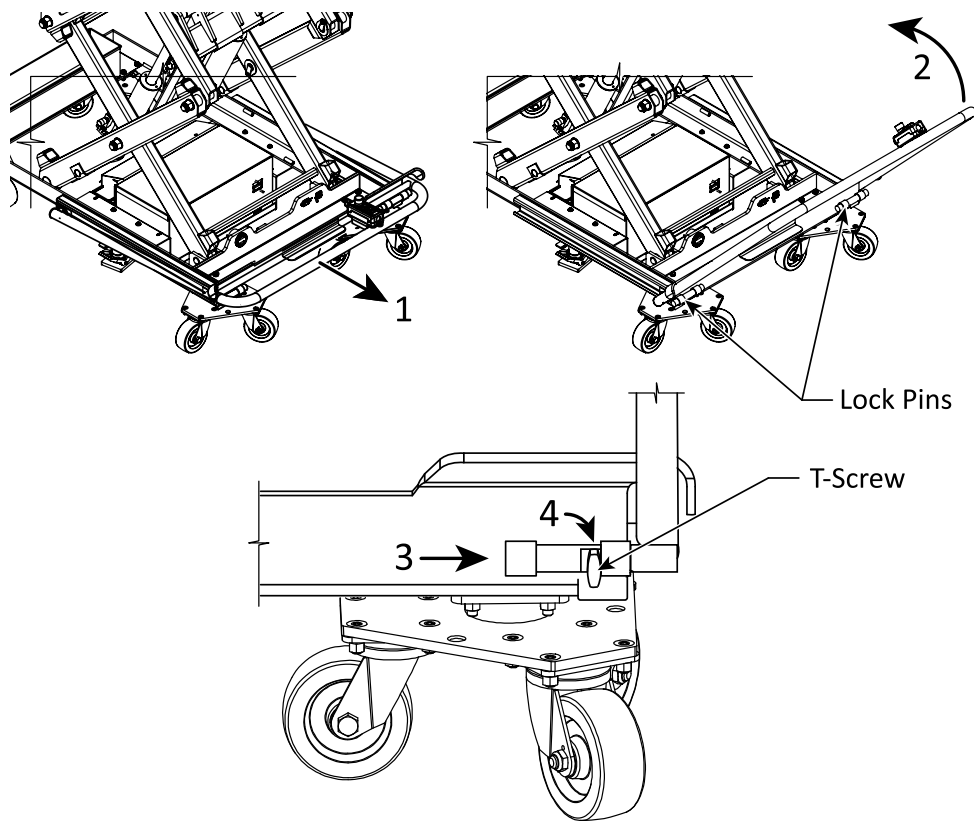

Perform an Operational Test

Before putting your Lift into normal operation, BendPak recommends raising and lowering it several times with a typical load on the Lift. This will help the operator get a feel for how to operate the controls and move any residual air out of the Hydraulic System.

⚠ DANGER Lifts are dangerous tools when used by inexperienced or impaired technicians. When you hear the words “automotive lift,” your brain should automatically register the fact that lifting a heavy object is a serious endeavor with life-threatening risks if mandatory lifting precautions are ignored.

During the Operational Test, check for proper operation. Do not raise any additional loads until a thorough Operational Test has been completed.

⚠ WARNING Never raise a load whose weight exceeds the rated capacity of the Lift. Do not leave the controls until the Lift is engaged on its safety locks. Only trained personnel should raise or lower the Lift.

To perform an Operational Test:

1. Verify all the areas in the **Setup Checklist** have been completed.
2. Follow the instructions in **Positioning and Raising the Lift** to safely raise and lower a load on the Lift.

⚠ DANGER Follow the instructions carefully when it comes to contacting the manufacturer’s recommended Lifting Points on the components being lifted. Powertrains, Transaxles, EV batteries and other components may have centers of gravity that are not obvious. If you do not follow the manufacturer’s instructions for lifting, the load may become unstable and fall, which could damage the Vehicle, the component, the Lift, and injure or even kill anyone under the Vehicle or component.

3. Adjust the Rubber Lift Pads under the load so the Pads are directly under the Lifting Points for the load you are raising.
4. Place the load on the Lift Pads, then secure using load tie-down straps or an equivalent.
5. Verify the load is stable.
6. Press the **Up** button to raise the Lift.
7. Raise the Lift just a few inches.
8. Verify the load is stable and all Lift Pads are making solid contact with the load Lifting Points.

If any of the Lift Pads are **not** making solid contact with the Lifting Points, carefully lower the Lift and start over again; the Lift Pads **must** make solid contact with the Load.

9. Raise the Load approximately three feet off the ground, then release the **Up** button, then *press and hold* the **Down** button to lower the Lift.

NOTICE Residual air in the Hydraulic System can cause the Lift to shake, move erratically, or squeak; this is normal when you first begin to use the Lift. As the Hydraulic System self-bleeds air out of the system the sounds should cease.

10. Wait for one minute.

⚠ WARNING The power unit is not a constant duty motor; **it cannot be run continuously.**

11. Repeat the process to raise the Load.
12. If the Lift is working without shaking, moving erratically, or squeaking, there is no need to repeat the procedure. If the Lift is shaking, moving erratically, or squeaking, repeat the procedure one more time. If you continue to have issues, refer to **Troubleshooting** for assistance.
13. Press the **Down** button. When the Lift is returned to its lowest position, **adjust the Limit Switch** to trigger at some height.
14. Push the Up button until the Microswitch is triggered and stops the Lift.
If the Lift does not stop rising when the Microswitch is triggered, refer to **Troubleshooting** for assistance.

⚠ CAUTION Do not put the Lift into normal operation until you have confirmed that triggering the Microswitch stops the Lift Arms from rising.

15. Press the **Down** button to return the Lift to its lowest position. The Load may now be removed.

Final Checklist

Verify the list below has been completed before putting the Lift into normal operation:

- Review the **Setup Checklist** and verify all steps have been performed.
- Verify the battery status charge indication is greater than or equal to 20%. Charge the battery if less than 20%.
- Check the hydraulic fluid reservoir; it must be full of approved hydraulic fluid or automatic transmission fluid. **The Power Unit can be damaged by running it without enough fluid.**
- Check the Hydraulic System for leaks. Verify all hydraulic hose connections, hydraulic fittings, and auxiliary port plugs on the Lift and power unit are tight.
- Verify all Scissor Pivot Points and fasteners are secure.
- Lubricate all scissor pivot points with white lithium grease.
- Verify the safety lock and channel are free and clear of debris that would prevent the safety lock from engaging.
- Verify an Operational Test has been successfully performed.
- Verify there are no obstructions around or above the Lift.





Leave the Manual with the Owner/Operator

Leave this *Setup and Operation Manual* with the owner/operator so that it is available to everyone who will use the Lift.



Operation

This section describes how to operate your Lift.

-  **DANGER** When fully loaded, the MOBI-EVS is heavy. Once the Lift is in motion the operator will not be able to stop it quickly. The operator should always push/pull the MOBI-EVS in a slow, controlled manner. Clear the intended Lift route. Watch for and then warn co-workers of the heavy load approaching.
-  **DANGER** Falling components may cause severe injury or death. Always secure the load when lifting, lowering, or moving vehicle components. Use appropriate straps or tie downs to prevent load movement. Eyebolts are provided as tie down points on the sides of the Lift. Always lower the load before moving.
-  **DANGER** Crushing hazard and pinch points. Do not place any part of your body between the top deck and any moving part of the Lift, unless the Lift's motion is blocked by a Jack Stand, Forklift or equal device that will prevent the Lift's downward movement.
-  **WARNING** Hydraulic Fluid under pressure is dangerous. You must always wear OSHA-approved (publication 3151) Personal Protective Equipment when handling hydraulic fluid or components: eye protection, leather gloves, and steel-toed boots are mandatory.

Lift Operation Safety

BendPak recommends referring to the latest version of the ANSI/ALI ALIS Standard *Safety Requirements for Installation and Service* for more information about safely installing, using, and servicing your Lift. Publications are available from the Automotive Lift Institute. Visit ALI on the web at www.autolift.org.

-  **WARNING** **Never** work under the top deck until the load has been removed. Do not place any part of your body between the top deck and any moving part of the Lift unless visual confirmation is made that the safety lock is fully engaged, and/or that the Lift's downward motion is blocked by a Jack Stand, Forklift or other Load-Holding device that will prevent the Lift's downward movement.

Before you raise or lower a load using your Lift, do the following:

- **Test and inspect the Lift. Before each use**, check the Lift for any missing, heavily worn, or damaged components or controls. Do not operate the Lift if safety or maintenance issues are present; take it out of service, then contact your dealer, visit bendpak.com/support, by email at support@bendpak.com, or by phone at **(800) 253-2363**, select option 7, then 4.
- **Clearance.** Adequate space on all sides and space above is required to allow raising and lowering of the load.
- **Check the operators.** Make sure everyone who operates the Lift has been trained in its use, has read the labels on the unit, and has read the manual. Only the operator should be within 30-feet of the Lift when it is in motion.
- **Check for safety.** Make sure everyone who is going to be near the Lift is aware of its presence and takes appropriate safety measures. When lowering the Lift, do not leave it until it is fully lowered. Do not allow children to operate the Lift. Do not allow anyone under the influence of drugs or alcohol to operate the Lift.

- **Use the Emergency Stop** button to stop the Lift at any time.
- **Use the Floor Locks** when Lifting or lowering a load. The Floor Locks will prevent unintended Lift movement when operating the Lift.
- **Operator.** The operator at the Control Pendant must have a full, unobstructed view of the Lift at all times.
- **Level floor.** Inspect the floor and check for defective concrete. Verify the floor is in good condition, dry, level, and has a minimum compressive strength of 500 psi. Do not attempt to roll the Lift over broken or severely cracked concrete.

⚠ WARNING Do not operate the Lift on a surface with a slope equal to or greater than 3°. A sloped surface can cause a loss of lift control/balance leading to property damage, personal injury, or death.

- **Operating temperature.** The Lift is designed to be used between temperatures of +41° to 104°F (+5° to 40°C).
- **Outdoor installation.** This Lift is designed for indoor use only. **Outdoor use is prohibited.**
- **Do not lift personnel.** This Lift is intended to raise and lower vehicle components. Use it for its intended purpose only. **Use of this equipment to lift personnel is prohibited.**
- **Protect your hands.** Never raise a load while your hands are in a position to be pinched between the Lift's load and a vehicle or component above. Never put your hands or a co-workers hands where they cannot be seen.
- **Always secure the load.** Unsecured loads can shift or fall during transit. Verify the load is adequately secured to the Lift with appropriate straps or rigging.

Additional Operating Information

Keep the following in mind when operating the MOBI-EVS Lift:

- **Before** operation, verify the Lift has a sufficient battery charge (>20%), recharge if necessary.
- Your Lift is portable; if you move it to a new location, verify the location has a hard, flat, level, and dry surface.
- Do not use the Lift in an explosive or flammable location.
- Always verify the Lift's top deck is lowered completely **prior** to moving the Lift with or without a load across a Floor.

⚠ WARNING **Never** move the Lift across a floor when the top deck is elevated. Minor adjustments less than 12 in. (305 mm) when attempting to align battery packs or Power Train components are acceptable.

⚠ WARNING Do not exceed the rated lifting capacity of the Lift at any time for any reason; you could damage the Lift, the components, or the load on the Lift, and injure anyone in the vicinity of the Lift.

- **Keep all body parts away from the Lift when the Lift is in use;** prevent hands and tools from becoming trapped between the vehicle and the top deck.
- **Always secure the load to the top deck using the eye bolts and appropriately rated lifting slings.**

⚠ WARNING **Never** stand or sit on the top deck to work.

- Do **not** load the Lift with loose or unstable materials.
- Do **not** attempt to move or adjust the load while the Lift is in motion.

- Do **not** leave the top deck loaded for extended periods of time.
- Do **not** lift personnel.

The Control Pendant

The operation of the Lift is controlled through the pendant.

Pendant Controls:

- **STOP** Button. Push for Stop. Rotate clockwise to reset and restore power. Removes power from the Power Unit, Lowering Solenoid and Battery Charger.
- **UP** button. Applies Power to the Hydraulic Power unit. Moves the top deck up.
- **DN** Down button. Releases the safety lock to lower the top deck and engages the lowering solenoid. Read **About Safety Locks** for a more detailed explanation.

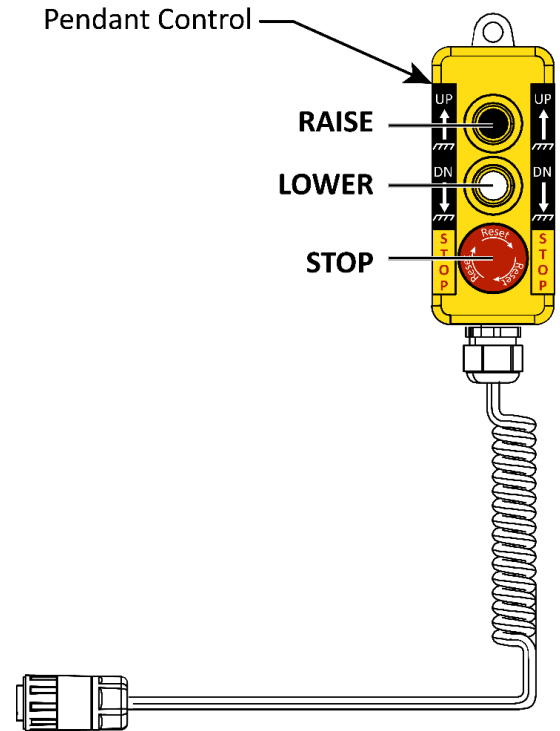

Figure not to scale.

The Flow Control Valve

The Flow Control Valve affects the speed at which the top deck moves up and down by adjusting the flow of hydraulic oil between the cylinders and the power unit.

- ⚠ DANGER** **Never reach into the Lift to adjust the flow control while the Lift is in motion. Serious personal injury may result.**
- ⚠ DANGER** **Crushing hazard and pinch points. Do not place any part of your body between the top deck and any moving part of the Lift unless visual confirmation is made that the safety lock is fully engaged, and/or that the Lift's downward motion is blocked by a Jack Stand, Forklift or other Load-Holding device that will prevent the Lift's downward movement.**

To adjust the Flow Control:

1. Access the Flow Control Valve by raising the Lift's top deck (press UP on the Pendant).
2. Bring the top deck to rest on the second or third safety lock. Note the speed at which the top deck rises.
3. Make small adjustments to the valve $\approx 1/4$ turn at a time.
 - a. To increase the speed, **open** the valve (turn counterclockwise).
 - b. To decrease the speed, **close** the valve (turn clockwise).
4. Raise the top deck and note the speed. If the speed is acceptable, lower the top deck and proceed with Lifting operations.

Important

The weight on the top deck will affect the Lift's lowering speed. The lighter the load, the slower the lowering speed.

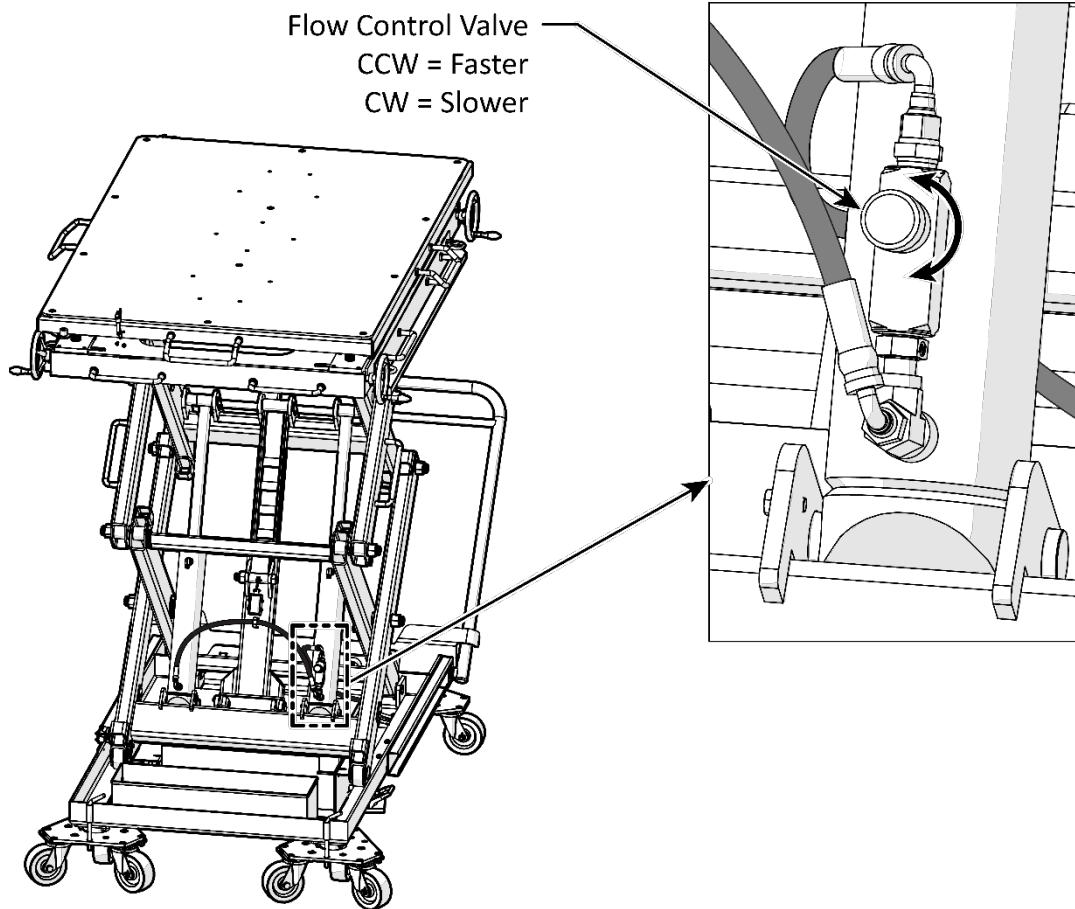
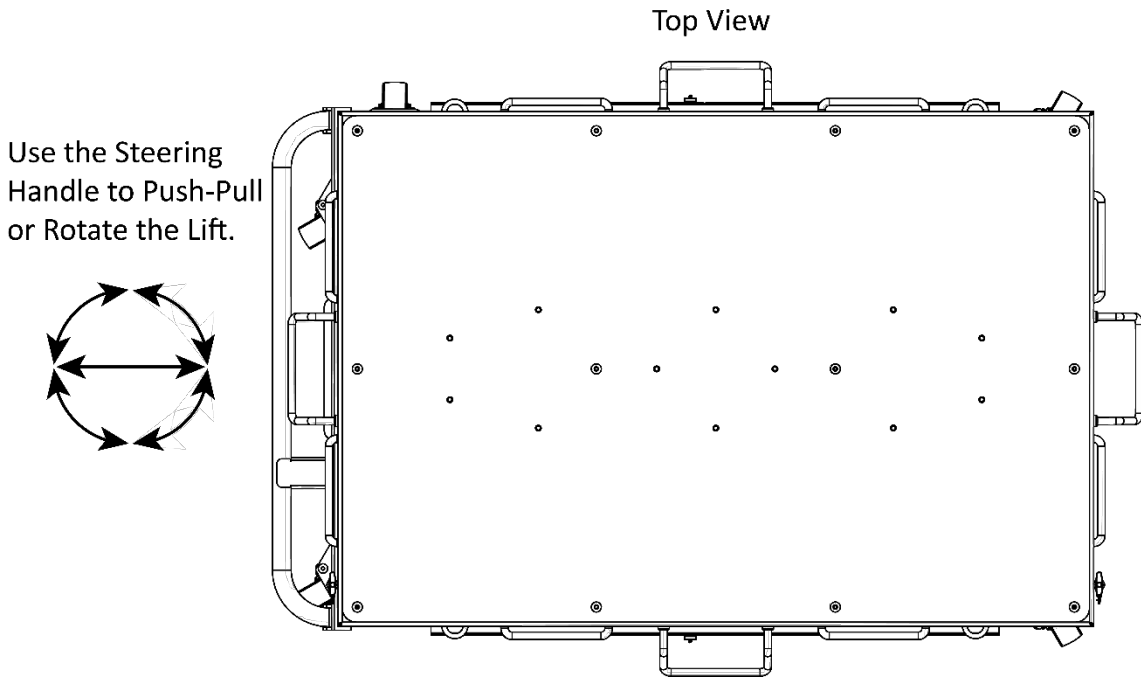

Figure not to scale, components removed for clarity.

Moving the MOBI-EVS

The steering handle is attached to the Lift's structure which rides on four zero-throw caster assemblies. This caster design allows easy push-pull and rotation of the entire Lift with minimal force required to move a given load. Refer to the figure below.



Locking Pins are provided to prevent the front Tri-Caster rotation when moving long distances. Insert or remove the locking pins as required.

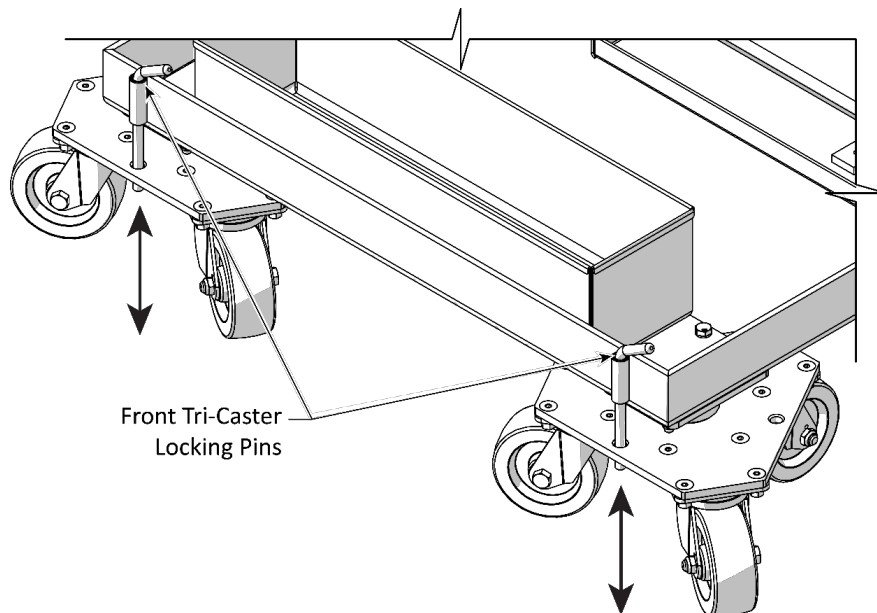

Adjusting the Top Deck

The top deck of the MOBI-EVS may be adjusted along its X (pitch) and Y (roll) axes using the four Leveling Jacks on the corners and to a much smaller degree about the Z (yaw) axis using the Slip Plate. These adjustments allow precise alignment and positioning of the load during installation or removal of vehicle components.

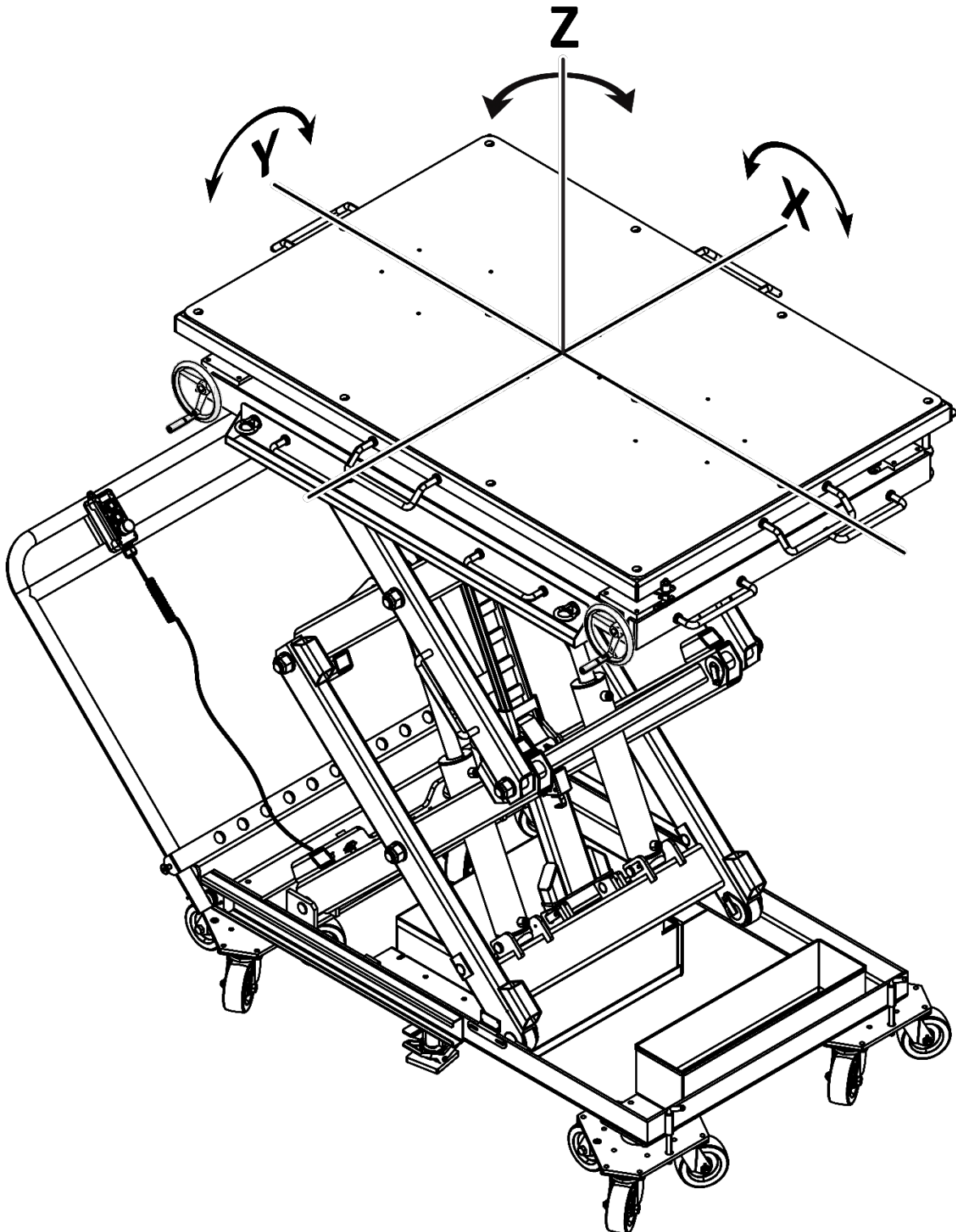

To Adjust the Top Deck using the Slip Plate:

The Slip Plate uses ball transfer load slides to allow small load position adjustments without repositioning the entire Lift. The Slip Plate allows a small amount of travel on either side of the centerline along both axes.

Remove the two Slip Plate Lock Pins and adjust the Slip Plate position using the handles placed along the perimeter of the plate. When work is complete, insert both Slip Plate Lock Pins into the Locking Brackets to secure the Slip Plate from movement while raising, lowering, or moving the Lift.

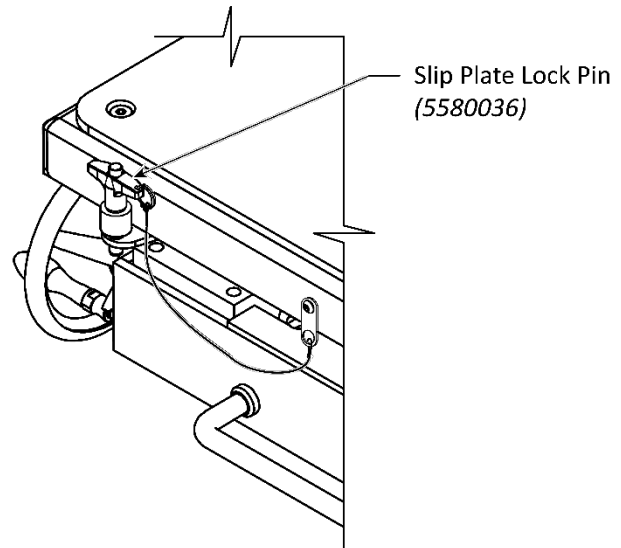

To adjust the Top Deck using the Leveling Jacks:

Rotate the Hand Wheel Jack adjustment on each corner of the top deck until the desired deck angle is achieved.

IMPORTANT!

Make small adjustments to the Leveling Jacks and gauge their effect on the Lift's stability and the desired load position. It is possible to adjust a load and create an unstable out of balance condition. Be aware of the load's center of gravity and its position in relation to the Lift's center of gravity.

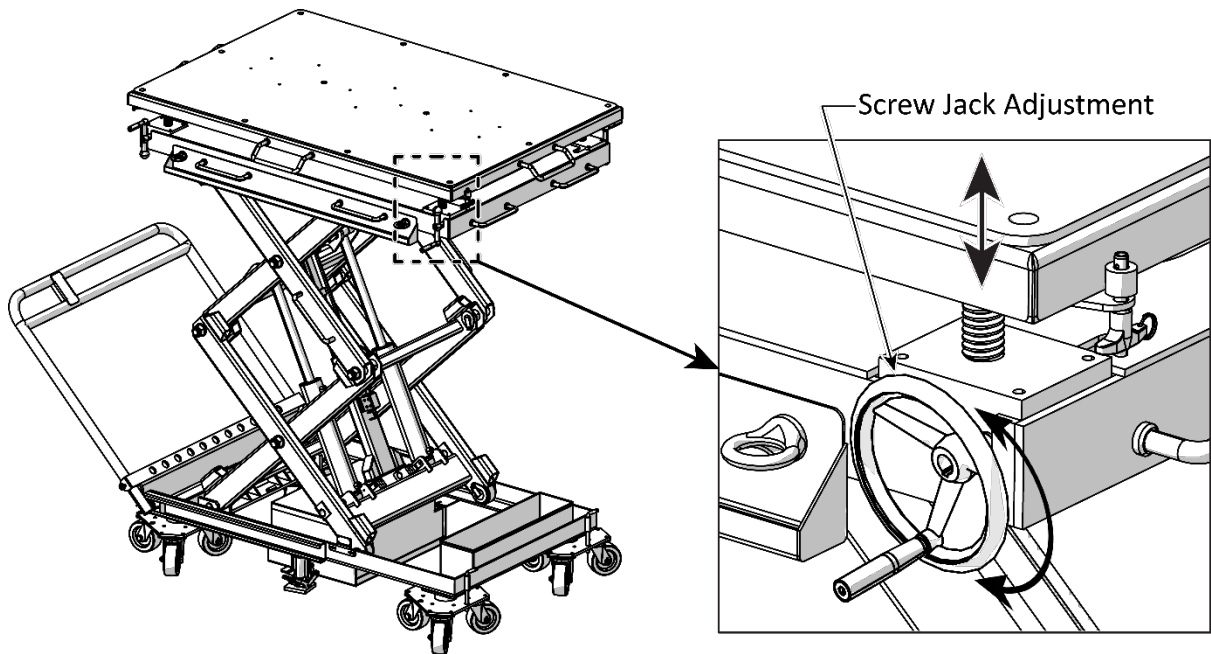

⚠ DANGER

Falling components may cause severe injury or death. Be aware of the effect changes to the top deck angle and position will have on the load's center of gravity. Always secure the load when lifting, lowering, or moving heavy components. Use appropriate tie downs to prevent load movement. Verify the Floor Locks are engaged, and the Lift is in a stable and safe condition prior to lifting, lowering, or moving any load.

⚠ DANGER **Tip Over Hazard! Place the load on the Lift centerline. Loads off the centerline of the Lift risk tipping or damaging the Lift and causing severe injury or damage.**



IMPORTANT! Keep the load's center of gravity on the centerline of the Lift. The load must be centered and evenly distributed across the top deck; do not rock the load while raised; remove heavy items that could cause an excessive weight shift.

✓ SAFE

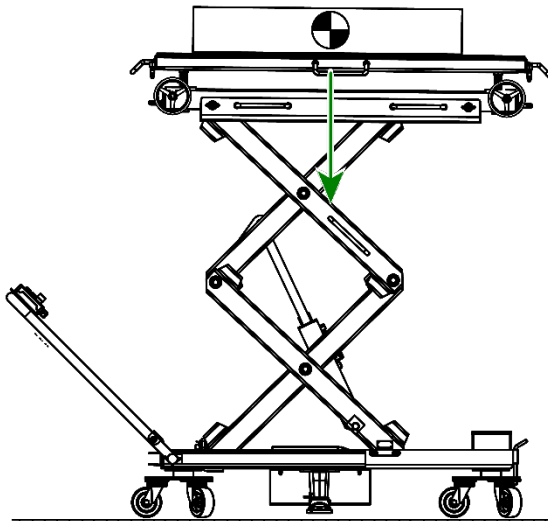

⚠ DANGER

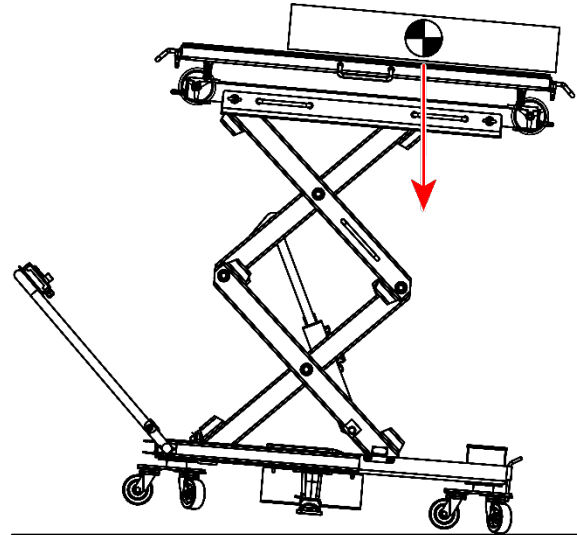

✓ SAFE

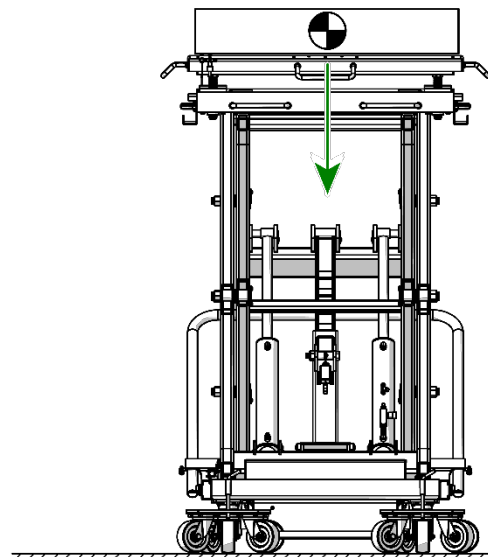

⚠ DANGER

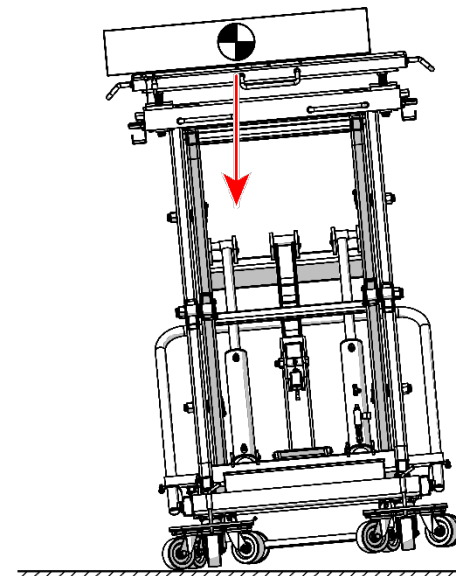

Not drawn to scale.

Using the Floor Locks

The Floor Locks will restrict the Lift's motion and provide additional support by engaging two rubber feet located in the center of both long sides of the Lift.

To engage the Floor Locks:

1. Move and orient the Lift as required for your application.
2. Use your foot to push down on the large pedal until the Floor Lock's rubber foot contacts the floor.
3. Repeat the same process on the other side of the Lift.

To disengage the Floor Locks:

1. Use your foot to press up on the small pedal. The Floor Lock will return to its disengaged position.
2. Repeat for the remaining Floor Lock on the opposite side of the Lift.

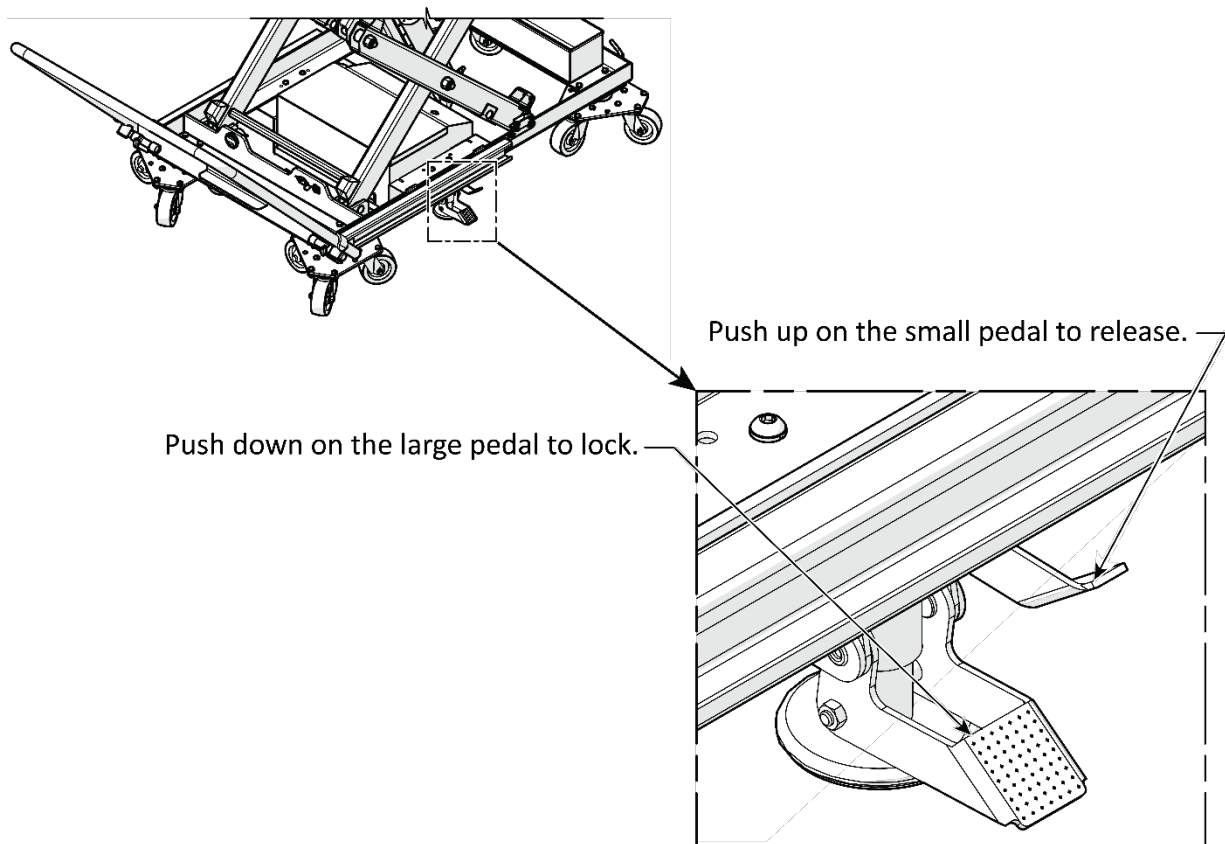

Not drawn to scale. Components removed for clarity.

About Safety Locks

When the lift mechanism rests on a Safety Lock the load is held without hydraulic pressure. Gravity and mechanical forces operate to hold the load in position. The MOBI-EVS incorporates a fail-safe locking system. Even if power is lost the safety lock catch will snap into place to ensure a safe Lift condition. The MOBI-EVS incorporates four safety lock positions allowing the operator to rest the lifting mechanism on a safety lock at a convenient height. The safety lock is located in the middle of the scissor lift mechanism and consists of a few simple components as detailed in the figure below.

The solenoid moves the safety catch into and out of a locking position. When the operator pushes the down button, the solenoid pulls the safety catch clear of the safety stops allowing the Lift's top deck to lower.

The solenoid CANNOT disengage the safety catch when the Lift is resting against a safety stop. Refer to the figure below.

To disengage the safety catch when resting against a safety stop:

1. Raise the top deck just a few inches by pressing the **Up** button.
2. Press the **Down** button and the safety catch should clear the safety stop allowing the top deck to lower.

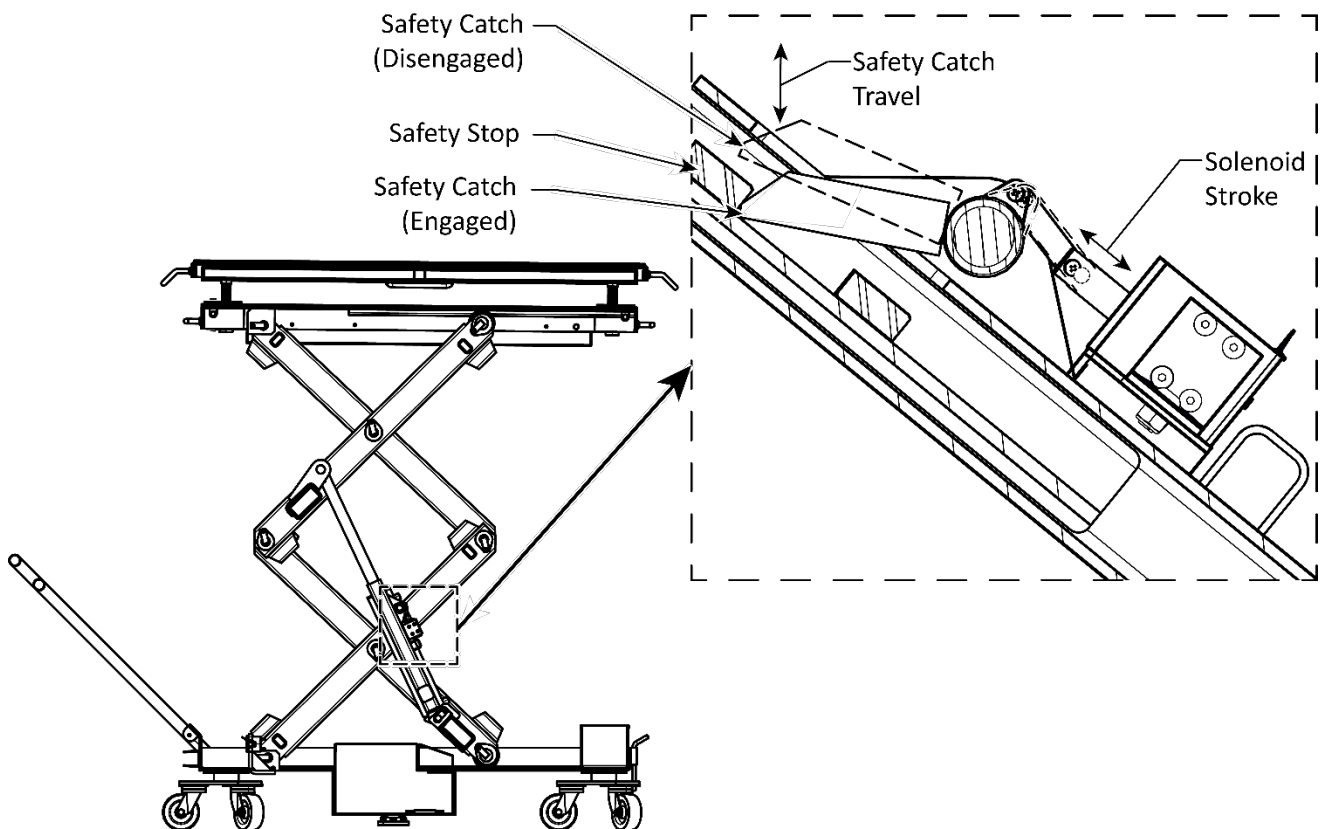

Figure not to scale. Partial cross section, components removed for clarity.

⚠ WARNING **Always leave the Lift engaged on one of the safety lock positions or lowered to its minimum height.** Although rare, it is possible for the hydraulic system to leak or become damaged, causing the top deck to slowly lower.

Learn to recognize the safety lock positions. Review the figures below to recognize when the top deck is locked and unlocked.

The Safety Lock is engaged when:

1. The safety catch is at rest in the lock channel and/or in contact with the side of a safety stop. Hydraulic force is **not required** to hold the top deck up when the safety lock is engaged.

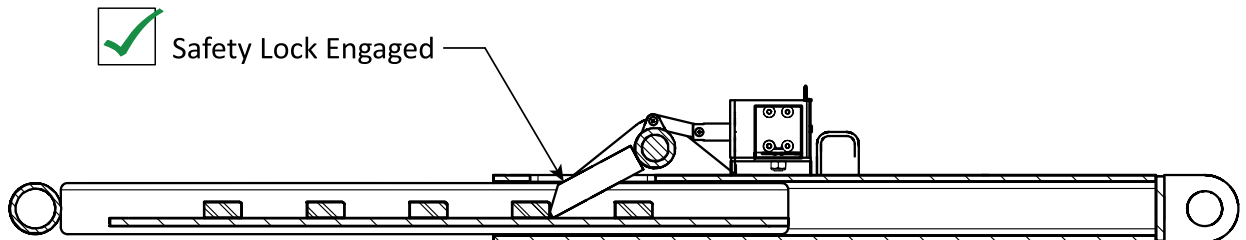

The Safety Lock is disengaged when:

1. The safety catch is no longer in contact with the lock channel or the side of a safety stop.
 2. The Lift will lower when pressing the Down button on the pendant.
- Hydraulic force **is required** to hold the top deck up when the safety lock is disengaged.

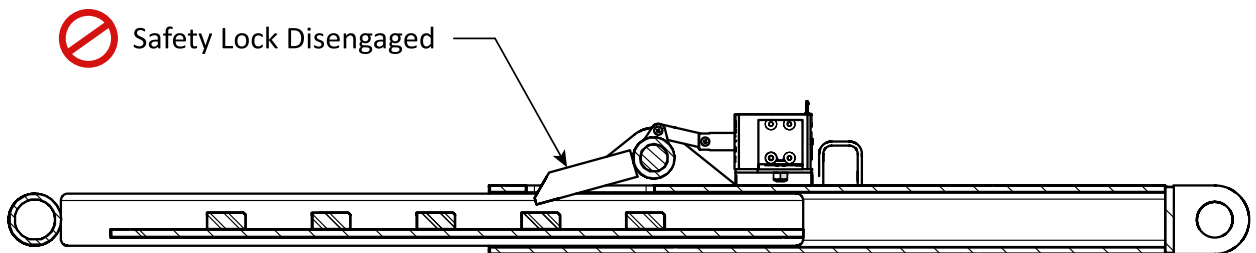

*Figures not to scale. Cross section view.
Components removed for clarity.*

⚠ WARNING **Always leave the Lift engaged on one of the safety lock positions or lowered to its minimum height.** Although rare, it is possible for the hydraulic system to leak or become damaged, causing the top deck to slowly lower.

Positioning and Raising the Lift

This section describes how to position and raise a load on the Lift.

To raise the Lift's Top Deck with a load:

1. Check the items listed in **Lift Operation Safety**. Resolve all safety issues before operating the Lift.
2. Plan the Lift. Some aspects of planning the Lift may include:
 - a. What is being lifted and its weight?
 - b. Where is the load's center of gravity? Position the center of gravity as close to the middle of the top deck as possible.
 - c. What are the dimensions, will it fit on the Lift?
 - d. What straps will be required to secure the load on the Lift?
 - e. What Personal Protective Equipment (PPE) is required?
 - f. What fasteners, connectors or components and tools are required to attach the load to the vehicle?
 - g. Pre-position components and tools so that they are readily available without interfering with the positioning of the Lift.
 - h. How many assistants will you need and what will be their tasks? Spotting, passing tools, etc.
 - i. How will the load position be adjusted, if necessary, to mate the component to the vehicle?
3. On the control pendant, rotate the **Stop Button** clockwise to provide power to the Lift.
4. Verify the Lift battery has a sufficient charge (>20%). If not, charge the battery prior to lifting the load.
5. Verify the top deck is fully lowered.
6. Verify the Floor Stops are engaged.
7. On the control pendant, press and hold the **Up** button to raise the Lift's top deck. Watch and note the speed at which the Lift rises. Adjust the **Flow Control Valve** as required to achieve the desired rate.
8. Determine the maximum top deck height and adjust the Limit Switch, if required. See **Adjust the Limit Switch**.
9. On the control pendant, press and hold the **Down** button until the Lift's top deck returns to its lowest rest position.
10. Press the **Stop Button** to remove power from the Lift.
11. Secure the load onto the Lift using tie down strap(s) or equivalent. Secure the tie down straps to the four eyebolts on the sides of the Lift.
12. Verify the load is secure and stable on the top deck and that there is a clear path to the Lifting site.
13. Disengage the Floor Stops.
14. Move the Lift by the smoothly pushing, pulling, or rotating the Steering Handle. Be aware of the weight and momentum of the Lift with its load. Move slowly and steadily. Do not make sudden turns that could shift the load's position on the Lift. Situate the Lift directly under the vehicle.

-
15. Walk around the Lift and verify there are no obstructions or any other issues that will interfere with raising the Lift's top deck.
 16. Engage and adjust the floor stops to ensure the Lift will not move while lifting or lowering.
 17. Verify the top deck is level and stable. Adjust the Jack Screws on each corner to level the top deck, if required.

 **WARNING** *Always* verify the Lift is resting firmly on the floor stops and all four Caster assemblies *prior* to raising or lowering a load.

18. The Lift operator should:
 - a. Position themselves to have an unobstructed view of the Lift and its immediate surroundings.
 - b. Make co-workers aware of the Lifting activity and to stay clear during the lift.
 - c. Never place his/her hands or a coworker's hands in a position to be pinched between the load and the vehicle.
19. On the control pendant, rotate the **Stop Button** clockwise to provide power to the Lift.
20. On the control pendant, press and hold the **Up** button to raise the Lift's top deck.
21. Carefully observe the top deck and load as it rises.

If the Lift or the load becomes unstable or moves unpredictably, release the **Up** button immediately. Lower the top deck, determine the cause, and correct the condition to bring the Lift into a safe condition.
22. When the top deck is at the desired height, release the **Up** button. The upward motion of the Lift's top deck may also be controlled by the Limit Switch.
23. Lower the Lift onto the nearest safety lock to leave the Lift in a safe condition.

Lowering the Lift

This section describes how to lower the Lift.

To lower the Lift:

1. Check the items listed in **Lift Operation Safety**. Resolve all safety issues before operating the Lift.
2. If the Lift is resting on a safety lock, press the **Up** button for a few seconds. Pressing **Up** allows the solenoid to release the safety catch clear of the safety stop.
3. Press and hold the **Down** button to lower the Lift's top deck.
4. Release the Down button when the top deck and the load are low enough to secure the load to the top deck.
5. Secure the load onto the Lift using tie down strap(s) or equivalent. Secure the tie down straps to the four eyebolts on the side of the Lift.
6. Verify the load is secure and stable on the top deck.
7. Press the **Down** button until the Lift is at its lowest rest position, then release.

 **WARNING** *Never move the Lift while the load is raised.* Lower the load completely before moving or storing the load.

8. When the load is safely lowered, check the load's stability on the Lift to verify it is safe to transport. Readjust the tie downs if required.
9. Disengage the floor stops.
10. Carefully move the Lift with its load out from under the Vehicle by pushing, pulling, or rotating the Steering Handle as required.

Adjust the Limit Switch

The maximum height of the Lift's top deck is mechanically constrained by the fully extended length of the Lift's hydraulic cylinders. The Limit Switch provides the ability to set a maximum lifting height which is lower than the Lift's mechanical maximum. The operator may set a maximum height that can prevent the Lift from colliding with obstructions and damaging the Lift or the Vehicle under repair.

The Limit Switch incorporates several adjustments. The first controls the switch's horizontal position (fore and aft) while the second controls the height of the Limit Switch arm and the last controls the arm angle. See figures to the right and below.

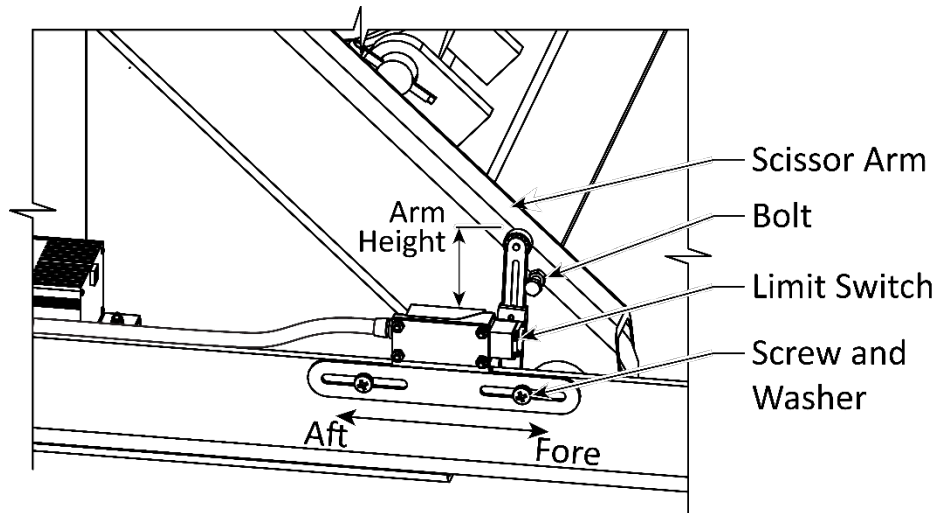

To adjust the Limit Switch:

1. Use a tape measure to determine the desired limit height to avoid obstructions.
2. Move and arrange the Lift to ensure that it will not strike any obstructions when raised.
3. Apply power to the Lift by rotating the **Stop Button** on the pendant clockwise.
4. Raise the Lift to the desired maximum height. Confirm with a tape measure.
5. Loosen the set screw then rotate the Limit Switch Arm until it contacts the Bolt on the Lift's Mechanism Arm continue rotating the arm until the Lift's top deck will no longer rise when you push the **Up** button on the pendant.
6. Additional adjustment is available by loosening the two screws that allow the Limit Switch to move fore and aft along the Lift.

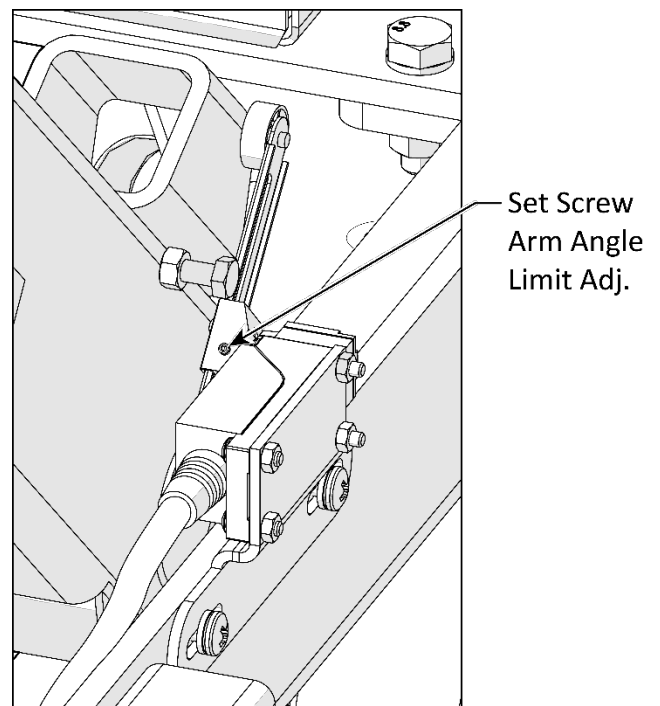

7. The length of the Limit Switch Arm may be adjusted to ensure contact with the bolt extending from the scissor arm.
8. Lower and raise the Lift while observing the height at which it stops. Adjust the Arm Angle, if required, until the Lift's top deck stops its ascent at the desired height.

Accessories

The MOBI-EVS Lifts feature sixteen recessed anchoring locations intended to accommodate a variety of accessories, modular fixtures, and adapters.

EVS Arm Kit

The optional Lift Arm Kit (5210454) is designed to attach easily to the Lift Deck in any of the 16 recessed anchoring locations on the top deck, providing a multitude of support options. The arm kit includes four telescoping lift arms, four adjustable height contact pads and four stackable adapters that provide configurable support for large, heavy, and awkward vehicle components. 600 lbs. (272 kg) maximum capacity each arm. Set of 4, see figure below.

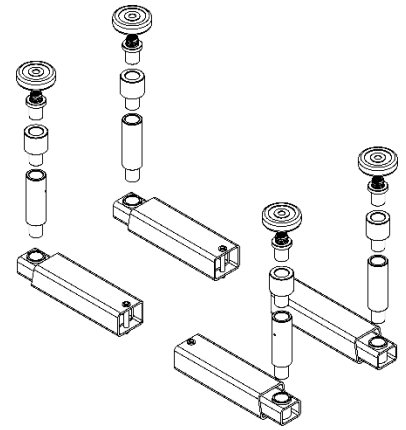

EVS Transjack Receiver Plate Kit

The Fixture Set with Adjustable Adapters (5210458) consists of four adjustable Accu-Point™ support fixtures creating a dynamic universal fitment of almost any vehicle. This assembly features independently adjustable and indexing locking arms that adapt to almost any late-model transmission, drivetrain, or vehicle sub-frame shape. The kit comes complete with four adjustable support fixtures, four adjustable height Contact Pads and four stackable Adapters. 600 lbs. (272 kg) capacity each fixture.

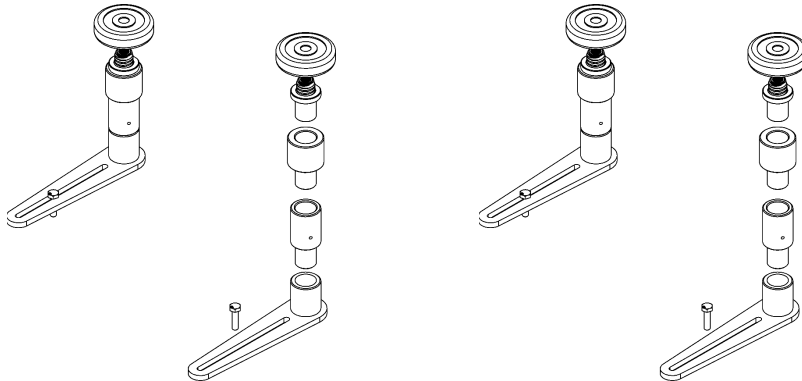

Transjack Deck Mount Kit

The Transjack Deck Mount Kit (5216234) features a center support pin that adapts to almost all late-model competitive transmission jack heads, drivetrain adapters and fuel tank supports on the market. See figure on the right.

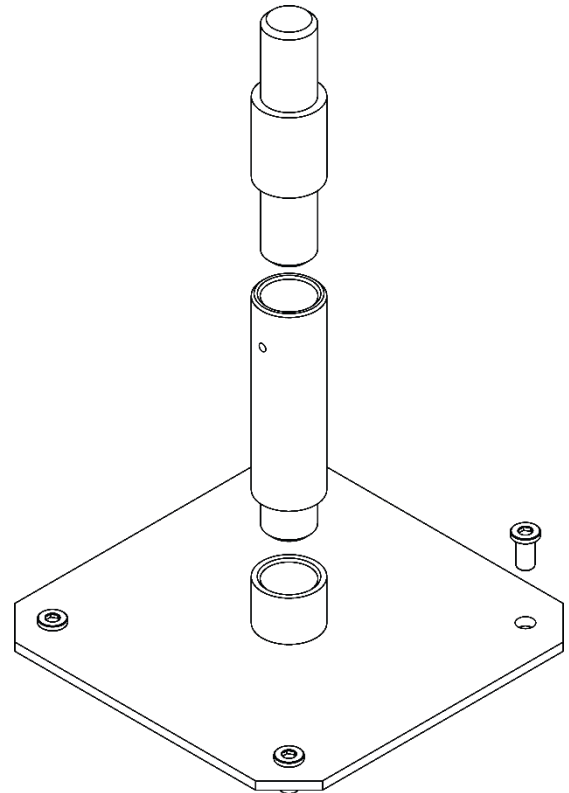

Multi-Point Support Assembly

The Multi-Point Adapter (5216205) safely supports large, heavy, and awkward vehicle components such as axles, fuel tanks, transfer cases, transmissions, bumpers, etc. Features adjustable telescoping arms and adjustable height contact pads for multi-configurable support. 800 lbs. capacity.

Important! The Multi-Point Support Assembly also requires a Transjack Deck Mount Assembly (5216234).

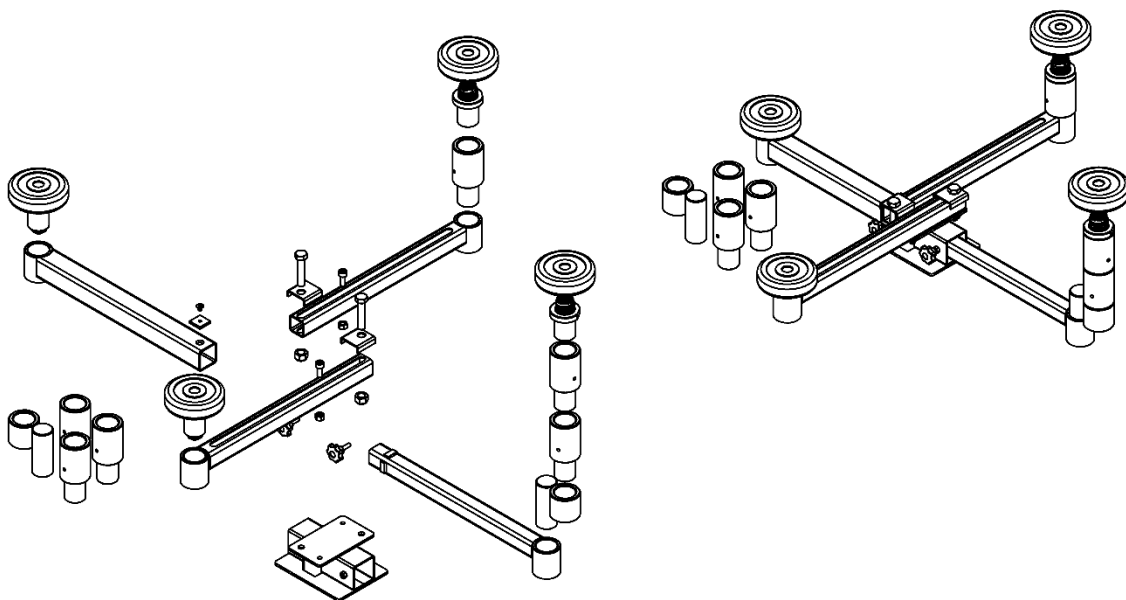

Maintenance

Preventative maintenance and safety is important for everyone operating the Lift. Improperly maintained equipment leads to premature failures, equipment damage and downtime. Unless stated otherwise, all maintenance may be performed by the owner/employer and does not require trained Lift Service Personnel.

 **DANGER** Before performing any maintenance, verify the Lift is completely disconnected from power and cannot be re-energized until all maintenance is complete.

 **DANGER** **Crushing hazard and pinch points.** Do not place any part of your body between the top deck and any moving part of the Lift unless visual confirmation is made that the safety lock is fully engaged, and/or that the Lift's downward motion is blocked by a Jack Stand, Forklift or other Load-Holding device that will prevent the Lift's downward movement.

To maintain your Lift:

- **Prior to every use:** Inspect Hoses for signs of damage or wear (areas of abrasion, bulging, cuts, cracks or leaking) any damaged hose can create a Lift failure. If a damaged Hose is found, do **NOT** operate the Lift. Take the Lift out of service until the Hose is replaced.
- **Daily:** Keep the Lift clean. Wipe up any liquid spills, clean and remove any dirt.
- **Daily:** Make a visual inspection of all moving parts. Check for damage or excessive wear. If you find damaged or worn parts, take the Lift out of service until they are replaced. Use only factory-approved replacement parts.
- **Weekly:** Check all controls to verify they are functioning normally.
- **Weekly:** Check all labels on the unit. Replace them if they are illegible or missing.
- **Monthly:** Lubricate all pivot points and axles. White Lithium Grease or similar is recommended.
- **Monthly:** Check the hydraulic fluid levels. Refill if low. Check the cleanliness of the Oil Filter.
- **Monthly:** Clean the battery. Dirt and grease can trap conductive material, increasing the rate of unintended discharge and shortening the life of the battery.
- **Monthly:** If the lift is experiencing long periods with little or no operation, on a monthly basis, operate the Lift from minimum to maximum height several times to maintain the cylinder seal's elasticity.
- **Every Three Months:** Check all electrical components for proper operation.

 **DANGER** You **must** always wear OSHA-approved (publication 3151) Personal Protective Equipment when servicing the battery: eye protection, leather gloves, steel-toed boots are **mandatory**.

- **Every Three Months:** Clean the battery terminals. See **Cleaning the Battery Terminals**.
- **After the first 3 months of operation:** Remove and replace the hydraulic fluid. Change the hydraulic fluid **every 24 months thereafter**. Dispose of used hydraulic fluid according to national and local environmental regulations. Contaminated hydraulic fluid will shorten the life of the cylinder seals.

 **WARNING** Do not operate your Lift if you find issues; instead, take the Lift out of service, then contact BendPak Technical Support. Visit bendpak.com/support, by email at support@bendpak.com, or by phone at **(800) 253-2363**, option 7, then 4.

Filling with Hydraulic Fluid

Follow the instructions in the [Initial Hydraulic Fluid Fill Procedure](#).

Bleeding the Hydraulic System

Bleeding the hydraulic system is **not required**. The system will Self-Bleed by raising and lowering the top deck several times with no load.

Checking the Battery Charge Level

The charge status of the Lift battery is displayed on the battery status indicator, located near the bottom of the Lift Frame (facing the steering handle). As battery power is consumed, the LED gauge will move downwards in 10% increments. See [Charging the Lift Battery](#).

⚠ CAUTION Do not allow the battery charge to drop **below** 20%, as this may affect the performance of the Lift; do not attempt to lift a load with a battery charge of 20% or less.

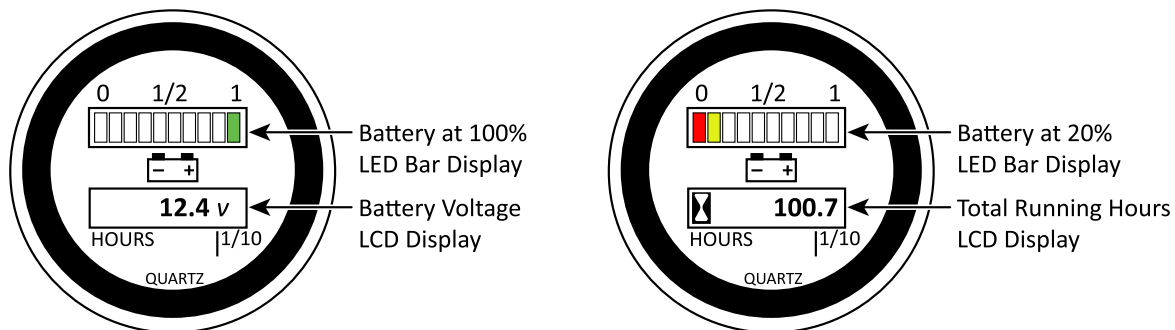

The battery status indicator LCD can display the current battery voltage or the total running hours.

To switch between total running hours and battery voltage briefly press the **S** button on the back of the indicator. When displaying battery voltage, a **V** is displayed to the right of the value and when displaying total running hours, an hourglass shape is displayed to the left of the value.

Charging the Lift Battery

When the battery level indicates approximately 20%, charge the battery. It typically requires 10 to 12 hours to reach a full charge. The battery charger is a fully automatic constant current charger, utilizing a micro-controller to monitor the charge state of the battery. The Charger includes protection against over-voltage, over-current, reversed polarity and short circuits.

⚠ DANGER Use of an incorrect charger for the Lift's battery may result in a battery explosion, severe injury, and property damage. Use only factory-approved replacement parts.

⚠ DANGER Never charge the battery in hazardous locations where potentially flammable or explosive gases are present.

To charge the Lift Battery:

1. The Control Pendant must be plugged in and the Stop button in the up "on" position to charge the battery. Verify the top deck is fully lowered, and the Lift is resting on its adjustable Floor Locks.
2. Use the supplied power cord (5324203) to connect the Charger to a 110 VAC outlet.

-
3. Charging is automatic and begins immediately.

IMPORTANT! **Charging and all Lift operation is disabled if the Stop Button is engaged. Rotate the Stop Button clockwise to apply power to the Lift.**

4. Monitor the battery status indicator and allow the Lift battery to come to a full (100%) charge.
5. After charging, disconnect the MOBI-EVS charging cord from the power receptacle and store.

Cleaning the Battery Terminals

Dirt and corrosion should be removed from the battery terminals regularly. Dirt can trap conductive materials which can eventually cause a loss of battery charge. Corrosion between metal connections in an electrical circuit will increase the electrical resistance resulting in the battery eventually losing its charge.

⚠ WARNING **Always wear complete eye and hand protective equipment;** avoid touching your eyes while working near a battery. Be careful to prevent corrosion and debris from coming into contact with your eyes.

Tools required:

- Old toothbrush
 - 1 Tbsp. Baking Soda
 - 1 Cup Water to mix with the baking soda.
 - Clean water to rinse
 - Apron or shop coat to protect clothing.
 - Rags to wipe the battery dry
 - Wrench to remove the battery cables.
 - Jack Stands or Sawhorses
1. Raise the Lift with no load and rest it on a safety lock. Use jack stands or sawhorses to ensure the top deck cannot lower while performing this service.
 2. Remove the cover protecting the battery and power unit.
 3. Inspect the battery. If the battery case is cracked or swollen, **do not clean the battery, replace it!**
 4. If the battery is in good condition, use a wrench to remove the battery cables from the terminals. Exercise care not to short the wrench against any metal part of the Lift and a battery terminal. (Remove the negative cable first. When reinstalling, install the negative cable last.)
 5. Create a solution of clean water and baking soda, one tablespoon of baking soda into one cup of clean water. Stir to mix the solution.
 6. Wear a shop coat to protect clothing. Wet the toothbrush in the baking soda solution, then scrub the Terminals and the Connectors with the brush and rags to remove corrosion and dirt.
 7. Flush carefully with a small amount of water. Do not allow water to short between the battery terminals. Wipe the terminals, connectors, and battery until clean and dry using cloth rags.
 8. Connect cables in this order; the red cable to the positive (+) battery terminal and then the black cable to the negative (-) battery terminal.
 9. Remove the jack stands or sawhorses and discard the toothbrush. Clean the floor and surrounding area.

Lubrication

- **Daily** – Keep the scissor roller paths clean and clear of debris. Refer to the figure below.
- **Monthly** – Lubricate all scissor pivot points on **both sides** of the scissor mechanism, rollers, axles and steering handle slides with a general purpose white lithium grease spray.
- **As Required** – Lubricate the acme thread on all Leveling Jacks with #2 Heavy Duty Lithium Grease.

Lubricate both Steering Handle Slides.

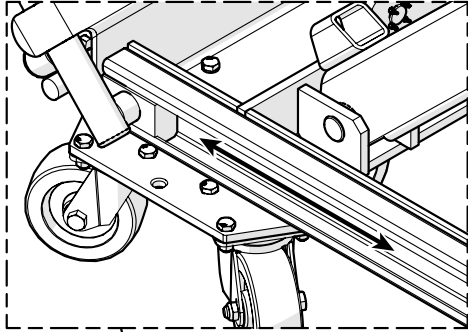

Lubricate all pivot points.

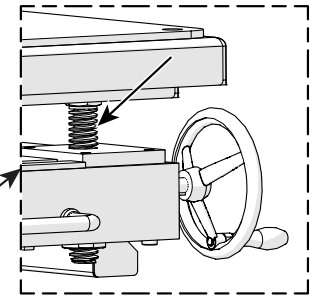
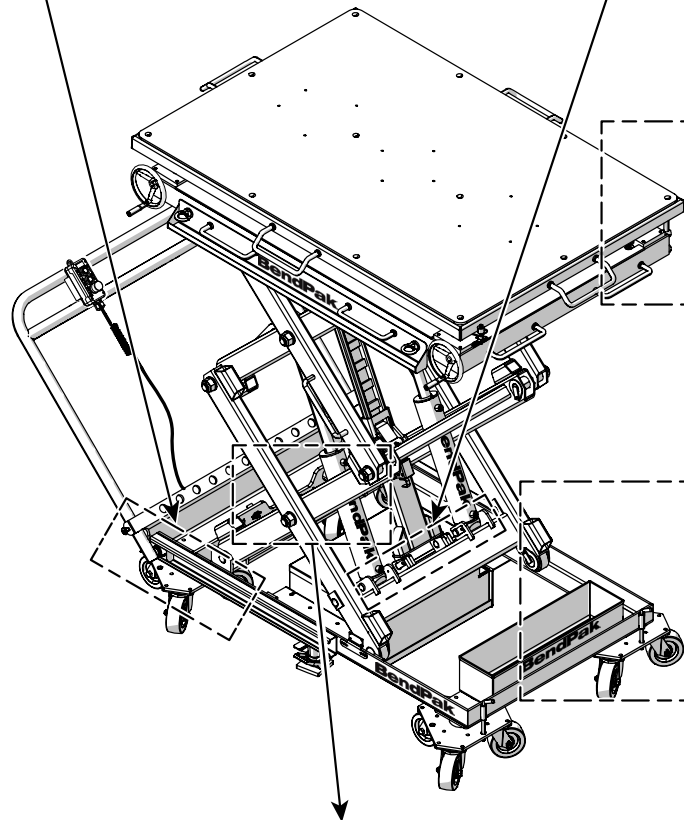
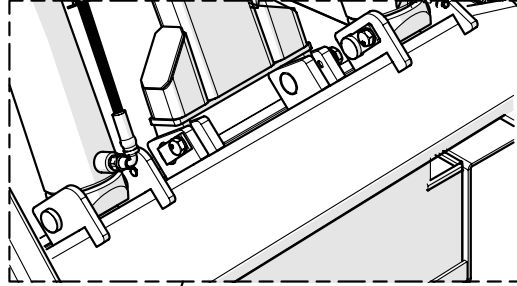

Lubricate the Acme Thread on all four Screw Jacks.

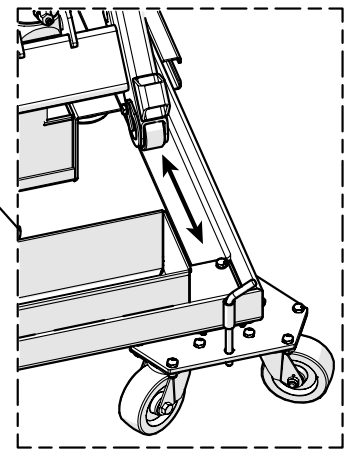

Keep both scissor roller paths clean and free of debris.

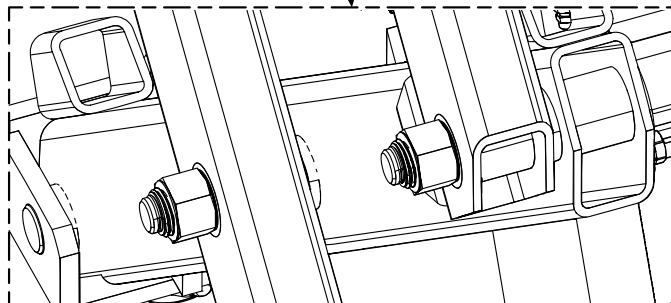

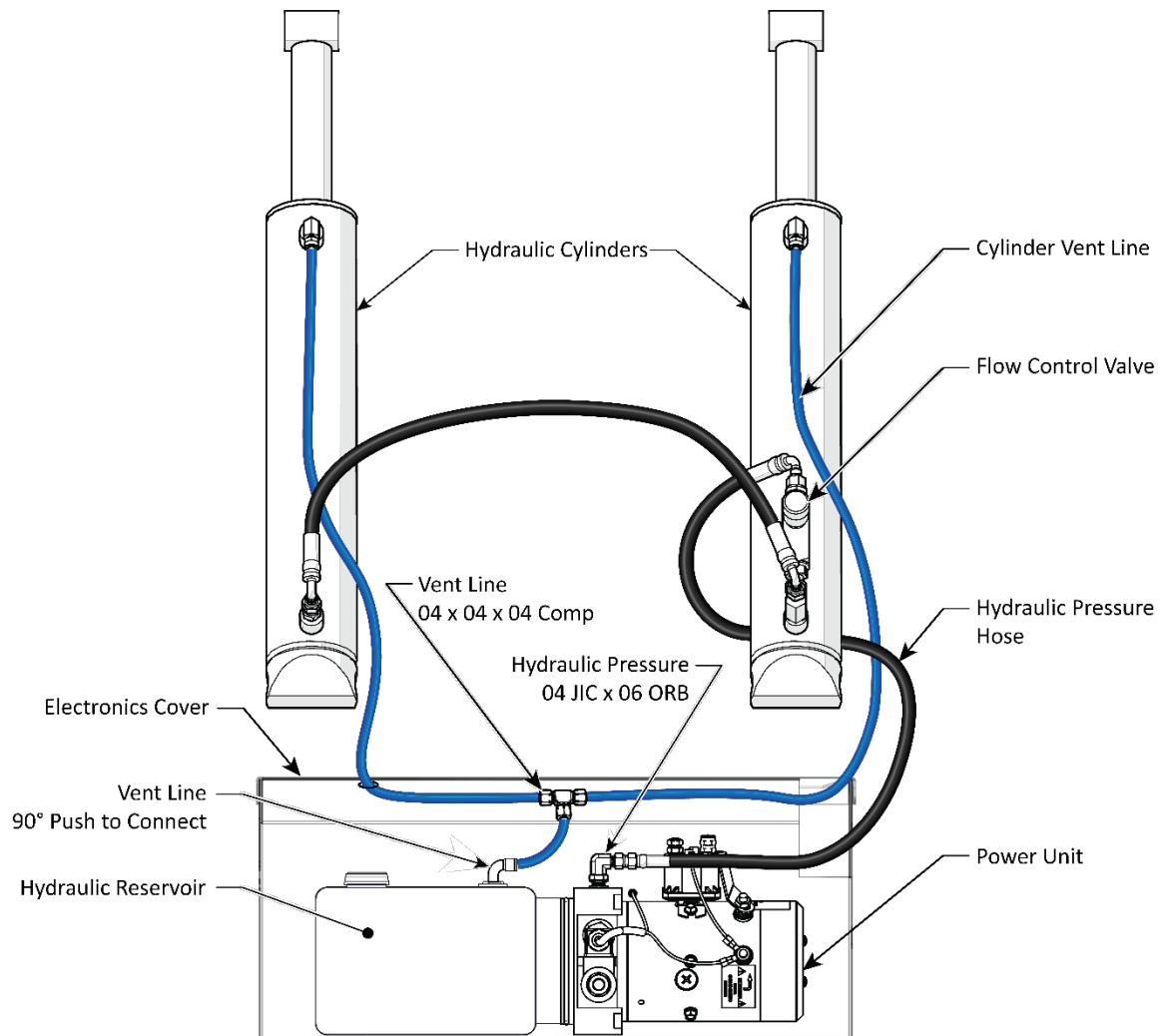

Lubricate all mechanical Scissor, Pivot and Roller

Hydraulic Pressure and Cylinder Vent Line Diagram

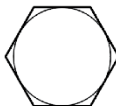
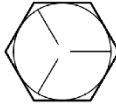
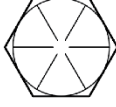

Fastener Torque Chart

FASTENER TORQUE CHART											
Bolt Size (SAE)	Bolt Grade (SAE)	SAE Grade 0-1-2	SAE Grade 5	SAE Grade 8	Socket Head Cap Screw SAE Grade	Tightening Torque			Tightening Torque		
						Lubricated (ft.-lbs)	Zinc Plated (ft.-lbs)	Plain & Dry (ft.-lbs)	Lubricated (ft.-lbs)	Zinc Plated (ft.-lbs)	Plain & Dry (ft.-lbs)
	Bolt Class (Metric)	Metric Class 4.6	Metric Class 8.8	Metric Class 10.9	Metric Class 12.9						
											
		4.6	8.8	10.9	12.9						
Bolt Size (SAE)	Bolt Size (Metric)	Tightening Torque			Tightening Torque			Tightening Torque			
		Lubricated (ft.-lbs)	Zinc Plated (ft.-lbs)	Plain & Dry (ft.-lbs)	Lubricated (ft.-lbs)	Zinc Plated (ft.-lbs)	Plain & Dry (ft.-lbs)	Lubricated (ft.-lbs)	Zinc Plated (ft.-lbs)	Plain & Dry (ft.-lbs)	
1/4-20	M6 x1.0	2.3	2.6	3.0	5.8	6.6	7.7	8.3	9.4	11.1	
5/16-18	M8 x 1.25	3.8	4.3	5.0	9.7	11.0	13.0	13.9	15.8	18.5	
3/8-16	M10 x 1.50	10.8	12.3	14.4	27.9	31.6	37.2	39.9	45.2	53.2	
7/16-14	N/A	24.0	27	30.0	35.0	42	50.0	55.0	59	70.0	
1/2-13	M12 x 1.75	18.9	21.4	25.2	48.7	55.1	64.9	69.6	78.9	92.8	
9/16-12	M14 x 2.00	30.2	34.2	40.2	77.8	88.1	103.7	111.3	126.1	148.4	
5/8-11	M16 x 2.00	47	53	62	121	137	161	173	196	230	
3/4-10	M18 x 2.50	65	73	86	167	189	222	239	270	318	
7/8-9	M22 x 2.50	136	155	182	320	365	430	460	515	600	

WARNING! Prior to installation, inspect all accompanying manuals, parts lists and catalogs to ensure you have all the necessary parts. Identify all fasteners and their proper torque settings as illustrated on this chart. Proper torquing practices cannot be over emphasized. Torque values are provided as a convenient method of achieving correct pre-loading of highly stressed fasteners. If the fasteners are not properly plated, the fastener threads are not clean and free of deformation, or are not properly lubricated, the correct fastener pre-load will not be achieved even though the given torque value is reached. For this reason, it is critical that all fasteners be inspected for proper plating, thread form and correctly lubricated prior to torquing. Failure to verify a fastener's serviceability or to correctly lubricate the fastener prior to assembly and torquing will result in the fastener not being properly pre-loaded and subsequent failure of the fastener may occur. The torque values can only be achieved if the nut (or tapped hole) has a proof load greater than or equal to the bolt's minimum ultimate tensile strength. Clamp loads estimated as 75% of proof load for specified bolts. Torque values are listed in foot-pounds. Torque wrenches should be calibrated on an annual basis. Never use an impact driver on a torque multiplier.

Disposing of Used Hydraulic Fluid

Used hydraulic fluid cannot be disposed of by dropping it into the trash or dumping into the street. Hydraulic Fluid has toxic ingredients that are harmful to the environment. Either recycle the hydraulic fluid or drop it off at a hazardous waste collection facility. Dirty or contaminated fluid must be treated as hazardous waste. Rags and/or granular absorbents that have soaked up hydraulic fluid should be treated like hazardous waste and be disposed of at a hazardous waste collection facility.

To find an appropriate facility:

- Local automotive parts stores, auto care facilities, or automobile dealerships may accept fluid for recycling or, in some cases, for disposal. Contact them for more information.
- Cities, counties, and states often support both recycling facilities and hazardous waste collection facilities. Contact them to see if and where they have these programs.

If you are unable to find an appropriate facility, the website [earth911.com](https://www.earth911.com) has resources that may be of help.

MOBI-EVS Lift Disposal - End of Service Life

Once your Lift has reached the end of its service life it must be disposed of properly. Metal recyclers will be able to advise on methods and costs to remove the Lift and will *reuse* the materials, diverting them from landfills. The best option is to contact a metal recycling center and discuss the size and weight of the Lift to determine if the facility can deconstruct and recover the usable components and metals.

The hydraulic cylinders, hoses, fittings, and the power unit itself must be disposed of in accordance with current national, state, and local regulations governing the use and disposal of hazardous materials. These components and any used hydraulic fluid *must not* be disposed of by dropping it into the trash or dumping it into the street. The hydraulic fluid contains toxic ingredients that are harmful to the environment.

These components and the hydraulic fluid are required to be recycled or must be delivered to a hazardous waste collection facility.

If you have large amounts of hydraulic fluid, consider contacting a commercial waste disposal company. In all cases, the best approach is to find an appropriate facility and contact them — in advance — to ask them: what kinds of fluids and materials they accept, what kind of containers it must be in, what hours they are open, their location, and any other information specific to their facility.

If you are unable to find an appropriate facility, the website [earth911.com](https://www.earth911.com) has resources that may be of assistance.

Troubleshooting

This section describes common troubleshooting issues for the MOBI-EVS.

Note: *If your Lift is not functioning correctly, you must take it out of service until it is repaired.*

Important: All repair work **must** be completed and inspected by qualified personnel.

Issue	Action to Take
The Motor does not run.	Check the battery voltage 12 to 14.7VDC with no load. Circuit breaker tripped? Verify the Limit Switch is not engaged. Verify the Limit Switch is not damaged or inoperative. Verify power is supplied to the Pendant Control. Verify power is supplied from the Pendant Control to the solenoid when the down button is pressed.
Pump runs, but top deck does not move up or down.	Verify the Lift is not overloaded. Verify there is sufficient hydraulic fluid in the reservoir. Verify the Limit Switch is not damaged or engaged. Inspect for hydraulic leaks. Inspect fluid for dirt or other contamination.
Top Deck does not raise to its full height.	Verify there is sufficient hydraulic fluid in the reservoir. Verify the Limit Switch is not engaged or damaged.
Top Deck is slowly lowering on its own.	Replace the lowering valve. Clean the lowering valve. Inspect for low hydraulic fluid. Inspect for pinched, kinked, or abraded hydraulic hoses. Inspect for hydraulic leaks.
Battery does not charge.	Check battery for dirty or corroded terminals. Replace the battery. Replace the battery charger. Check for damaged wiring. Check for damaged connectors.
Hydraulic Fluid is old or dirty.	Replace the dirty fluid with clean, approved hydraulic fluids, such as Dexron III, Dexron VI, Mercon V, Mercon LV, Shell Tellus S4 / S3 / S2, or comparable.

Electrical and Charging System Troubleshooting

Issue	Action to Take
Battery status indicator gives a blank LED and LCD display.	Look for damaged wiring. Repair/Replace. Incorrect Connector wiring. Repair/Replace Check for damaged connectors. Verify battery voltage is 12 to 14.7 VDC with no load.
Timer Hourglass icon does not flash after opening function.	Look for damaged wiring. Verify the connector is wired correctly.
No change on voltage LED bar display	Battery parameters incorrectly programmed into Indicator. 200-second delay not completed.
Slow or faded LCD display.	Exposure to excessive heat or cold. Return the display to normal operating temperatures.
Battery status indicator only displays total running hours.	Briefly push the S button on the back of the battery status indicator. The indicator should display battery voltage with a V after the value. If the Display continues to only display hours, then contact BendPak Technical Service.

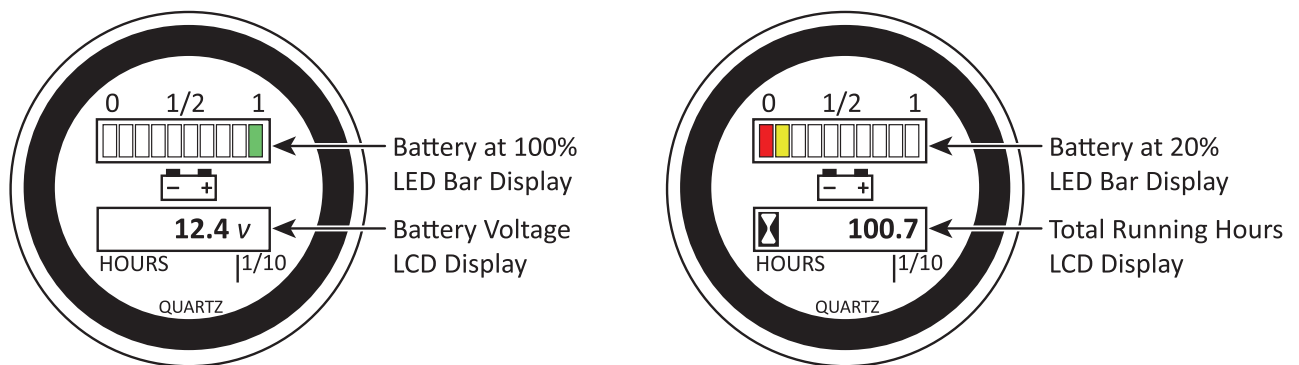

Connector Pin Assignments

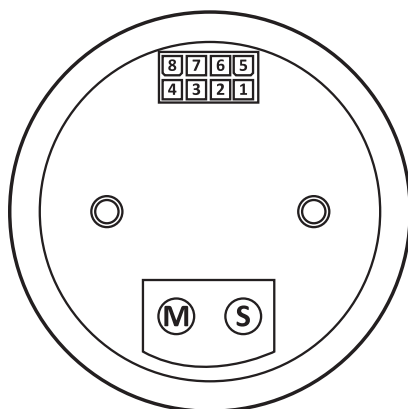

8	7	6	5
4	3	2	1

Pin	Function	Pin	Function
1	No connection	5	Connect to (-) VDC Negative
2	Connect to (+)12VDC	6	Connect to (+)12 VDC
3	No connection	7	Connect to (+)12 VDC
4	No connection	8	No connection

If you continue to have problems with your Lift, take the Lift out of service, then contact your dealer, visit bendpak.com/support, by email at support@bendpak.com, or by phone at (800) 253-2363, option 7 then 4. Online chat is also available at www.bendpak.com click the chat icon.



Wiring Diagram

SYMBOL	DESCRIPTION
QF1	AUTOMATIC RESET BREAKER 250A
XL	DC 12V LIMITER
L1	SAFETY SOLENOID
KM1	START CONTACTOR
SB1	SWITCH, EMERGENCY STOP
SB2	SWITCH, UP
SB3	SWITCH, DOWN
SQ	LIMIT SWITCH
YV	ELECTROMAGNETIC COIL RELAY, 4-POLE, DBL. THROW
KA	RELAY, 4-POLE, DBL. THROW

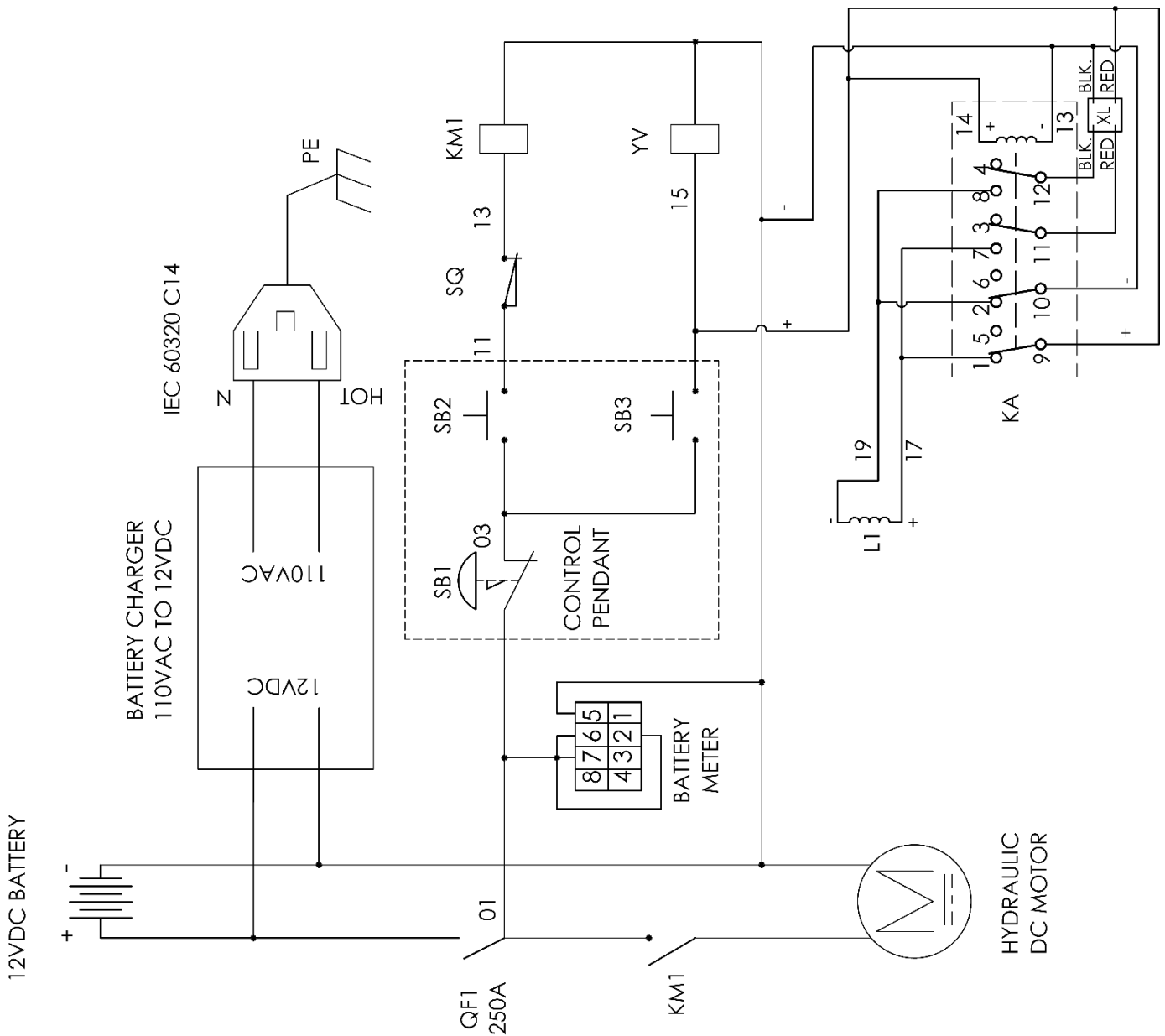

Labels

A

BendPak

PN 5905884

B

⚠ WARNING

THIS MACHINE MUST ONLY BE OPERATED BY PROPERLY TRAINED PERSONNEL. DO NOT USE THIS LIFT UNTIL IT HAS BEEN INSPECTED AND IS APPROVED FOR OPERATION.

IMPROPER USE OF THIS MACHINE COULD CAUSE SERIOUS INJURY OR DEATH.

- **DO NOT** operate this machine unless you have been properly trained by an authorized and qualified person as described in the BendPak Setup and Operation Manual. Your training includes reading and understanding the safety, operation, and maintenance instructions in the manufacturer's manuals, knowing your employer's work rules and applicable governmental regulations.
- **FOLLOW** the instructions in the Operating Manual and applicable standards for daily, monthly, and annual inspections. These may be obtained from your authorized equipment dealer or BendPak.
- **DO NOT** add or replace parts (e.g., batteries, wheels, power units) with items of different weights, specifications, or positions on the Lift. These changes can shift the Lift's Center of Gravity and compromise the stability of the Lift.
- **DO NOT** modify or change the machine without written approval from the manufacturer.
- Operate this machine with extreme caution. **STOP** all operation if malfunction occurs.

CAUTION: Use of an incorrect charger for the Lift battery can result in battery explosion, serious injury and property damage. PN 5906121

PN 5906121

C

⚠ ATTENTION

MAXIMUM LIFTING CAPACITY
CAPACITÉ DE LEVAGE MAXIMUM

3,000 Lbs.
1,361 Kg.

PN 5905899

PN 5905899 **ONLY FOR EVS3000**

D

⚠ ATTENTION

MAXIMUM LIFTING CAPACITY
CAPACITÉ DE LEVAGE MAXIMUM

4,500 Lbs.
2,041 Kg.

PN 5905900

PN 5905900 **ONLY FOR EVS4500**

F

⚠ DANGER

NEVER ADJUST THE LEVELING JACK HANDWHEEL WHEN THE SLIP PLATE IS UNPINNED AND FREE TO MOVE.



PN 5905919

PN 5905919

E



<p>⚠ DANGER</p> <p>KEEP HANDS CLEAR OF ALL PINCH POINTS.</p> 	<p>⚠ WARNING</p> <p>DO NOT go under a raised lift platform or attempt any lift maintenance until load is removed and visual confirmation is made that the safety lock support is fully deployed.</p> 	<p>⚠ CAUTION</p> <p>ALWAYS follow lockout/tagout procedures when doing service work. ALWAYS make sure lift is secure and safety lock is deployed to prevent it from dropping.</p> 	<p>⚠ CAUTION</p> <p>Protective eyewear, face shield and gloves MUST be worn at all times when servicing or checking batteries.</p>  <p>PN 5906122</p>
--	--	--	--

PN 5906122

G

⚠ DANGER

Make sure to **READ** and understand all instructions and safety precautions as outlined in the manufacturer's operation manual prior to using this equipment. Failure to follow **ALL** instructions can result in bodily harm or **DEATH** to operator and/or bystanders.

 <p>KEEP hands and feet clear at all times from moving machinery.</p>	 <p>DO NOT go under a raised lift platform until load is removed and lift is securely blocked in raised position with an upright support stand.</p>	 <p>DO NOT stand, sit, or ride on the lift platform.</p> <p>PN 5906124</p>
---	---	--

PN 5906124

H

⚠ WARNING

ALWAYS verify the floor locks are engaged and in firm contact with the floor prior to raising or lowering the lift platform.

NEVER move the Lift across a floor when the platform is elevated. Minor adjustments (less than 12") when attempting to align battery packs or power train components are acceptable. **ALWAYS** make sure the lift platform is lowered completely, prior to rolling the lift system across any floor.



PN 5906123

PN 5906123

Optional Arm Kit Label

I

⚠ WARNING	⚠ ATTENTION
<p>Read the entire contents of the manual that accompanied this product prior to use. Failure to follow the instructions can result in serious injury or death.</p> <ul style="list-style-type: none"> • Maximum load capacity for these auxiliary arms is 600 lbs. (272 kg) each or 2,400 lbs. (1,088 kg) per set of four. • Overloading the arms can damage equipment and/or result in serious bodily injury or death. • ALWAYS secure the load with safety chains or straps before lowering or moving the load. 	<p>Lisez l'intégralité du contenu du manuel qui accompagne ce produit avant de l'utiliser. Le non-respect des instructions peut entraîner des blessures graves ou la mort.</p> <ul style="list-style-type: none"> • La capacité de charge maximale de ces bras auxiliaires est de 272 kg chacun ou 1088 kg par jeu de quatre. • La surcharge des bras peut endommager l'équipement et/ou entraîner des blessures corporelles graves ou la mort. • TOUJOURS sécuriser la charge avec des chaînes ou des sangles de sécurité avant d'abaisser ou de déplacer la charge.

PN 5906063



J

BP BendPak Santa Paula, CA USA
www.bendpak.com

MODEL NUMBER
DESCRIPTION
LIFT CAPACITY
DATE CODE
SERIAL NUMBER
UPC

DANGER!
Disconnect Power Before Servicing

CE EAC

MADE IN CHINA WARRANTY VOID IF DATA PLATE IS REMOVED PN 5905150

PN 5905150

K



PN 5906044

L

CALIFORNIA PROPOSITION 65

⚠ WARNING ⚠

WARNING! This product can expose you to chemicals including styrene and vinyl chloride which are on the list of over 900 chemicals identified by the State of California to cause cancer, birth defects or reproductive harm. ALWAYS use this product in accordance with the manufacturer's instructions. For more information, go to www.p65warnings.ca.gov.

PN 5905775

PN 5905775

M



PN 5930609

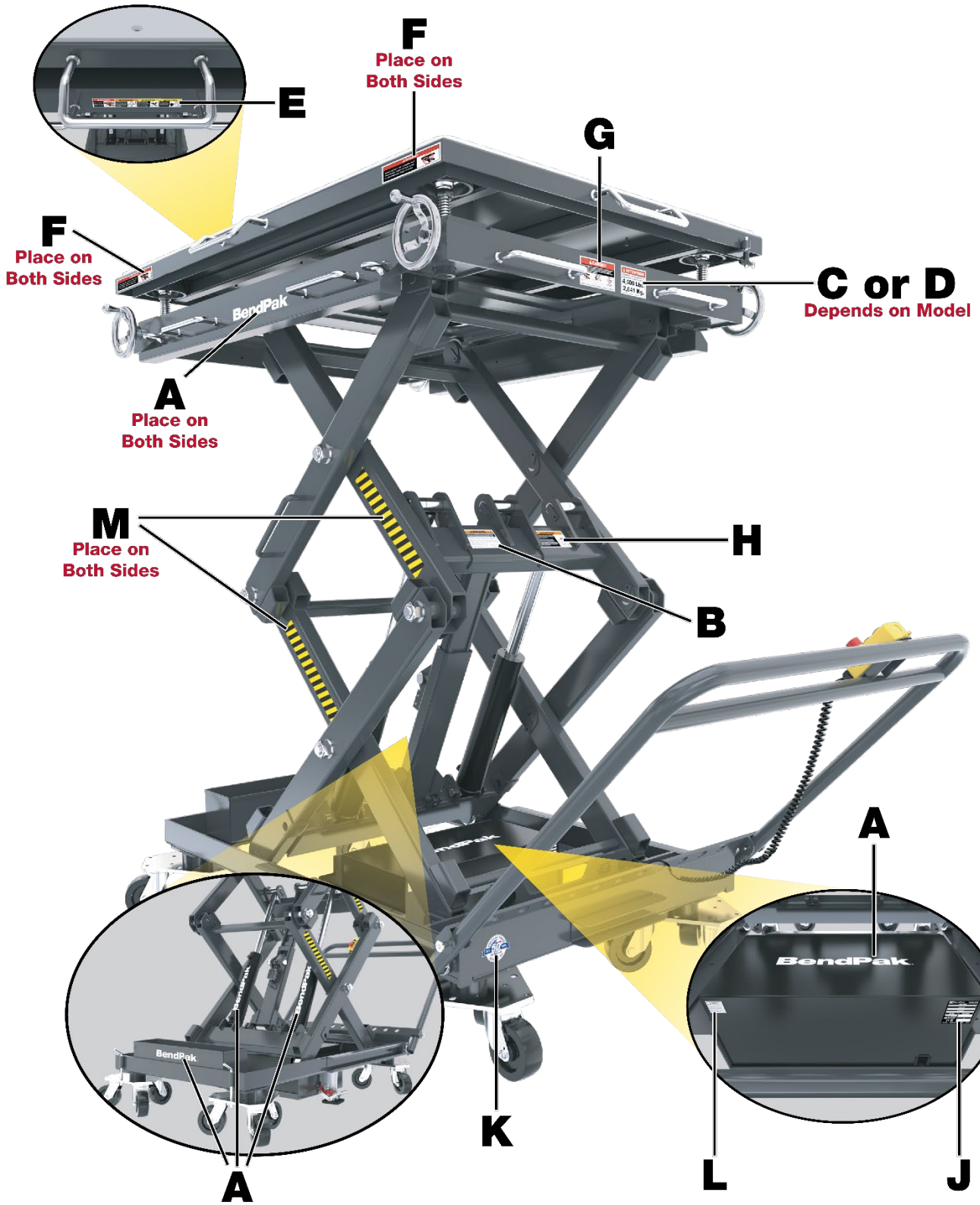

Parts Drawings

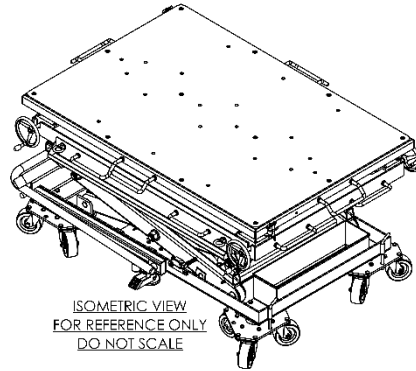
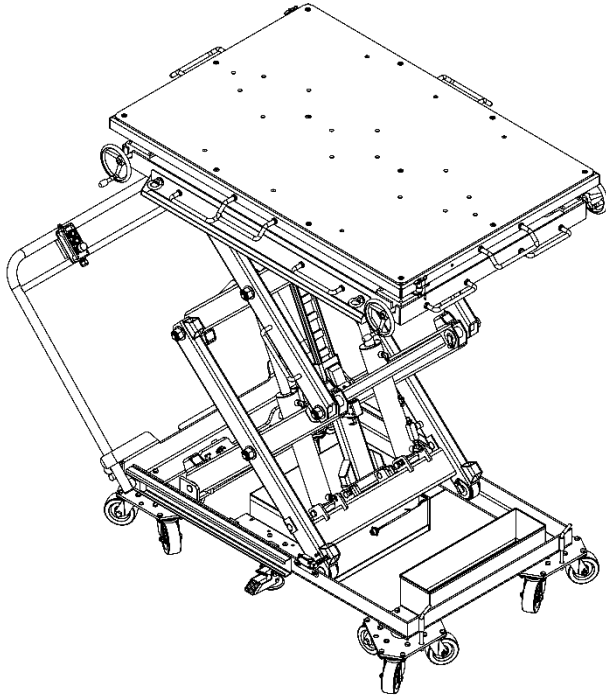

ITEM NO	PART NUMBER	DESCRIPTION	QTY	REV
1	5245287	EVS3000/4500 SUPERSTRUCTURE	1	E
2	5250389	EVS PARTS BOX	1	A
3	5210386	EVS ELECTRONICS COVER ASSEMBLY	1	E
4	5585924	EVS POWER UNIT, 12V DC, 1500 PSI PRV	1	-
5	5715046	POWER UNIT VIBRATION DAMPENER 132mm x 32mm	1	A
6	5530488	BHSS 3/8-16" x 1 3/8" FT, GR 8	2	-
7	5545130	WASHER 3/8" SL, GR 8	2	-
8	5550103	FTG ELB-04 JIC-06 ORB	1	-

3D 1:1 SCALE DRAWING

DRAWN: [Signature] NAME: [Signature] DATE: 08/08/2023

CHECKED: [Signature]

DIMENSIONS ARE IN: MILL

THIRD ANGLE PROJECTION

PROPRIETARY AND CONFIDENTIAL
THIS DOCUMENT CONTAINS THE PROPRIETARY AND CONFIDENTIAL INFORMATION OF BENDPAK INC. ANY REPRODUCTION OR DISTRIBUTION OF THIS DOCUMENT WITHOUT THE WRITTEN PERMISSION OF BENDPAK INC. IS STRICTLY PROHIBITED.

BP BendPak
30440 AGOURA RD.
AGOURA HILLS, CA 91301

TITLE: EVS3000 PRODUCTION LIFT VER C

SIZE DWG. NO. REV
A 5260703 E

SCALE: 1:16 SHEET 1 OF 4

- NOTE: UNLESS OTHERWISE SPECIFIED**
1. REFER TO MODEL FOR ADDITIONAL INFORMATION
 2. SEE COLORS & GRAPHICS FOR LABEL PLACEMENT
 3. ASSEMBLE ITEMS AS SHOWN
 4. SEE SHIPPING INSTRUCTIONS FOR FINAL PACKAGING

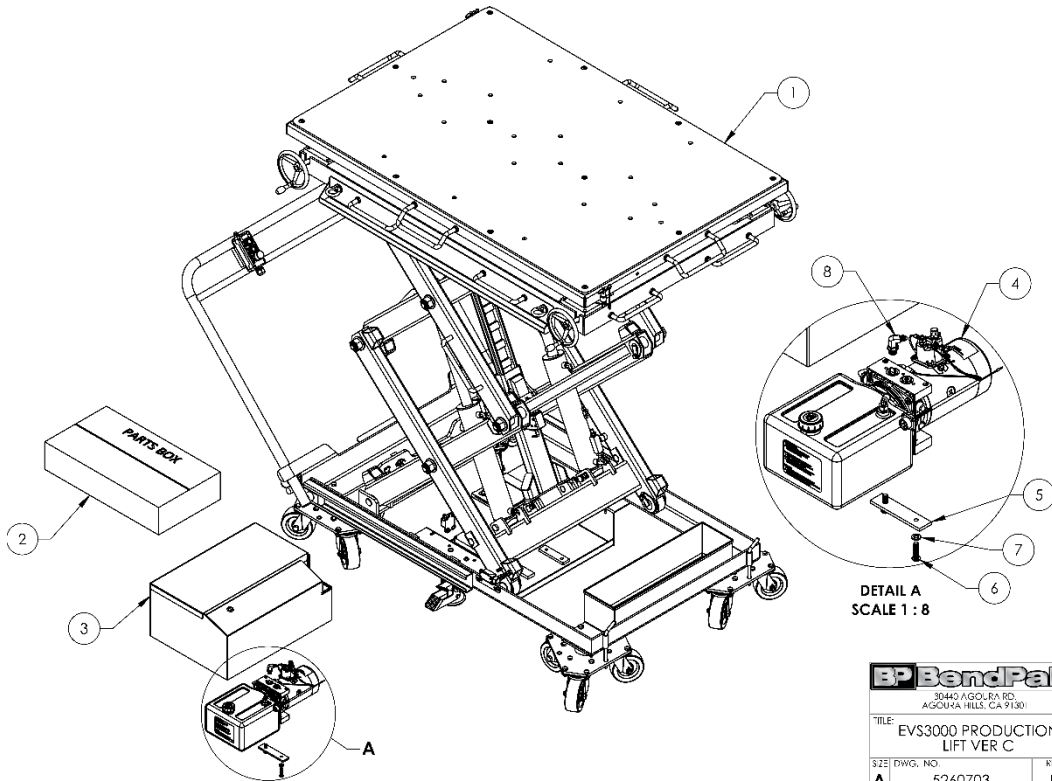

BP BendPak
30440 AGOURA RD.
AGOURA HILLS, CA 91301

TITLE: EVS3000 PRODUCTION LIFT VER C

SIZE DWG. NO. REV
A 5260703 E

SCALE: 1:16 SHEET 2 OF 4

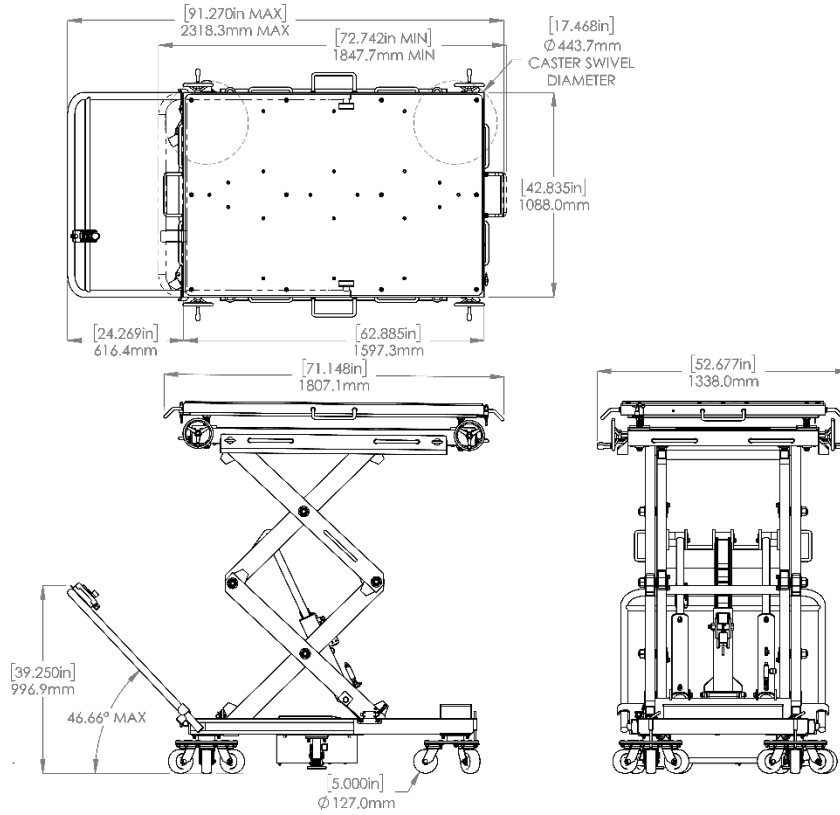

BP BendPak		
30440 AGOURA RD. AGOURA HILLS, CA 91301		
TITLE: EVS3000 PRODUCTION LIFT VER C		
SZL	DWG. NO.	REV
A	5260703	E
SCALE: 1:22		SHEET 3 OF 4

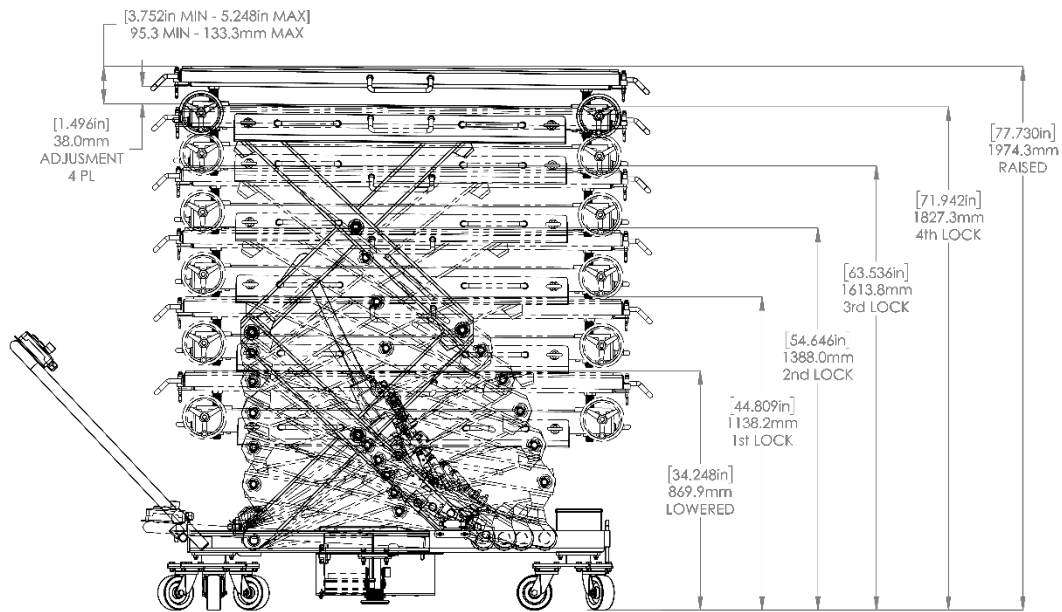

BP BendPak		
30440 AGOURA RD. AGOURA HILLS, CA 91301		
TITLE: EVS3000 PRODUCTION LIFT VER C		
SZL	DWG. NO.	REV
A	5260703	E
SCALE: 1:15		SHEET 4 OF 4

1. SAFETY LOCKS POSITIONS: 4
2. ALL DIMENSIONS SHOWN WITH JACKS AT MAXIMUM ADJUSTMENT

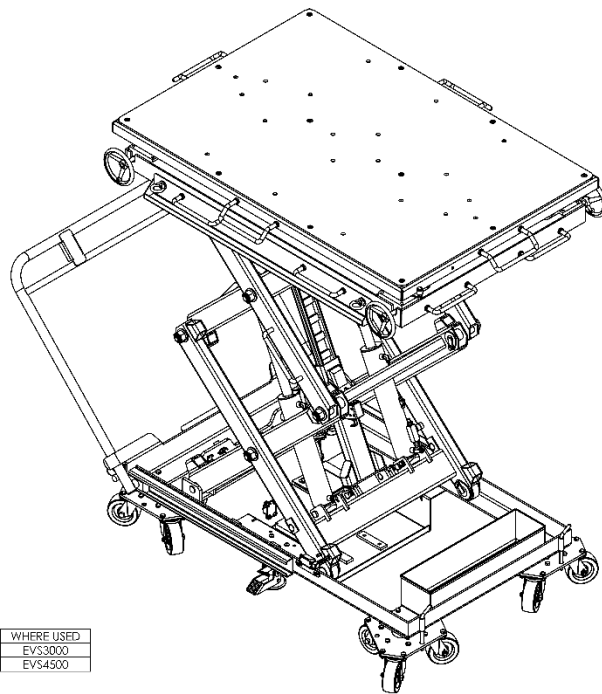

WHERE USED
EV33000
EV4500

- NOTE: UNLESS OTHERWISE SPECIFIED**
1. REFER TO MODEL FOR ADDITIONAL INFORMATION
 2. SEE SHIPPING INSTRUCTIONS FOR FINAL PACKAGING
 3. ASSEMBLE ITEMS AS SHOWN

NEXT ASSEMBLY
5260703
5260706

ITEM NO	PART NUMBER	DESCRIPTION	QTY	REV
1	5216226	EVS BASE SCISSOR ASSEMBLY	1	D
2	5602012	EVS SCISSOR CLEVIS PIN WELDMENT, M10	2	A
3	5602013	EVS TOP CYLINDER CLEVIS PIN WELDMENT, M10	3	A
4	5216232	EVS3000/4500 DECK, TILT AND SLIP PLATE ASSEMBLY	1	D
5	5602054	CYLINDER ASSEMBLY Ø3.0 x 14.18	2	A
6	5530491	HHB M10 x 1.5 x 1.6 FT. CL 10.9	9	-
7	5550395	FTG TEE Ø4 COMP x Ø4 COMP x Ø4 COMP	1	-
8	5550083	FTG ELB Ø4 COMP x Ø4 NPT	2	-
9	5550222	FTG TEE Ø4 JIC x Ø4 NPT x Ø4 F NPT	1	-
10	5550147	FTG NPL Ø4 JIC x Ø4 NPT	1	-
11	5570285	HYDRAULIC HOSE ASSEMBLY Ø6.35 x 750mm DB	1	B
12	5570266	HYDRAULIC HOSE ASSEMBLY Ø6.4 x 580mm SB	1	A
13	5570795	1/4" POLY-FLO TUBING	1230mm	-
14	5216229	EVS SAFETY ASSEMBLY	1	A
15	5602015	EVS SAFETY CLEVIS PIN WELDMENT, M10	2	A
16	5550212	FTG NPL Ø6 NPT x Ø4 NPT	1	-
17	5590115	FLOW CONTROL VALVE, 3/8 NPT 5000psi	1	-
18	5550100	FTG NPL Ø4 JIC x Ø6 NPT	1	-
19	5746719	EVS LOWER CYLINDER PIN	2	A
20	5737415	EVS LOWER CYLINDER PIN PLATE, M10	2	A
21	5216228	EVS STEERING HANDLE ASSEMBLY	1	A
22	5575075	EVS TRIPLE SWIVEL CASTER	4	-
23	5530106	HHB M10 x 1.5 x 35 FT. CL 10.9	16	-
24	5545200	WASHER M10 x Ø18 SL CL 10.9	33	-
25	5535013	NUT M10 x 1.5 NL CL 10.9	24	-
26	5505085	BENT PIN, Ø12 x 150mm	2	A
27	5580038	FLOOR LOCK, 7.75in	2	-
28	5737414	EVS FLOOR LOCK PLATE SPACER	2	A
29	5530489	BHSS M10 x 1.5 x 45 FT. CL 10.9	8	-
30	5216230	EVS ELECTRONICS ASSEMBLY	1	B

DESIGNER	NAME	DATE	
CHECKED	REV	00/08/2023	
APPROVED	BY		700-80 ACCOIRA RD. ACCOIRA HILLS, CA 91701
IF BOLD ANGLE INDICATION			I.I.L.: EVS3000/4500 SUPERSTRUCTURE
			SCL DWG. NO. A 5245287
SCALE: 1:16			REV E
SHEET 1 OF 2			

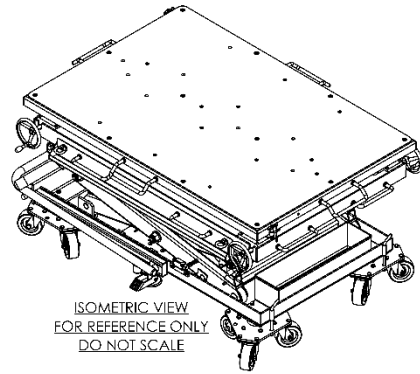
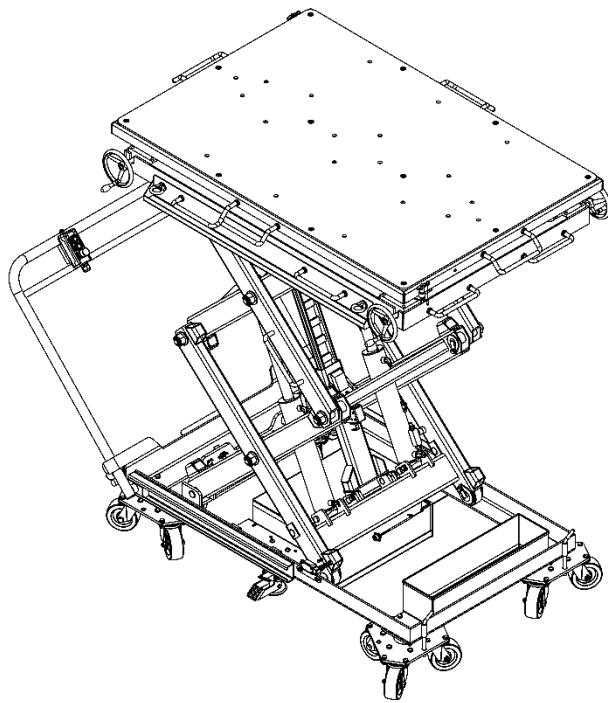

ISOMETRIC VIEW
FOR REFERENCE ONLY
DO NOT SCALE

ITEM NO	PART NUMBER	DESCRIPTION	QTY	REV
1	5245287	EVS3000/4500 SUPERSTRUCTURE	1	E
2	5250389	EVS PARTS BOX	1	A
3	5210386	EVS ELECTRONICS COVER ASSEMBLY	1	E
4	5585954	EVS POWER UNIT, 12V, DC; 2000 PSI PRV	1	-
5	5715046	POWER UNIT VIBRATION DAMPENER 132mm x 32mm	1	A
6	5530488	BHSS 3/8-16" x 1 3/8" FT, GR 8	2	-
7	5545130	WASHER 3/8" SL, GR 8	2	-
8	5550103	FTG ELB -04 JIC -06 ORB	1	-

DO NOT SCALE DRAWING

DRAWN: KC DATE: 08/28/2023

CHECKED:

THIRD ANGLE PROJECTION

SMILEY FACE

PROPRIETARY AND CONFIDENTIAL
THIS DOCUMENT IS UNCLASSIFIED
DATE 08/28/2023 BY 60322 UCBAW/STP/STP
EXEMPT FROM GDS AUTOMATIC DOWNGRADING
EXEMPT FROM GDS AUTOMATIC DOWNGRADING
DATE 08/28/2023

BP BendPak
30446 AGOURA RD.
AGOURA HILLS, CA 91301

TITLE: EVS4500 PRODUCTION LIFT VER C

SIZE: DWG. NO. 5260706

REV: E

SCALE: 1:16

SHEET 1 OF 4

NOTE: UNLESS OTHERWISE SPECIFIED...
 1. REFER TO MODEL FOR ADDITIONAL INFORMATION
 2. SEE COLORS & GRAPHICS FOR LABEL PLACEMENT
 3. ASSEMBLE ITEMS AS SHOWN
 4. SEE SHIPPING INSTRUCTIONS FOR FINAL PACKAGING

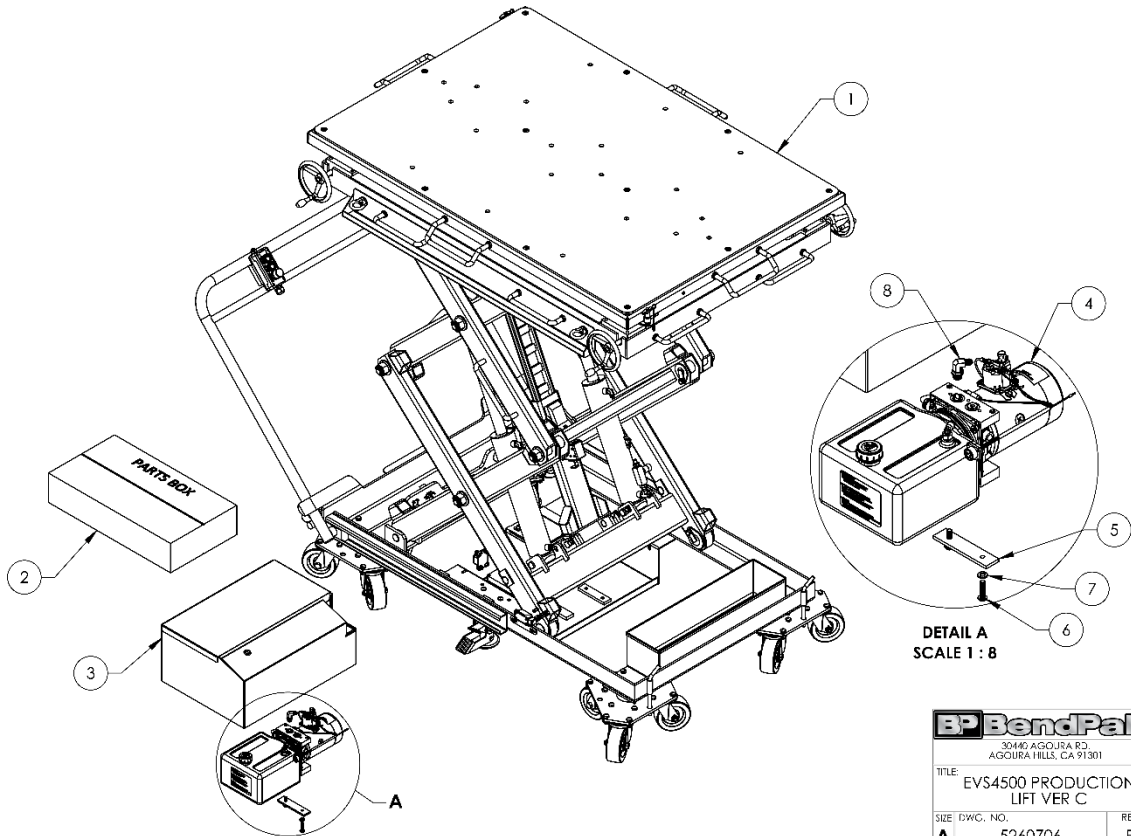

BP BendPak
30446 AGOURA RD.
AGOURA HILLS, CA 91301

TITLE: EVS4500 PRODUCTION LIFT VER C

SIZE: DWG. NO. 5260706

REV: E

SCALE: 1:16

SHEET 2 OF 4

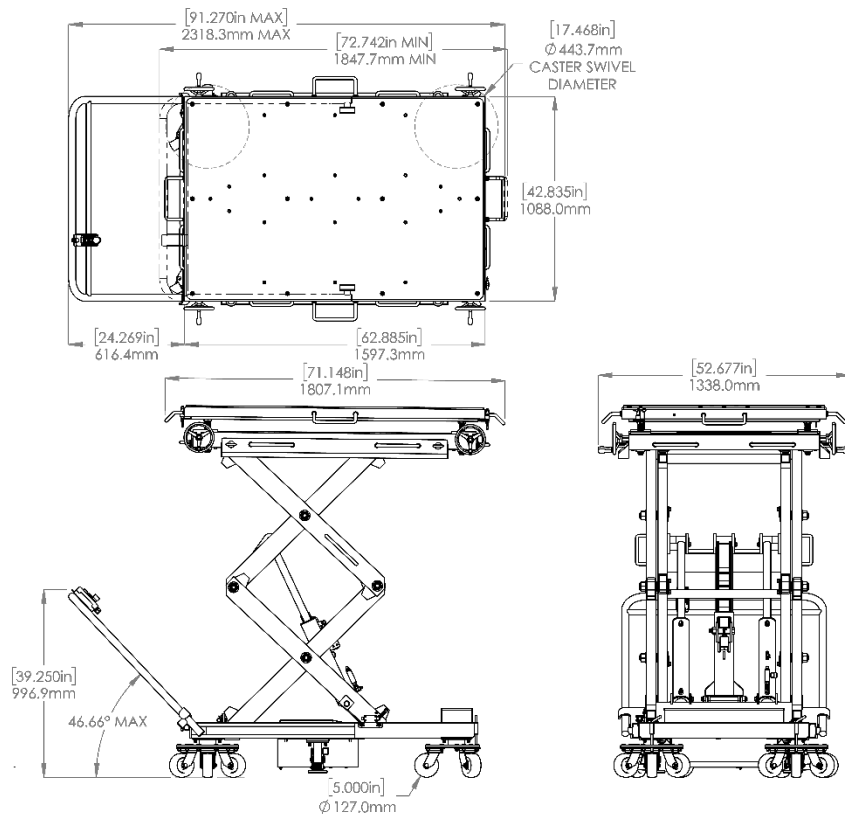

BP BendPak	
30440 AGOURA RD. AGOURA HILLS, CA 91301	
TITLE: EVS4500 PRODUCTION LIFT VER C	
SZL DWG. NO.	REV
A 5260706	E
SCALE: 1:22	
SHEET 3 OF 4	

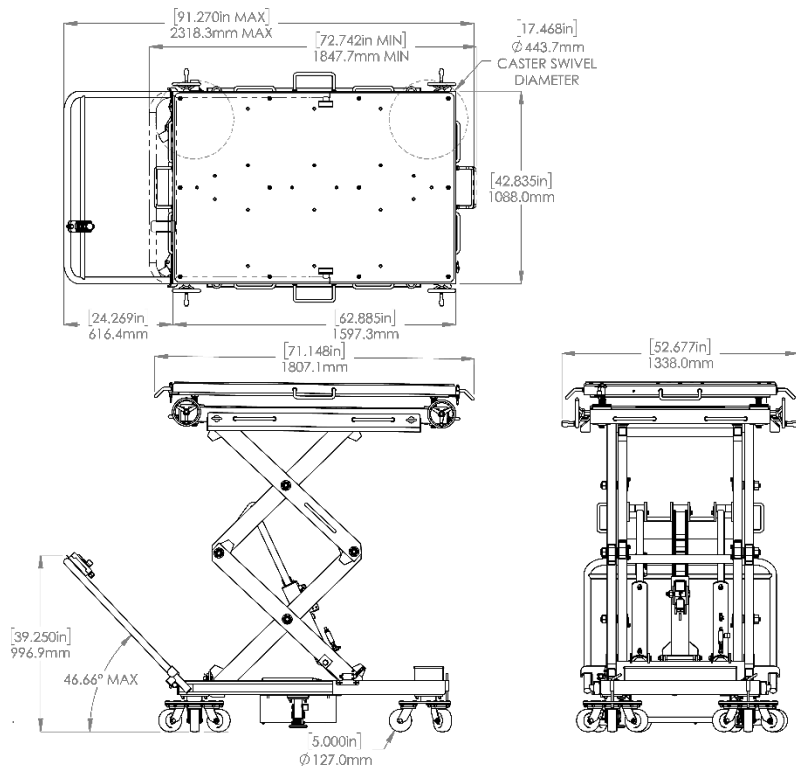

BP BendPak	
30440 AGOURA RD. AGOURA HILLS, CA 91301	
TITLE: EVS4500 PRODUCTION LIFT VER C	
SZL DWG. NO.	REV
A 5260706	E
SCALE: 1:22	
SHEET 3 OF 4	

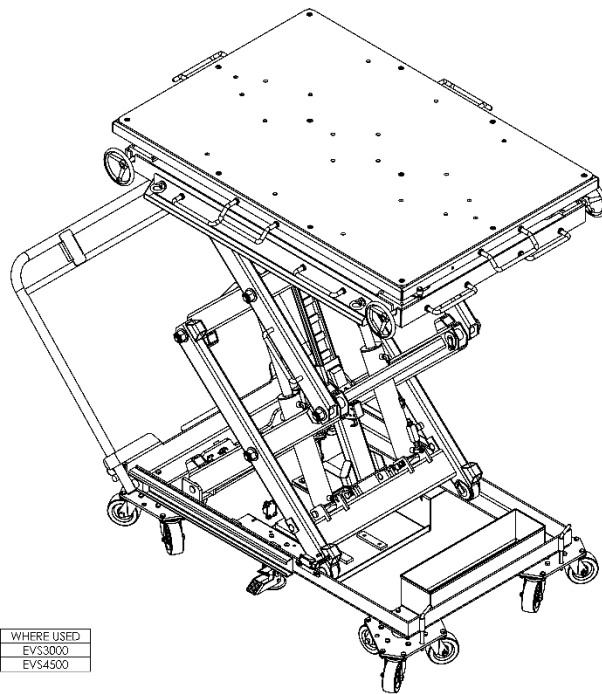

WHERE USED
EV33000
EV34500

- NOTE: UNLESS OTHERWISE SPECIFIED**
1. REFER TO MODEL FOR ADDITIONAL INFORMATION
 2. SEE SHIPPING INSTRUCTIONS FOR FINAL PACKAGING
 3. ASSEMBLE ITEMS AS SHOWN

ITEM NO	PART NUMBER	DESCRIPTION	QTY	REV
1	5216226	EVS BASE SCISSOR ASSEMBLY	1	D
2	5602012	EVS SCISSOR CLEVIS PIN WELDMENT, M10	2	A
3	5602013	EVS TOP CYLINDER CLEVIS PIN WELDMENT, M10	3	A
4	5216232	EVS3000/4500 DECK, TILT AND SLIP PLATE ASSEMBLY	1	D
5	5602054	CYLINDER ASSEMBLY Ø3.0 x 14.18	2	A
6	5530491	HHB M10 x 1.5 x 1.6 FT. CL 10.9	9	-
7	5550395	FTG TEE Ø4 COMP x Ø4 COMP x Ø4 COMP	1	-
8	5550083	FTG ELB Ø4 COMP x Ø4 NPT	2	-
9	5550222	FTG TEE Ø4 JIC x Ø4 NPT x Ø4 F NPT	1	-
10	5550147	FTG NPL Ø4 JIC x Ø4 NPT	1	-
11	5570285	HYDRAULIC HOSE ASSEMBLY Ø6.35 x 750mm DB	1	B
12	5570264	HYDRAULIC HOSE ASSEMBLY Ø6.4 x 580mm SB	1	A
13	5570795	1/4" POLY-FLO TUBING	1230mm	-
14	5216229	EVS SAFETY ASSEMBLY	1	A
15	5602015	EVS SAFETY CLEVIS PIN WELDMENT, M10	2	A
16	5550212	FTG NPL Ø6 NPT x Ø4 NPT	1	-
17	5590115	FLOW CONTROL VALVE, 3/8 NPT 5000psi	1	-
18	5550100	FTG NPL Ø4 JIC x Ø6 NPT	1	-
19	5746719	EVS LOWER CYLINDER PIN	2	A
20	5737415	EVS LOWER CYLINDER PIN PLATE, M10	2	A
21	5216228	EVS STEERING HANDLE ASSEMBLY	1	A
22	5575075	EVS TRIPLE SWIVEL CASTER	4	-
23	5530106	HHB M10 x 1.5 x 35 FT. CL 10.9	16	-
24	5545200	WASHER M10 x Ø18 SL CL 10.9	33	-
25	5535013	NUT M10 x 1.5 NL CL 10.9	24	-
26	5550085	BENT PIN Ø12 x 150mm	2	A
27	5580038	FLOOR LOCK, 7.75in	2	-
28	5737414	EVS FLOOR LOCK PLATE SPACER	2	A
29	5530489	BHSS M10 x 1.5 x 45 FT. CL 10.9	8	-
30	5216230	EVS ELECTRONICS ASSEMBLY	1	B

DESIGNER: NAME DATE
 CHECKED: NAME DATE
 TITLE: EVS3000/4500 SUPERSTRUCTURE
 SCL DWG NO: 5245287
 REV: E
 SCALE: 1:16 SHEET 1 OF 2

PROFESSIONAL AND CONFIDENTIAL
 ALL RIGHTS RESERVED © BENDPAK INC. 2019
 30445 ASCOURA RD. AGOURA HILLS, CA 91301
 TEL: 909.251.1111 FAX: 909.251.1112
 WWW.BENDPAK.COM

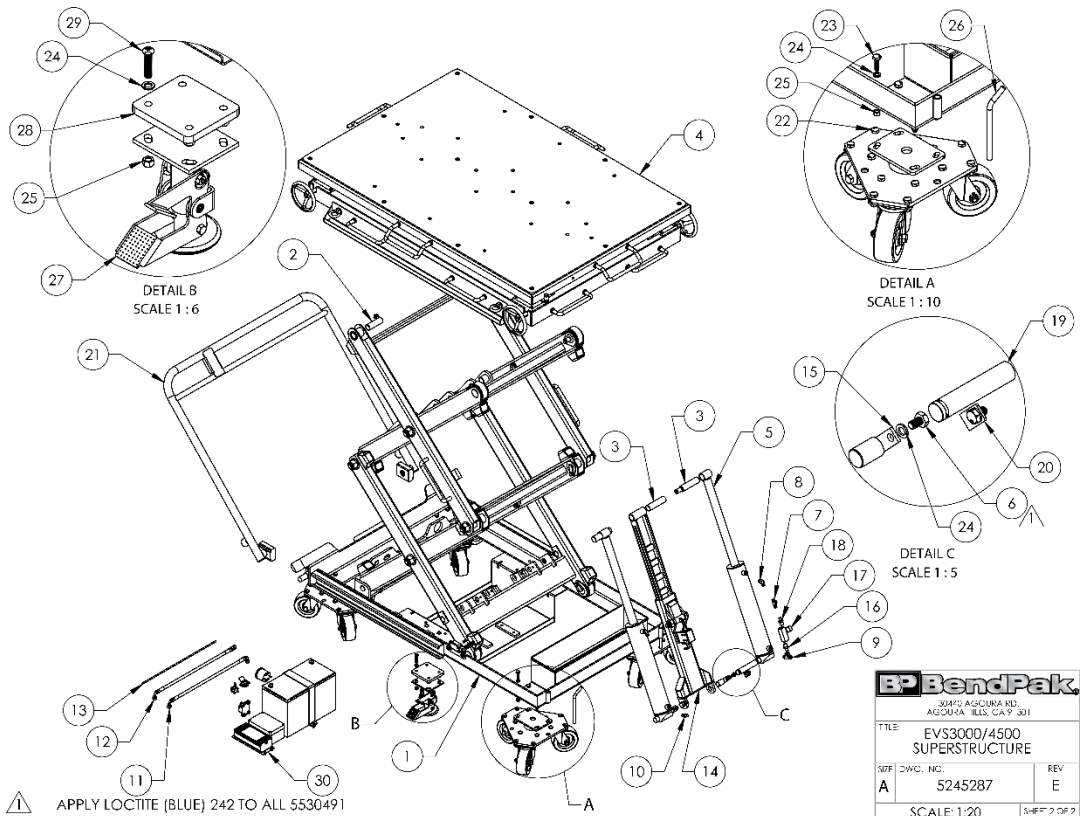

BP BendPak
 30445 ASCOURA RD.
 AGOURA HILLS, CA 91301

TITLE: EVS3000/4500 SUPERSTRUCTURE
 SCL DWG NO: 5245287
 REV: E
 SCALE: 1:20 SHEET 2 OF 2

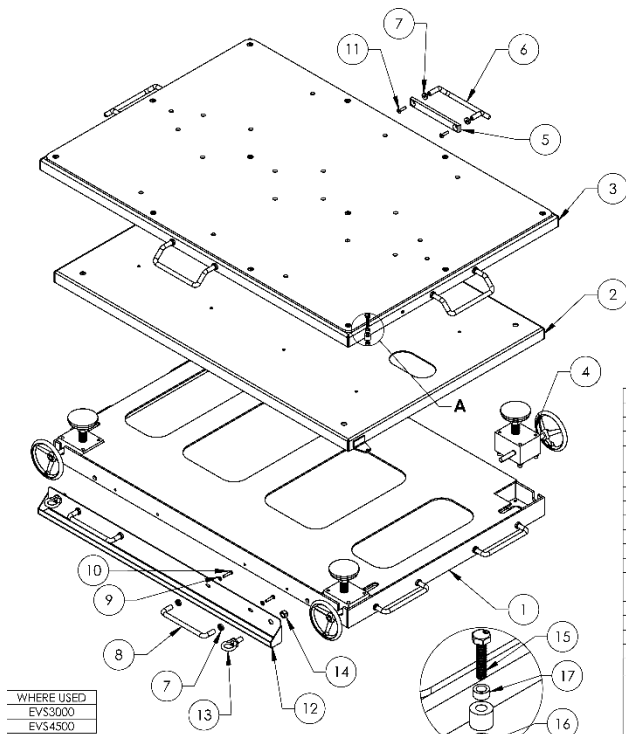

WHERE USED
EVS3000
EVS4500

- NOTE: UNLESS OTHERWISE SPECIFIED**
 1. REFER TO MODEL FOR ADDITIONAL INFORMATION
 2. ASSEMBLE ITEMS AS SHOWN

DETAIL A
 SCALE 1:4
 NEXT ASSEMBLY
 5245287

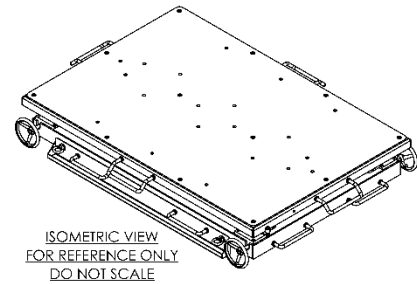

ISOMETRIC VIEW
 FOR REFERENCE ONLY
 DO NOT SCALE

ITEM NO	PART NUMBER	DESCRIPTION	QTY	REV
1	5601958	EVS TOP DECK WELDMENT	1	B
2	5602010	EVS TILT DECK WELDMENT	1	A
3	5216227	EVS3000/4500 SLIP PLATE ASSEMBLY	1	C
4	5216231	EVS SCREW JACK LEVELLING HANDLE ASSEMBLY	4	B
5	5716084	EVS SLIP PLATE SPACER	4	A
6	5701869	EVS DECK HANDLE	4	A
7	5335760	SPRAY WASHER/EVS HANDLE CUP	24	A
8	5335420	SPRAY WASHER/EVS HANDLE	8	A
9	5545012	WASHER M8 x Ø16 FLAT, CL10.9	16	-
10	5530011	HHB M8 x 1.25 x 35	16	-
11	5530459	FHSS M8 x 1.25 x 35 FT, CL10.9	8	-
12	5601970	EVS TOOL TRAY WELDMENT	2	A
13	5530082	EYE M16 x 2.0 x 95, 35 ID	4	-
14	5530008	NUT M16 x 2.0 NL, CL10.9	4	-
15	5530167	HHB M10 x 1.5 x 45 FT, CL10.9	2	-
16	5530013	NUT M10 x 1.5 NL, CL10.9	2	-
17	5716108	EVS SLIP PLATE/TILT DECK SPACER, M10	2	A

DO NOT SCALE DRAWING

DRAWN	TM	DATE	08/22/2023
CHECKED			

THIRD ANGLE PROJECTION

BP BendPak
 3040 AGOURA RD.
 AGOURA HILLS, CA 91301

TITLE: EVS3000/4500 DECK, TILT AND SLIP PLATE ASSEMBLY

SIZE DWG. NO. A 5216232 REV. D

SCALE: 1:15 SHEET 1 OF 1

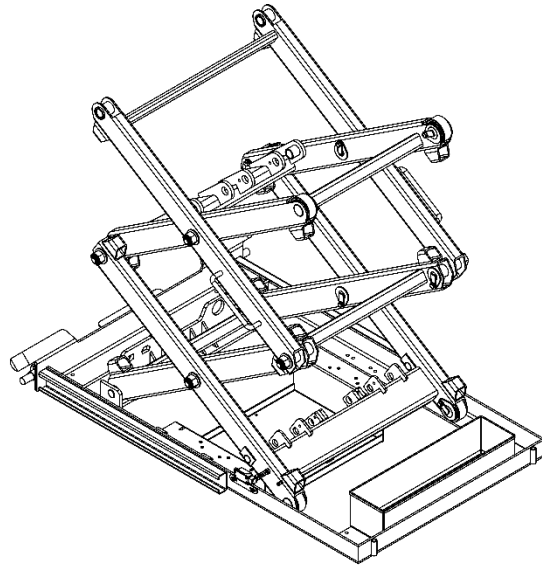

WHERE USED
EVS3000
EVS4500
EVS4500T

- NOTE: UNLESS OTHERWISE SPECIFIED**
 1. REFER TO MODEL FOR ADDITIONAL INFORMATION
 2. ASSEMBLE ITEMS AS SHOWN

NEXT ASSEMBLY
 5245287
 5245292

ITEM NO	PART NUMBER	DESCRIPTION	QTY	REV
1	5601959	EVS BASE WELDMENT	1	C
2	5601960	EVS BOTTOM INNER SCISSOR ARM WELDMENT	1	B
3	5601961	EVS TOP INNER SCISSOR ARM WELDMENT	1	B
4	5601962	EVS TOP OUTER SCISSOR ARM WELDMENT	1	A
5	5601963	EVS BOTTOM OUTER SCISSOR ARM WELDMENT	1	B
6	5602014	EVS ROLLER PIN WELDMENT, M10	4	A
7	5216053	EVS ROLLER ASSEMBLY	4	A
8	5737248	EVS ROLLER SPACER	8	A
9	5565349	BUSHING 36 x 30 x 62 BR OI	4	-
10	5565366	BUSHING 36 x 30 x 56 BR OI	16	-
11	5602016	EVS SCISSOR ARM PIN WELDMENT, M10	8	A
12	5545415	WASHER M30 x 56 FLAT	8	-
13	5535211	NUT M27 x 3.0 NL	8	-
14	5540004	C RING Ø19mm OD DIN M1800 0190	8	-
15	5530281	HHB M10 x 1.5 x 10 FT, CL 10.9	12	-
16	5520076	ROCKER LIMIT SWITCH YBLX-ME/B108	1	-
17	5701817	EVS LIMIT SWITCH BRACKET	1	B
18	5530756	HHB M6 x 1.0 x 25 FT, CL 10.9	1	-
19	5535112	NUT M6 x 1.0	1	-
20	5545026	WASHER M6 x Ø12 SL	2	-
21	5530023	BHPS M6 x 1 x 12	2	-
22	5602012	EVS SCISSOR CLEVIS PIN WELDMENT, M10	2	A
23	5530491	HHB M10 x 1.5 x 16 FT, CL 10.9	2	-
24	5746726	EVS STEERING HANDLE BASE SIOP SLIDE	2	A
25	5580032	T HANDLE M8 x 1.25 x 30 FT	2	-
26	5545200	WASHER M10 x Ø18 SL, CL10.9	14	-

DO NOT SCALE DRAWING

DRAWN	RK	DATE	08/08/2023
CHECKED			

THIRD ANGLE PROJECTION

BP BendPak
 3040 AGOURA RD.
 AGOURA HILLS, CA 91301

TITLE: EVS BASE SCISSOR ASSEMBLY

SIZE DWG. NO. A 5216226 REV. D

SCALE: 1:14 SHEET 1 OF 2

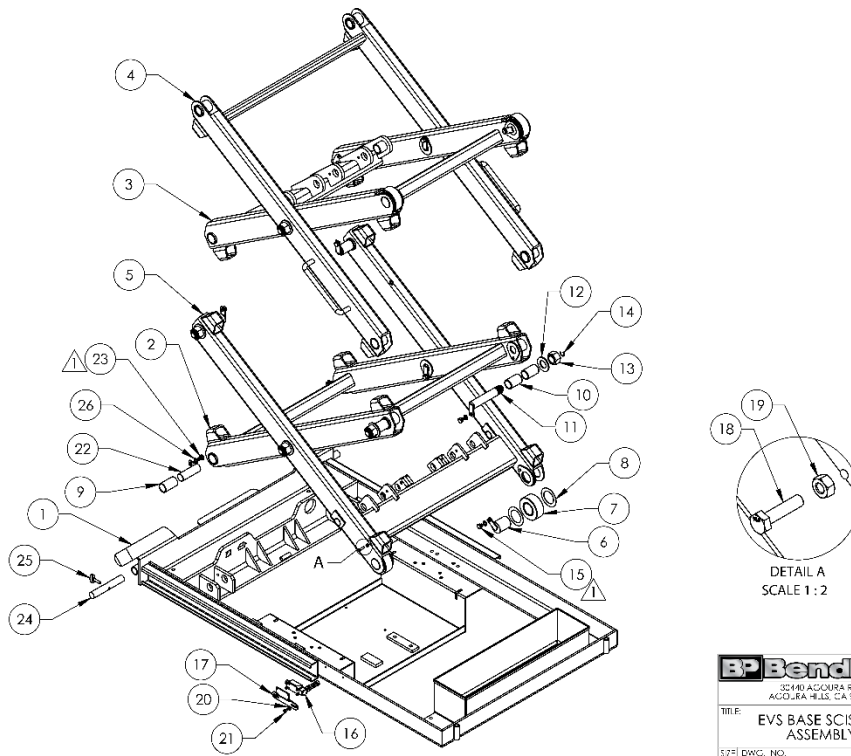

1 APPLY LOCTITE (BLUE) 242 TO ALL 5530281 AND 5530491

BP BendPak
 32415 AGOONRA RD.
 AGOONRA HILLS, CA 91301

TITLE: EVS BASE SCISSOR ASSEMBLY

57 DWG. NO. 5216226 REV D

SCALE: 1:15 SHEET 2 OF 2

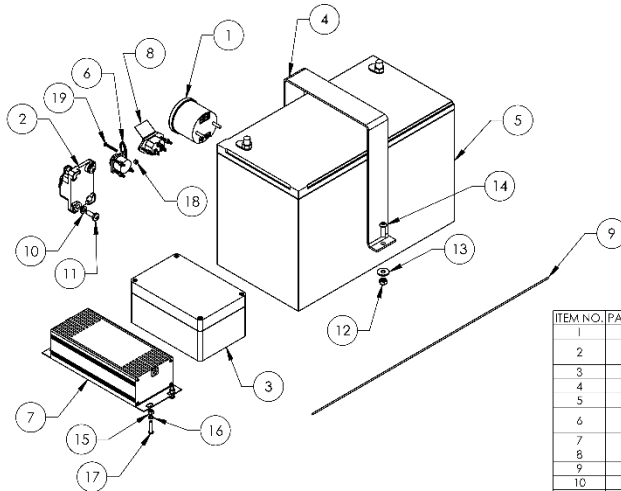

WHERE USED
EVS3000
EVS4500
EVS4500T

- NOTE: UNLESS OTHERWISE SPECIFIED**
1. REFER TO MODEL FOR ADDITIONAL INFORMATION
 2. SEE SHIPPING INSTRUCTIONS FOR FINAL PACKAGING
 3. ASSEMBLE ITEMS AS SHOWN
 4. (*)LENGTH FOR REFERENCE ONLY

ITEM NO.	PART NUMBER	DESCRIPTION	QTY.	REV
1	5520075	BATTERY LIFE INDICATOR, 12V DC, Ø56mm	1	-
2	5520160	72VDC, 250A BREAKER, SURFACE MOUNT, MANUAL RESET	1	-
3	5601948	EVS JUNCTION BOX ASSEMBLY	1	A
4	5580022	EVS BATTERY TIE DOWN BRACKET	1	A
5	5520080	BATTERY, 12V	1	-
6	5520078	4 PIN PANEL SOCKET CONNECTOR, 500V 20A	1	-
7	5520077	BATTERY CHARGER 12V 15A	1	-
8	5520079	CHARGER POWER INLET, 250V, 15A	1	-
9	5520038	WIRE, AWG 16-2, SJ00W	2100mm	-
10	5545026	WASHER M6 x Ø12 SL	2	-
11	5530791	PHPS M6 x 1.0 x 18mm	2	-
12	5535357	NUT M6 x 1.0 NL CL10.9	2	-
13	5545339	WASHER, M6 x 18mm FLAT	2	-
14	5530665	BHSK M6 x 1.0 x 20 FT. CL 10.9	2	-
15	5535010	NUT M4 x 0.7, NL CL8	4	-
16	5545043	WASHER M4 x Ø7.6 SL	4	-
17	5530362	BHSK M4 x 0.7 x 20 CL 10.9	4	-
18	5535020	NUT M3 x 0.5, NL CL8	6	-
19	5530425	PHPS M3 x 0.5 x 25	6	-

BP BendPak
 32415 AGOONRA RD.
 AGOONRA HILLS, CA 91301

DATE: 08/25/2023

CHANGED BY: [Signature]

UNIFORM: 1/16" = 3mm

THIRD ANGLE PROJECTION

TITLE: EVS ELECTRONICS ASSEMBLY

SIZE: A DWG. NO.: 5216230 REV B

SCALE: 1:6 SHEET 1 OF 2

NEXT ASSEMBLY
5245287
5245292

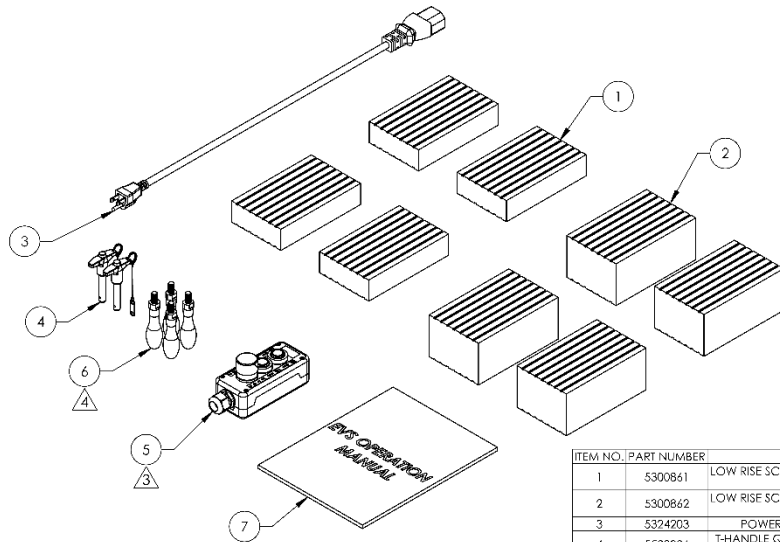

WHERE USED
EVS3000
EVS4500
EVS4500T

- NOTE: UNLESS OTHERWISE SPECIFIED**
1. REFER TO MODEL FOR ADDITIONAL INFORMATION
 2. REFER TO MODEL FOR ADDITIONAL INFORMATION
 3. SEE 5585924 OR 5585954 FOR MORE INFORMATION
 4. SEE 5580034 MORE INFORMATION

ITEM NO.	PART NUMBER	DESCRIPTION	QTY.	REV
1	5300861	LOW RISE SCISSOR LIFT 38mm RUBBER PAD KIT, SET OF 4	1	A
2	5300862	LOW RISE SCISSOR LIFT 75mm RUBBER PAD KIT, SET OF 4	1	A
3	5324203	POWER CORD, 125V 10A, 3 PIN, 6ft	1	-
4	5580036	T-HANDLE QUICK RELEASE PIN, Ø10 x 40mm, M6 LANYARD	2	A
5		PENDANT CONTROL EVS PENDANT CONTROL	1	-
6	5580034-2	ROUND HAND WHEEL HANDLE EVS OPERATION MANUAL	4	-
7	5900376		1	-

DESIGNED BY	NAME	DATE	BP BendPak 30440 AGOURA RD. AGOURA HILLS, CA 91301
DRAWN	CA	01/22/2024	
CHECKED	OR	01/16/2024	
THIRD ANGLE PROJECTION	TITLE		
	EVS PARTS BOX		
SIZ.	DWG. NO.	REV	
A	5250389	A	
SCALE: 1:6			SHEET 1 OF 1

NEXT ASSEMBLY
5260703
5260706
5260715

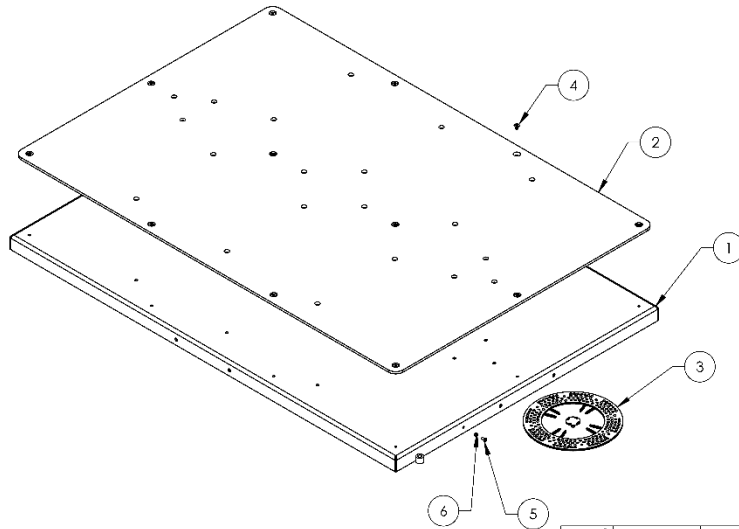

WHERE USED
EVS3000
EVS4500

- NOTE: UNLESS OTHERWISE SPECIFIED**
1. REFER TO MODEL FOR ADDITIONAL INFORMATION
 2. SEE SHIPPING INSTRUCTIONS FOR FINAL PACKAGING
 3. ASSEMBLE ITEMS AS SHOWN

ITEM NO.	PART NUMBER	DESCRIPTION	QTY.	REV
1	5601949	EVS3000/4500 SLIP PLATE WELDMENT	1	C
2	5716099	EVS3000/4500 SLIP DECK PLASTIC COVER	1	B
3	5700446	SLIP PLATE BALL RING ASSEMBLY	8	-
4	5530382	FHSS M8 x 1.25 x 12 CL10.9	12	-
5	5530472	BHSS M8 x 1.00 x 12 FT. CL 10.9	2	-
6	5535357	NUT M6 x 1.0 NL CL10.9	2	-

DESIGNED BY	NAME	DATE	BP BendPak 30440 AGOURA RD. AGOURA HILLS, CA 91301
DRAWN	RC	09/08/2023	
CHECKED	OR	02/27/2022	
THIRD ANGLE PROJECTION	TITLE		
	EVS3000/4500 SLIP PLATE ASSEMBLY		
SIZ.	DWG. NO.	REV	
A	5216227	C	
SCALE: 1:12			SHEET 1 OF 1

NEXT ASSEMBLY
5216232

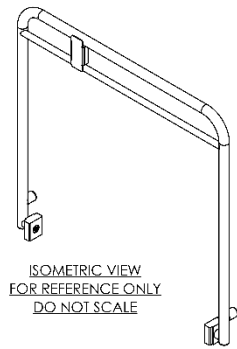
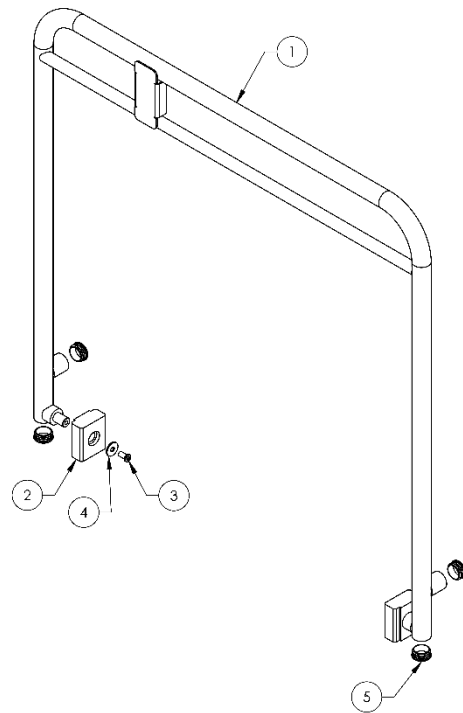

ISOMETRIC VIEW
FOR REFERENCE ONLY
DO NOT SCALE

WHERE USED
EV33000
EV34500
EV34500T

- NOTE: UNLESS OTHERWISE SPECIFIED**
1. REFER TO MODEL FOR ADDITIONAL INFORMATION
 2. ASSEMBLE ITEMS AS SHOWN
 3. SEE SHIPPING INSTRUCTIONS FOR FINAL PACKAGING

NEXT ASSEMBLY
5245287
5245292

ITEM NO	PART NUMBER	DESCRIPTION	QTY	REV
1	5601944	EVS STEERING HANDLE WELDMENT	1	A
2	5716097	EVS STEERING HANDLE SLIDE BLOCK	2	A
3	5530483	SHCS ULP M10 x 1.5 x 20 FT. CL 8.8	2	A
4	5545048	WASHER M10 x Ø30 FLAT	2	A
5	5716098	PLASTIC TUBE COVER Ø36mm	4	A

DO NOT SCALE DRAWING	NAME	DATE	
DRAWN	REK	08/17/2021	
CHECKED	OK	10/12/2023	3040 AGOURA RD. AGOURA HILL, CA 91301
DIMENSIONS ARE IN MM	THERD ANGLE PROJECTION		TITLE: EVS STEERING HANDLE ASSEMBLY SIZE: DWG. NO.: 5216228 REV: A
PROPERLY AND COMPLETELY THE SOLE PROPERTY OF BENDPAK INC. ALL RIGHTS RESERVED. NO PARTS MAY BE REPRODUCED OR TRANSMITTED IN ANY FORM OR BY ANY MEANS, ELECTRONIC OR MECHANICAL, WITHOUT THE WRITTEN PERMISSION OF BENDPAK INC.			SCALE: 1:8 SHEET 1 OF 1

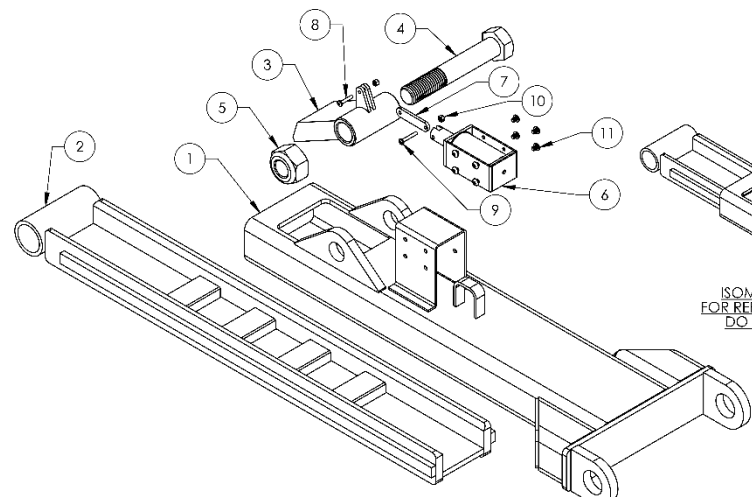

ISOMETRIC VIEW
FOR REFERENCE ONLY
DO NOT SCALE

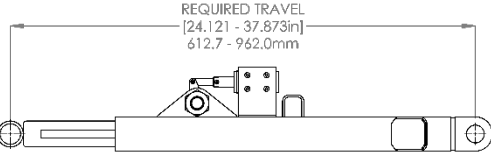

WHERE USED
EV33000
EV34500
EV34500T

- NOTE: UNLESS OTHERWISE SPECIFIED**
1. REFER TO MODEL FOR ADDITIONAL INFORMATION
 2. SEE SHIPPING INSTRUCTIONS FOR FINAL PACKAGING
 3. ASSEMBLE ITEMS AS SHOWN

NEXT ASSEMBLY
5245287
5245292

ITEM NO	PART NUMBER	DESCRIPTION	QTY	REV
1	5601965	EVS SAFETY TUBE WELDMENT	1	A
2	5601966	EVS SAFETY STOP WELDMENT	1	A
3	5601967	EVS SAFETY CATCH WELDMENT	1	A
4	5530349	HHB M20 x 2.5 x 120 PT. CL 10.9	1	B
5	5535017	NUT M20 x 2.5 NL CL 10.9	1	-
6	5520087	SOLENOID 24VDC FULL 1.00 STROKE	1	-
7	5737341	EVS SAFETY SOLENOID LINKAGE	1	A
8	5530470	PHPS M3 x 0.5 x 16mm FT. CL 4.8	1	-
9	5530471	PHPS M3 x 0.5 x 20mm FT. CL 4.8	1	-
10	5535020	NUT M3 x 0.5 NL CL 8	2	-
11	5530482	BHSS M4 x 0.7 x 5mm FT. CL 10.9	8	-

DO NOT SCALE DRAWING	NAME	DATE	
DRAWN	REK	08/09/2021	
CHECKED	OK	07/12/2023	3040 AGOURA RD. AGOURA HILL, CA 91301
DIMENSIONS ARE IN MM	THERD ANGLE PROJECTION		TITLE: EVS SAFETY ASSEMBLY SIZE: DWG. NO.: 5216229 REV: A
PROPERLY AND COMPLETELY THE SOLE PROPERTY OF BENDPAK INC. ALL RIGHTS RESERVED. NO PARTS MAY BE REPRODUCED OR TRANSMITTED IN ANY FORM OR BY ANY MEANS, ELECTRONIC OR MECHANICAL, WITHOUT THE WRITTEN PERMISSION OF BENDPAK INC.			SCALE: 1:4 SHEET 1 OF 1

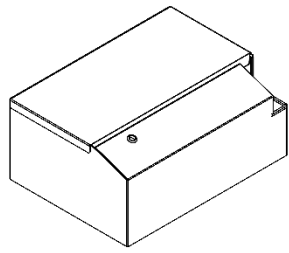

ISOMETRIC VIEW
FOR REFERENCE ONLY
DO NOT SCALE

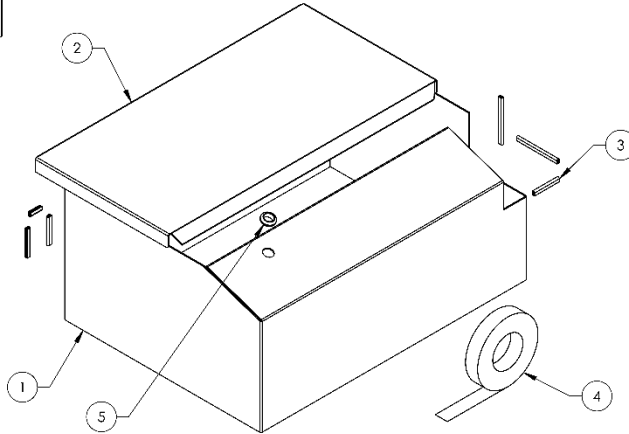

WHERE USED
EVS3000
EVS4500
EVS4500T

NOTE: UNLESS OTHERWISE SPECIFIED
1. REFER TO MODEL FOR ADDITIONAL INFORMATION

NEXT ASSEMBLY
5260703
5260706
5260715

ITEM NO	PART NUMBER	DESCRIPTION	QTY	REV
1	5601971	EVS ELECTRONICS COVER WELDMENT	1	B
2	5701867	EVS COVER, TOP	1	B
3	5718047	NEOPRENE EDGE TRIM, 3mm	*375mm	-
4	5520315	ELECTRICAL TAPE 3/4" x 60ft	1	-
5	5520093	PUSH-IN RUBBER GROMMET, 18mm x 2mm	1	A

NO. OF SHEETS	NO. OF SHEETS DRAWN	NAME	DATE	COMPANY
1	1	DR	06/17/2024	BP BendPak
1	1	CHK	01/19/2024	1445 JEMANWOOD DR SAN JUAN CA, 95060

UNITS	PROJECTION	TITLE	SIZE	DWG. NO.	REV
MM	1ST ANGLE	EVS ELECTRONICS COVER ASSEMBLY	A	5210386	E

SCALE: 1:6 SHEET 1 OF 1

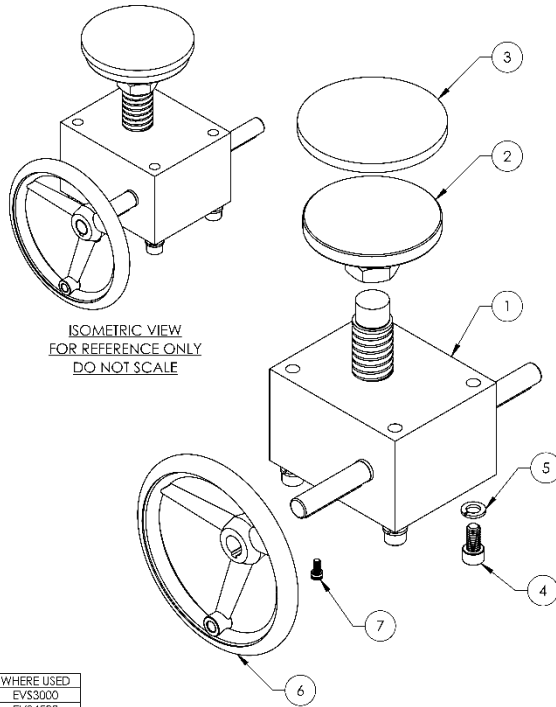

ISOMETRIC VIEW
FOR REFERENCE ONLY
DO NOT SCALE

WHERE USED
EVS3000
EVS4500

NOTE: UNLESS OTHERWISE SPECIFIED
1. REFER TO MODEL FOR ADDITIONAL INFORMATION
2. ASSEMBLE ITEMS AS SHOWN

NEXT ASSEMBLY
5216232

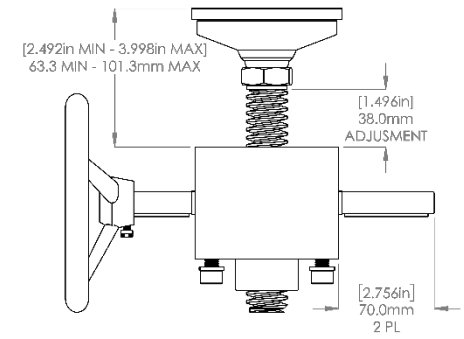

ITEM NO	PART NUMBER	DESCRIPTION	QTY	REV
1	5580023	MANUAL SCREW JACK, 38mm x 5000lb	1	-
2	5580033	SCREW JACK LEVELLING MOUNT	1	-
3	5715051	EVS LEVELLING PAD, TILT DECK	1	A
4	5400940	SHCS M10 x 1.5 x 20 FL, CL 12.9	4	A
5	5545200	WASHER M10 x Ø18 SL, CL 10.9	4	-
6	5580034	ROUND HAND WHEEL, Ø160mm	1	-
7	5590486	SHCS M5 x 0.8 x 10 FT, CL 10.9	1	-

NO. OF SHEETS	NO. OF SHEETS DRAWN	NAME	DATE	COMPANY
1	1	DR	08/22/2023	BP BendPak
1	1	CHK		3916 AGOURA RD AGOURA HILLS, CA 91301

UNITS	PROJECTION	TITLE	SIZE	DWG. NO.	REV
MM	1ST ANGLE	EVS SCREW JACK LEVELLING HANDLE ASSEMBLY	A	5216231	B

SCALE: 1:3 SHEET 1 OF 1

Automotive Lift Institute (ALI) Store

You probably checked the [ALI's Directory of Certified Lifts](http://www.autolift.org/ali-directory-of-certified-lifts/) before making your most recent Lift purchase, but did you know the [ALI Store](http://www.autolift.org/ali-store/) offers a wide variety of professional, easy-to-use, and reasonably priced training and safety materials that will make your garage a safer place to work? *The ALI Store is your trusted source for workplace safety!*



Lifting It Right Online Certificate Course. Make *sure* you and your people are lifting vehicles the right way.



ALI Lift Inspector Certification Program Registration. Become a ALI Certified Lift Inspector.

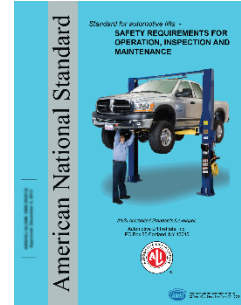

ANSI/ALI ALOIM Standard for Automotive Lifts. Safety Requirements for Operation, Inspection, and Maintenance.

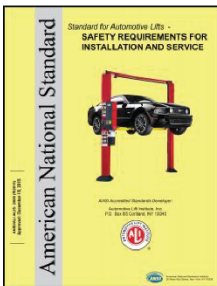

ANSI/ALI ALIS Standard. Safety Requirements for Installation and Service.

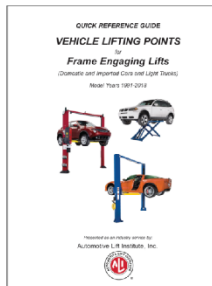

Guide to Identifying Vehicle Lifting Points for Frame-Engaging Lifts. Don't eyeball your lifting points, *know* where they are.



Lift Operator Safety Materials. Five safety documents in a single package.

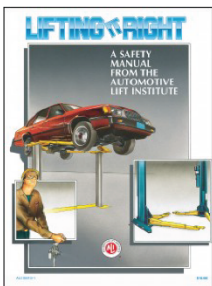

Lifting It Right. A hardcopy version of the *Lifting It Right* safety manual from the Automotive Lift Institute.

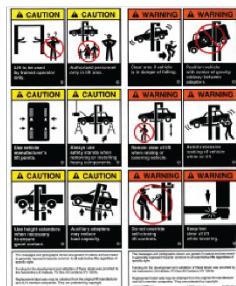

Uniform Warning Labels and Placards for 2-Posts. Labels in Mandarin, French Canadian, and Spanish are also available.



Safety Tips Card. Reminds your people of 13 key safety tips to follow daily.

Visit today and get the training and materials you need to work safely:
www.autolift.org/ali-store/

BendPak[®]

30440 Agoura Rd.
Agoura Hills, CA 91301 USA
[bendpak.com](https://www.bendpak.com)

© 2024 by BendPak Inc. All rights reserved.