

QUANTITIES ARE REPRESENTATIVE OF ENTIRE ASSEMBLY,
NOT JUST THE VIEW SHOWN.

DESCRIPTION	QTY	PART #
CENTER CONNECT TUBE	1	AT-PLUS-18
CONNECTING ARM	2	AT-PLUS-W07
STAND	2	AT-STD-W01
INNER PIVOT	2	AT-CLASSIC-W01
"W" ADJUSTMENT BRACKET	2	AT-PRO-W06
T-ARM	2	AT-PRO-W02
ATTACHMENT ARM	4	AT-PLUS-W06
ACME THREADED ROD	2	AT-PLUS-W08
ACME THREAD LOCK COLLAR	2	AT-PRO-14-W

PRODUCT IS SHIPPED WITH 1 BOX CONTAINING THE FOLLOWING HARDWARE FOR ASSEMBLY

DESCRIPTION	QTY	PART #
5" CASTER WITH BRAKE	4	W-C5PHB
5" CASTER W/O BRAKE	2	W-C5PH
3/8" X 5" CARRIAGE BOLT	6	
3/8" X 16 TPI NYLOC NUT	6	

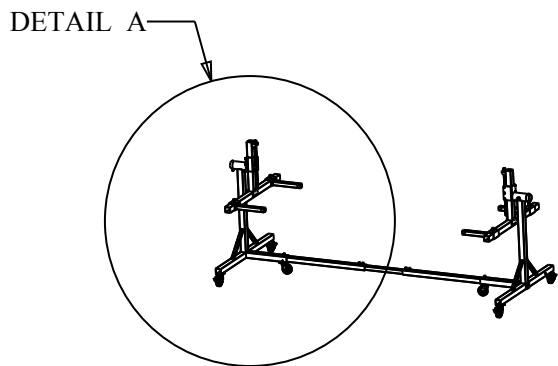
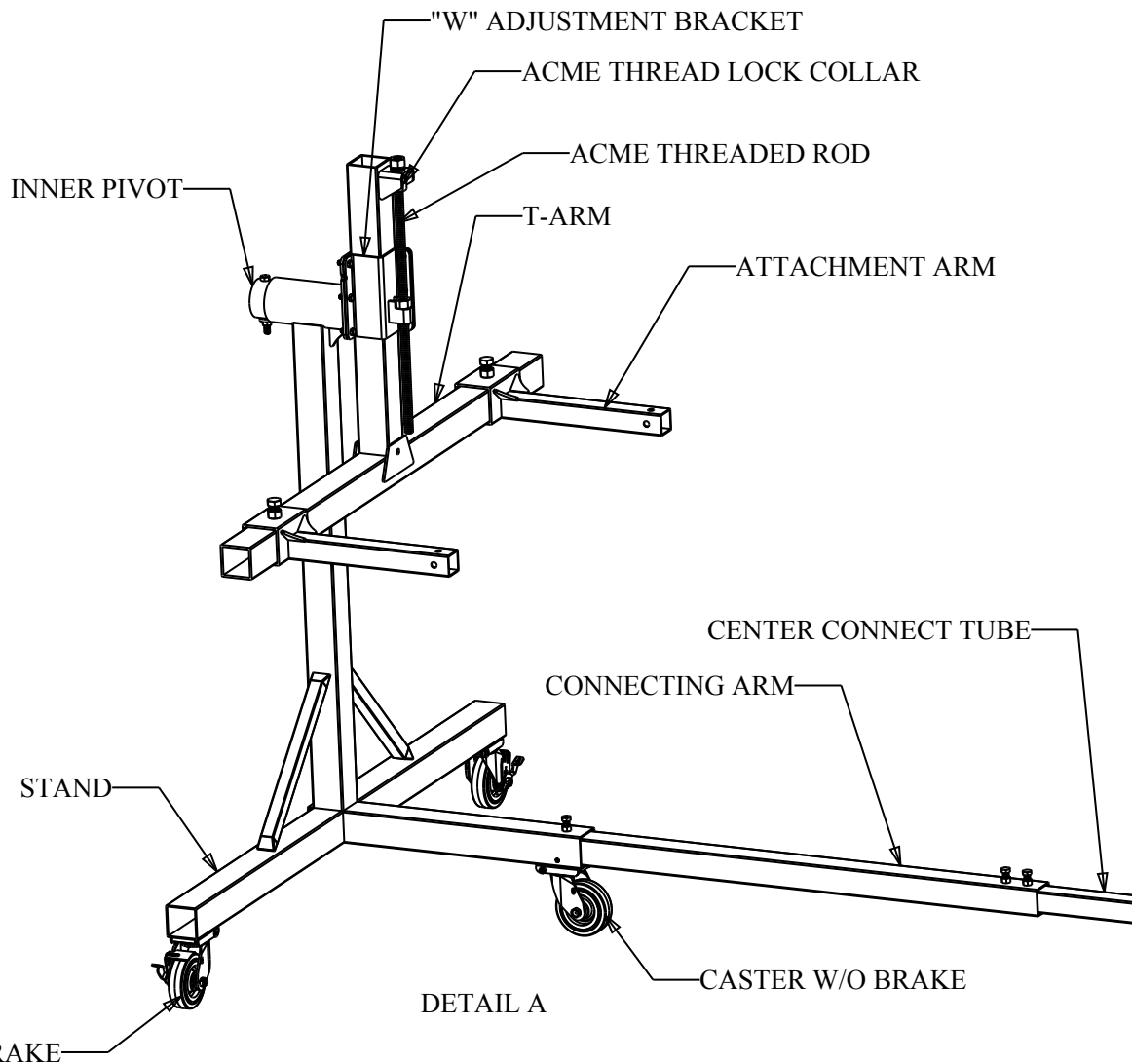

Auto Twirler[®] CLASSIC

For more information, please send inquiries to: info@autotwirler.com

Assembly Instructions

****ALL BOLTS SHOULD BE CHECKED EVERY TIME BEFORE PUTTING ANY WEIGHT ON ATTACHMENT ARMS****

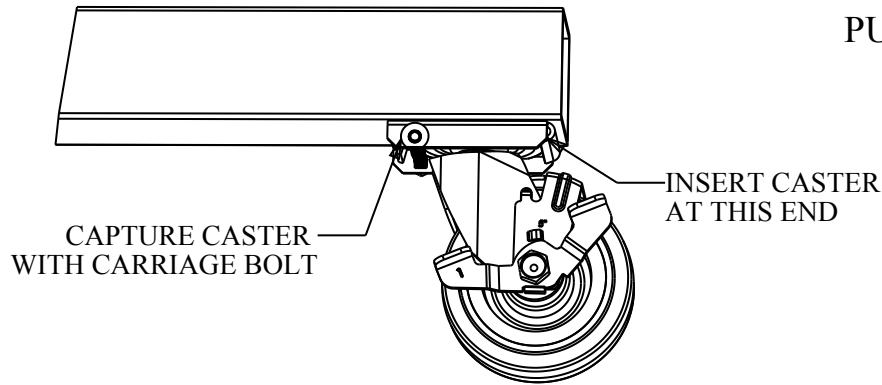

- 1.) Remove packing wrap and steel bands from pallet.
- 2.) Product is shipped with the center connect tube and 2 connecting arms inside the T-arms. To remove for assembly, loosen the bolts on the attachment arms, slide off the attachment arms, then slide out the center connect tube and 2 connecting arms.
- 3.) Slide the attachment arms back on the T-arm, and snug the bolts so they don't move.
- 4.) Next, remove the six casters with hardware from the box shipped with the rotisserie.
- 5.) The casters are placed as specified in the drawing on the previous page. To attach the casters, slide one end into the caster pad on the bottom of the stand, then seat the caster and insert a carriage bolt and fasten with a nut. Do not over-tighten.
- 6.) To connect the two stands together, assemble the connecting arms, and center connect tube as shown on the previous page.

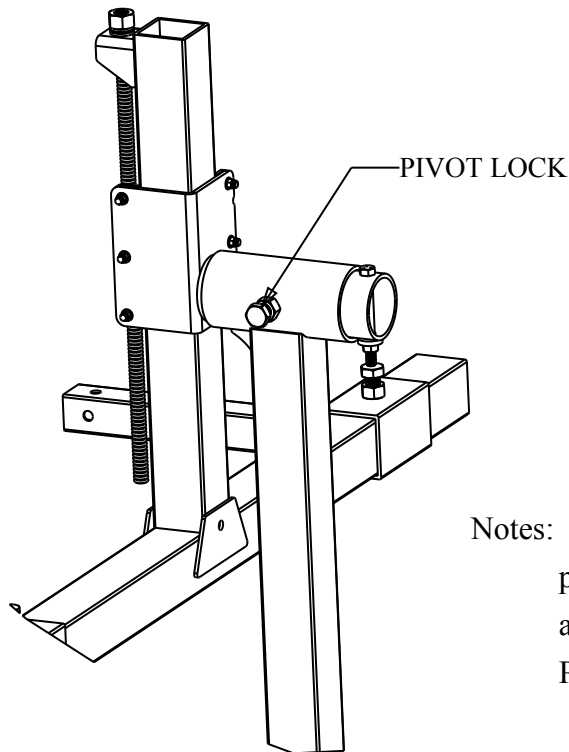

Notes: A dry lubricant can be applied to sliding parts to make movement easier. The pivot comes pre-greased, but periodic greasing every 3-6 months can be done by removing the pivot lock bolt and forcing grease inside the pivot housing.

Painting of the vertical member of the T-Arm can make adjustment more difficult.

*** NOTICE ***

This is not a toy. Improper use could result in property damage, injury, or even loss of life. Please read instructions carefully before you begin putting your vehicle on the AutoTwirler. Mounting your vehicle and finding the center of gravity will take some time. Please do not rush thru this process. If you have any questions, please contact us.

While AutoTwirler goes thru extensive measures and trials prior to selling our products to ensure they are safe, no liability can be accepted by the manufacturer, its distributors, or dealers when unauthorized modifications have been made to any component or the operating instructions were not observed. Manufacturer reserves the right to make changes in specifications, design, materials and manufacturing at any time without notification.

Lifting the Body off the Frame using the AutoTwirler CLASSIC (Optional)

There are many methods to remove the body from the frame, albeit with a hoist, a 2 post lift, etc., but if these pieces of equipment are not available to you, you can use the AutoTwirler CLASSIC to lift the body off the frame.

- 1.) Remove the casters from two towers to prevent them from rolling. Remove the bolt on the center leg.
- 2.) Lock down the pivot to prevent it from rotating.
- 3.) Push the mounting arms all the way up under the rockers on the side of the car, near the center as much as possible. Get them as far in as possible. If the frame is close to the edge of the car body, you may need to jack the body up to insert the mounting arms between the frame and the body.
- 4.) Extra support can be gained by connecting the two towers together with additional tubing.
- 5.) Slowly jack up each side of the car body. Keep the body level. Some bodies may be heavy in the rear and may require extra support to remain level. Additional equipment may be required to stabilize the rear.
- 6.) Roll the chassis forward, out from under the body. If the rear tires hit the center leg on the towers, use a floor jack to raise the differential enough to clear the tubing.
- 7.) Lower the body down onto jack stands, a cart, or blocks which are at least 20" high. AutoTwirler manufactures several options for this operation, like our standard body cart, body cart plus or heavy duty jack stands.
- 8.) Re-assemble the casters on the AutoTwirler CLASSIC towers. Insert the bolt back into the center leg.



Mounting Instructions

1. Before mounting the car body, you **MUST** identify the mounting method or mounting location. We can offer suggestions, but the ultimate decision is yours. It must be a strong enough mount to hold the weight.
 - a. On full frame cars, you can often mount to the body mounts.
 - b. For Ford and Mopar Uni-bodies, the front mounts are on the side of the frame rails where the bumper brackets are mounted. The rear can be mounted at the bumper mount using AutoTwirler Uni-plate Brackets or at the leaf spring mount using an AutoTwirler Leaf Spring Bracket.
 - c. For Chevy Uni-bodies, the front mounts at the firewall where the subframe comes off using AutoTwirler Mounting Arms. The rear can be mounted at the bumper mount using AutoTwirler Uni-plate Brackets or at the leaf spring mount using an AutoTwirler Leaf Spring Bracket. You will have to clear the rear valence.

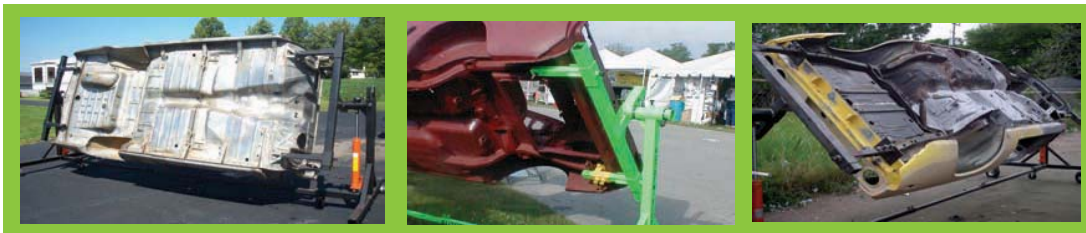

2. **MAKE SURE THE MOUNTING POINTS YOU HAVE CHOSEN ARE STRUCTURALLY SOUND.** If not, you will need to repair, replace, or support the mounting location before mounting it to the rotisserie.
3. With the vehicle on jack stands, or cart, other elevated structure, at least 18" off the ground, center the AutoTwirler CLASSIC tower to the front and rear of the car. Measure the same distance left to right from the center of the swing arm to each mounting arm. Most cars are symmetrical left to right, but if your car is heavier on one side versus the other, you may need to offset the unit to the heavier side.
4. Mount the AutoTwirler mounting arms or accessory brackets to your car body. See Step 1 for suggestions on mounting locations and methods. Tighten all bolts on all mounting locations and where the mounting arm is attached to the swing arm. Do not overtighten the mounting arm.
5. Insert the center connecting tubes into the center legs of each tower. Make sure each tower, or base, is perpendicular to the floor and parallel to each other. Tighten the bolts on the center tubing. Do not overtighten.



6. Double check all mounting locations and the tightness of **ALL** bolts.
** A loose connection could lead to damage or injury, so do not get in a hurry here. **
7. Start lifting the car body using the hydraulic jacks. One person on each end is ideal to keep the car level. If only one person is available, lift one end 3" and alternate back and forth until at the desired working height. Remove all previously used jack stands, or carts, that the car body was sitting on originally.

Balancing Instructions

1. Always make adjustments to the balancing system with the swing arm in the upright position. Follow instructions carefully to prevent the body from becoming dangerously top heavy.

CAUTION: If the car body is turned upside down prior to tightening the 2 pinch bolts on both ends, the body will fall. Always tighten the 2 pinch bolts prior to rotation.

2. Make sure the height adjustment is high enough so the car will clear the center when fully rotated. For safety sake, start on the top hole. Always watch the clearance when rotating the car for the first time.

3. Start with the swing arm in the lowest position, making the car bottom-heavy.

4. Push on the swing arm to test the balance. The car should swing back and forth. If it stays in a vertical position, it is balanced. Stop. If it is too heavy to push to a vertical position, it is still bottom heavy. Move to step 5.

5. Put full tension on the Acme Rod, pushing down against steel cup below it.

6. Once the weight of the car is carried by the acme thread, as a screw jack, loosen the pinch bolts.

7. Rotate the Acme Rod, keeping it in the cup, to raise the swing arm up thru the tubular collar at the end of the pivot. This will therefore raise the center of mass of the car body, making it easier to rotate. Repeat on each end by going back and forth, or having one person on each end.

8. As you raise the car body, you can swing the body back and forth, like a pendulum. The more you raise it, the more pendulum action you will get. **DO NOT TAKE IT PAST VERTICAL PRIOR TO TIGHTENING THE PINCH BOLTS.**

9. If you can push the body to a vertical position with ease, it is balanced. Bring it back down and tighten all 4 pinch bolts (2 on each end).

10. Once the pinch bolts are tightened, and you double check the clearance on the center tubing, rotate the body 360 degrees. Lock it in place with the bolt on top of the pivot.



AutoTwirler[®]

675 N 600 W STE 2, LOGAN UTAH, 84321

email: info@autotwirler.com website: www.autotwirler.com
3/23/15

AutoTwirler®

Painting Guide

Painting Recommendations

- 1.) Clean all of the tubing to remove the protective oils.
- 2.) In the case of the PRO model (shown), it is not recommended to disassemble the pivot because it contains ball bearings. The STANDARD, CLASSIC or ELITE models are steel on steel, but each pivot is greased.
- 3.) Note the Powder Coated Unit to the right. We do not paint, and we recommend that you do not paint, the upright Tower or the Vertical member of the Swing Arm. Both of these require tubing or clamps to slide over the top of them. Paint provides some grip, which will cause the outer piece to dig in and bind on the tubing.

In order to prevent binding, and provide the smoothest operation, recommend you lubricate these 2 posts and the inside of the collar or clamp that slides over them with (a) lithium grease, (b) silicon lubricant, (c) furniture paste wax, (d) or even Vaseline, instead of painting them.

- 4.) The bolts are black oxide. Paint the threads of the bolts, the nuts, or the acme rod will cause them to bind up. Do not paint them.

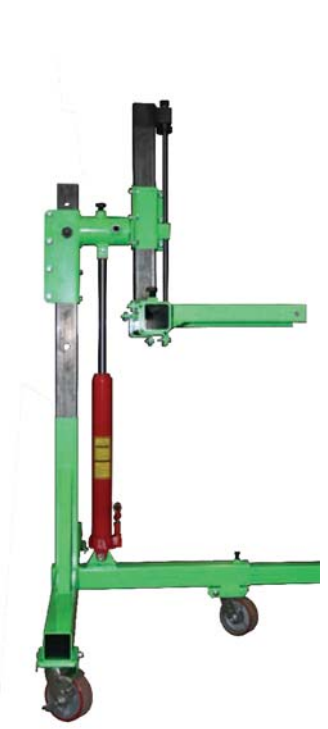

AutoTwirler®

Limited Warranty

- 1.) Every AutoTwirler has a 1 year warranty on the jacks & casters and a 5 year warranty on steel components against manufacturing defects from the date of purchase.
- 2.) This warranty does not cover mis-use, not following instructions, or items that have been altered in any way. Replacement items are available, at a cost, if needed.
- 3.) This warranty is not transferable and must have proof of purchase.
- 4.) If you purchased your unit thru a dealer, mail order, or other provider, we highly recommend that you register your product with us by mailing, or faxing, your receipt or calling us with your name, address, phone and date of purchase. If you purchased your unit directly from us, your information should already be in our customer database.