

10KACD & 9KACD

Installation & Operation Manual

10,000 Lbs. /9,000Lbs. Capacity Symmetric / Asymmetric Two-Post Lift

**READ THIS MANUAL BEFORE INSTALLING OR OPERATING THE LIFT.
INSPECT THE LIFT UPON DELIVERY. NOTE ANY DAMAGE ON DELIVERY RECEIPT.**

CONTENTS

Product Description..... 3

Terms and Conditions 4-6

 Risk of Loss / Freight / Shipping..... 4

 Delivery, Unloading and Freight Damage 4

 Installation..... 5

 Warranties 5

 Returns and Replacements 6

Shipping and Damage Claims..... 6

Introduction..... 7

Unpacking..... 8

Before Installation..... 9

Shipment Checklist..... 9

Owner/Employer Responsibilities..... 10

Important Safety Instructions..... 11

Preparation..... 12

Structural Performance..... 12

 Power Unit..... 12-13

 Control System 13

 Installation Instructions 13-19

Groundwork Foundation Drawing 14

Pre-Operation..... 19

Operation 19

Lowering The Lift..... 21

Safety Procedures..... 21

Maintenance Schedule..... 21-23

Trouble Shooting..... 24-26

Specifications..... 27

 Power Unit..... 28

 Symmetric Unit Measurements 29

Exploded Drawings..... 30-52

Overhead Cut off wiring Instructions 53-54

PLEASE READ THE ENTIRE MANUAL BEFORE ANY INSTALLATION AND OPERATION OF LIFT.

PRODUCT DESCRIPTION

The 10K ACD/9K ACD 2-post,10,000 lbs/9,000lbs.capacity overhead lifts.

This lift is a10,000 lbs/9,000lbs.capacity,2-post lift.The safety latch system is very similar to an extension ladder.

The safety latch is in contact with the rack as the lift ascends and drops into place as the lift rises.The safety latch engages in rack in 3"(76mm)increments,starting at about 16"(406mm)from the ground. The locking latch must be manually disengaged for the lift to descend.The latch is released by pulling the release cable raising the latch up off the latch rack.Once the raise button is pressed,the latch will automatically re-engage after approximately 3"(76mm)of travel.

Please read the safety procedures and operation instructions in this manual before operating the lift. Proper installation is very important.Keepthisoperationmanualnearthemachineatalltimes.Make sureALLUSERSreadandfullyunderstandthismanual.Tominimizethechanceofmakinganerrorin installation,pleasereadthis manualcarefullybeforebeginning installation.Check with the building owner and/or architect's building plans when applicable.The lift should be installed on a relatively level floor with 4.25",3,000 PSI (207bar)concrete that has sufficiently cured for a minimum of 30 days.

This is a vehicle lift installation/operation manual and no attempt is made or implied herein to instruct the user in lifting methods particular to an individual application.Rather,the contents of this manual are intended as a basis for operation and maintenance of the unit as it stands alone or as it is intended and anticipated to be used in conjunction with other equipment.

Proper application of the equipment described herein is limited to the parameters detailed in the specifications and the uses set forth in the descriptive passages.Any other proposed application of this equipment should be documented and submitted in writing to BBA for review.The user assumes full responsibility for any equipment damage,personal injury,or alteration of the equipment described in this manual or any subsequent damages.

TERMS AND CONDITIONS

Please read these terms of service carefully.

These terms and conditions of sale ("Agreement") are applicable to any order placed by you (the "Customer") with and accepted by Best Buy Automotive (referred to herein as "BBA").

Risk of Loss / Freight / Shipping

All shipments are FOB the Best Buy Automotive warehouse, which means that ***ownerships of these goods transfers to the customer when they leave our dock***. We use common carriers that have a demonstrated history of timely deliveries and competitive freight rates for the benefit of our customer. Most of these carriers have restrictions on delivering to residential addresses and may require pick-up at freight terminal. There are additional fees for residential, limited access and remote delivery. There are additional fees for lift gate services and scheduled deliveries from the freight carriers.

For items advertised with "Free Shipping"; this applies only to shipments within the Continental United States (excludes Alaska, Hawaii, and Canada and Mexico). Free Freight does not apply to residential, limited access and remote delivery locations. Call the Best Buy Automotive sales department for a specific freight quote.

Delivery, Unloading and Freight Damage

Unloading: The customer is responsible for unloading the shipment from the carrier's truck. This may require a forklift and/or lift gate service. Please note that Lifts will require a forklift to unload and they cannot be unloaded using a lift gate vehicle. The Best Buy Automotive customer care team can advise you prior to shipping what will be needed to unload your shipment and the approximate weight of the shipment.

Tracking: While Best Buy Automotive will provide customers with an estimated time of delivery and tracking information, we can't provide a specific time, or schedule a time for that service. The customer can contact the freight carrier directly to schedule a delivery or check on freight delivery status.

Damages: Any charges or damages that may be incurred as a result of unloading from the carrier's truck is the customer's responsibility. Depending on your situation, it may be advantageous to have your products shipped to a freight terminal where the freight company's personnel can load it onto your trailer or truck. Please note that Lifts will require a fork lift to unload and they cannot be unloaded using a lift gate vehicle.

Upon delivery, it is very important that you inspect all of your products immediately. While we make every attempt to prevent freight damage by properly packaging your order, sometimes damage occurs in transit. For your protection, it is imperative that you note any and all damage you observe on the Delivery Receipt (Bill of Lading) that the carrier will ask you to sign. This will establish your right to file a claim against the freight carrier for this damage. If there are notable shipping damages to your equipment at time of delivery, we advise that you deny the shipment and note "Arrived Damaged" on

the Bill of Lading. We also advise that you take photos of the damage for your freight claim with the freight carrier. The carrier will then return the damaged equipment to their warehouse for inspection. You are then advised to contact Best Buy Automotive concerning your damaged shipment.

If there are concealed damages after the carrier has departed (something you hadn't noted on your initial inspection), this should be reported to the freight company **within three days of delivery** in order to preserve your right to file a claim. It is the customer's responsibility to file damage claims against the freight company. Best Buy Automotive customer care team is here to assist with the claim if we are contacted within the 3-day windows.

Shortages: Should you discover any shortages/missing parts, we ask that they be reported to Best Buy Automotive's customer service **within 3 days of delivery**

Best Buy Automotive (referred to herein as "BBA")

Installation

BBA has a nationwide network of independent installers that we can recommend for your Equipment. These installers do not work for BBA. Please call BBA to find an installer in your area. The contract you enter into with the independent installer is outside the relationship you have with BBA and we are not responsible for issues or damages that you may incur with the independent installer.

Warranties

Best Buy Automotive is warranted to be free of defects in material and/or workmanship for a period not exceeding one year. Best Buy Automotive will replace parts only, under this warranty if in BBA's view there is a defect in material or workmanship. The end user will be responsible to pay shipping of suspected product to the distributor from which they bought the product. The original distributor will arrange for all warranty parts and will pay return shipping, if the product proves to be defective.

This warranty does not cover normal wear, abuse, misuse, shipping damage or damage from lack of required maintenance. This warranty is exclusive and in lieu of all other warranties, expressed or implied. Under no circumstances will BBA be liable for consequential or incidental damages. Model and serial numbers must be provided with original proof of purchase, confirming date sold, to original end user, before any claim under this warranty will be considered by BBA. To view more details on our Terms of Sale, please visit www.BestBuyAutomotive.com.

Exclusions:

This warranty will not apply to any machine:

Which has not been operated or maintained according to specifications

Which has been abused, misused, altered, or improperly maintained

Which has been improperly installed or assembled

Other limitations:

This warranty does not cover:

Parts needed for normal maintenance

Wear parts, which include but are not limited to: cables, hoses, slider blocks, and rubber pads

On-site labor

Returns and Replacements

In the event that you suspect you have a defective part or product ("part"), please contact our customer care department immediately by calling 1-880-647-7883, or by Emailing:

BBA. Please include photos and video of the defective equipment for your claim

If we believe that you have received a defective part BBA will provide you with a return authorization ("RA") number and schedule a time to have your equipment picked up. It is the customer's responsibility to package the equipment for return shipment in sufficient packaging to prevent damage during return. Please note the BBA RA number on the packaging.

Upon receiving and inspecting the defective part, BBA will provide a replacement part, free of charge

,
to the customer. If the customer wishes to have the warranty replacement shipped to them prior to the return of the defective product, the customer must pay for the replacement product at shipping. BBA will issue the Customer a refund upon receiving the defective product.

In the event the part is determined to not be defective, it will be subject to a minimum restocking fee of 20% and the return freight. Credit for warranty returns to third party vendors will be subject to their return policy. All returns must be authorized prior to shipping. Contact BBA's customer care department for instructions and a return authorization number, which must be issued prior to any return. Customers may return any unused stock item in the original packaging within 30 days of purchase subject to a 20% restocking fee. All freight charges related to the original shipment and the return will be the responsibility of the customer.

INSPECT YOUR LIFT UPON DELIVERY. NOTE ANY DAMAGE ON DELIVERY RECEIPT.

SHIPPING AND DAMAGE CLAIMS

All shipments must be inspected immediately upon receipt. For your protection, any external damage must be noted on the bill of lading at the time of delivery in order to qualify for a claim against the freight carrier.

Concealed damage must be reported to the freight company within three (3) days of delivery. It is the customer's responsibility to file for damage claims against the freight company. Best Buy Automotive is not responsible for loss or damages caused by shipping.

Shortages or missing parts must be reported to Best Buy Automotive Customer Service (1-800-647-7883) within three (3) days of delivery.

INTRODUCTION

Thank you for your purchase.

Your lift is the result of decades of research, testing, and development; and represents the most advanced technology on the market.

The care with which you maintain and operate your lift will directly affect its overall performance and longevity.

BE SAFE.

Your lift was designed and built with safety in mind. However, safety relies on proper training and thoughtful use on the part of the operator. DO NOT operate or repair this equipment without reading this manual and the important safety instructions shown inside.

Keep these instructions accessible, and make sure that ALL USERS read this manual.

**PLEASE READ THIS MANUAL IN ITS ENTIRETY BEFORE
INSTALLING OR OPERATING THIS LIFT.**

RECORD THE MODEL NUMBER AND THE SERIAL NUMBER

This information is located on the main post of your lift.

Model Number: _____

Serial Number: _____

Manufacturing Date: _____

**THIS INFORMATION WILL BE REQUIRED
SHOULD YOU EVER NEED TO CALL IN FOR
PARTS OR TECHNICAL ASSISTANCE**

For parts assistance, please call: **1-800-647-7883**

WARNING:

Failure to follow the unpacking and assembly directions may cause personal injury and/or impair the operation of this machine.

PLEASE READ THOROUGHLY.

UNPACKING

1. Your lift comes packaged as a single unit. A fork-lift, floor-jack or other heavy-lifting equipment may be necessary to separate the components. Exercise caution when disassembling the packaged lift, as shifting may have occurred during shipping.
2. Carefully remove the shipping bands and brackets from the lift. Check for any obvious shipping damage. Remember to report any shipping damage to the carrier and make a notation on the delivery receipt. Save all bolts, nuts and washers securing the shipping brackets, as these may be used in the assembly of the lift.
3. The unit is composed of several main components.
4. An accessory box is included with the lift and contains smaller components.
5. Unstrap and remove the power unit box from the packaged lift. Literature such as the installation manual, warranty card, and serial number plate is included inside this box. Inspect the power unit and note any possible shipping damage on the shipping bill.

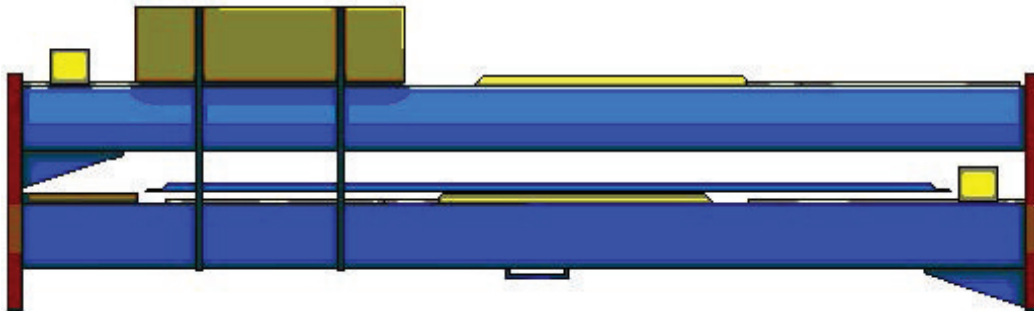

Shipments must be inspected immediately upon receipt.

External damage must be noted on the bill of lading.

Concealed damages must be reported to the freight company within three days of delivery.

Shortages must be reported to Best Buy Automotive within three days of delivery:

Best Buy Automotive

BEFORE INSTALLATION

The following tools and equipment are needed:

- 3/4"Concrete drill
- Hammer(14 oz.min.)
- Level (4-ft minimum)
- Inch &Metric combination wrench set,
3/8"to 1 1/8"(10 to 32 mm)
- Ratchet &Sockets sized as above
- Inch &metric hex key set,
3/32"to 3/8"(2 to 10 mm)
- 10"Adjustable wrench
- 14"Pipe wrench
- Needle nose pliers
- Flat pry bar(for installing shims)
- Chalk Line
- Tape Measure 25'
- Locking Pliers(vice grips)
- AW 32 Hydraulic Oil

This lift requires 220VAC 20A max.Fuse at 60 Hz single-phase.Wiring must meet code.Please ensure that all wiring is capable of handling the loads and voltages applicable.The wiring of this device must be done only by a qualified electrician to ensure that you meet your local electrical code.

SHIPMENT CHECKLIST

- 4-Arms with lift pads (2 long symmetrical and 2 short three stage)
- 4-Arm Pins(1-1/2"diameter)
- 4-Hydraulic Hoses(1 long,3 short)
- 1-Set of 4 Drop-in Extensions(4 long,)
- 1-Overhead Cross Bar(complete with bolts)
- 2-Columns(complete with rams,carriages and cables)
- 1-Small Cable (loose,for safety release)
- 2-Safety Side Covers
- 10-Anchor Bolts
- 1-Hydraulic Power Pack
- 1-Document Envelope
- 1-Electric limit switch/cable,bar and brackets(for overhead travel limit



OWNER/EMPLOYER RESPONSIBILITIES

The owner/employer is responsible for proper installation and maintenance of this lift according to this manual. The owner/employer of the lift is responsible for acquiring locally required authorizations such as permits, including electrical and seismic permits. Seismic permits will require the owner/employer to contract a locally-licensed professional engineer or engineering firm that is knowledgeable about local codes and equipment anchoring.

The owner/employer shall ensure that lift operators are qualified and that they are trained in the safe use and operation of the lift using the lift manufacturer's operating instruction.

The owner/employer shall establish procedures to periodically inspect the lift in accordance the lift manufacturer's instructions ***Safety Requirements for Operation, Inspection and Maintenance***. The owner/employer shall ensure that the lift inspectors are qualified and that they are adequately trained in the inspection of the lift.

The owner/employer shall establish procedures to periodically maintain the lift in accordance the lift manufacturer's instructions . The owner/employer shall ensure that the lift maintenance personnel are qualified and that they are adequately trained in the maintenance of the lift .
The owner/employer shall maintain records of periodic maintenance.

The owner/employer shall display the lift manufacturer's operating instructions in a conspicuous location in the lift area convenient to the operator.

The owner/employer shall not modify the lift in any manner with prior written consent of the manufacturer.

IMPORTANT SAFETY INSTRUCTIONS

READ THESE SAFETY INSTRUCTIONS THOROUGHLY

1. Read and understand all operation and safety warning procedures before operating the lift.
2. Keep hands and feet clear. Remove hands and feet from any moving parts. Keep feet clear of lift when lowering. Avoid pinch points.
3. Keep work area clean. Cluttered work areas invite injuries. Consider work area environment. Do not expose equipment to rain. Do not use in damp or wet locations. Keep area well lit.
4. Only trained personnel should operate this lift. All non-trained personnel should be kept away from the work area. Never let non-trained personnel come in contact with or operate the lift.
5. Use the lift correctly. Never use lifting adapters other than those provided by the manufacturer, in any manner other than intended. Only use the vehicle manufacturer's recommended lift points.
6. Do not override self-closing manuals. Do not overload the lift. Load capacity is indicated on lift nameplate.
7. Remain clear of lift when raising or lowering vehicle. Clear area if vehicle is in danger of falling.
8. After positioning the vehicle, apply the parking break. Make sure the vehicle doors are closed during raising and lowering cycles. Do not allow anyone on the lift or inside the raised vehicle.
9. Always ensure that the safeties are engaged before any attempt is made to work on or near vehicle. After raising the vehicle briefly, stop and check the pad adapters for secure contact. Always lift vehicle using all four adapters.
10. Use caution when removing or installing heavy components (center-of-gravity displacement).
11. Dress properly. Non-skid, steel-toe foot-wear and safety glasses is recommended when operating lift.
12. Guard against electric shock. This lift must be grounded while in use to protect the operator from electric shock. Never connect the ground wire to a live terminal. This is for ground only.
13. **DANGER:** The power unit used on this lift contains high voltage. Disconnect power at the receptacle before performing any electrical repairs. Secure plug so that it cannot be accidentally plugged in during service.
14. **WARNING:** Risk of explosion. This equipment has internal arcing or sparking parts which should not be exposed to flammable vapors. This machine should not be located in a recessed area or below floor level.
15. Maintain with care. Keep lift clean for better and safer performance. Follow manual for proper lubrication and maintenance instructions. Keep control handles and/or buttons dry, clean and free from grease and oil. Protect all parts of the electrical equipment from humidity and moisture.
16. Carefully inspect the lift on a regular basis. Perform maintenance according to the maintenance schedule.
17. Check for damaged parts. Check alignment of moving parts, breakage of parts or any condition that may affect its operation. Do not use lift if any component is broken or damaged.
18. Never remove safety related components from the lift. Do not use the lift if safety related components are damaged or missing.
19. Stay alert. Watch what you are doing. Use common sense. Be aware.

Working temperatures:

1. Ambient temperature: 40-105° Fahrenheit
2. Humidity: 30-95%
3. Transportation/storage temperature: 77-131° Fahrenheit, not exceeding 24 hours at up to 158° F
4. Installation altitude max: 3280 feet (1000m)

PREPARATION

The installation of this lift is relatively simple and can be accomplished by two (2) people in a few hours. This lift is not intended for outdoor use. **If it is installed outdoors, your nationwide warranty is null and void.**

Model # -10K ACD /9K ACD

Surface-mounted two-post overhead *symmetrical* and asymmetrical lift 10,000 lbs./9000lbs capacity.

STRUCTURAL PERFORMANCE

The main components are the towers, lifting carriages, swing arms, cylinders, cables and power unit. Arms and carriages have locking mechanisms for simple and safe operation.

Depressing the switch on the power unit raises the lift. Releasing the switch stops the lift. Lift should always be settled on the carriage locking mechanisms. To lower the lift, simply raise the carriages up off the locks, pull on the small ringed cables below both carriages to disengage the locks, and depress the lowering handle.

Arms rotate and telescope for easy use. Adapters are included for raising the height of the basepad at the end of the arm. Swing arm locks automatically engage as the carriages rise, and disengage once they are lowered to the floor.

POWER UNIT

This lift requires 220VAC 20A max. Fuse at 60 Hz single-phase. Wiring must meet code. Please ensure that all wiring is capable of handling the loads and voltages applicable. The wiring of this device must be done only by a qualified electrician to ensure that you meet your local electrical code.

The hydraulic system uses a hydraulic power unit, a system that has a manual regulator function, rotating the mediate relief valve screws. Can regulate mediation system pressure.

NOTE: The pressure of the system is adjusted before purchase, the user can not adjust personally. After starting the motor, the cylinder moves to achieve lift. After motor stall, the one-way valve and

the unloading valve seal the machine to maintain the original height of tank will not drop.Press the unloading valve handle to lower the lift.

CONTROL SYSTEM

Connect the power supply,press power button,when desired height has been reached,release the button to stop the lift.Press the unloading valve handle to lower the lift.At the same time the safety lock in the condition of unlocking.Release the handle to stop the lift.

When the desired height has been reached,let the lift fall down without release the safety lock.This will ensure the lock engages,preventing a sudden drop.When working,implementation of the latch is crucial.Do not operate the lift if the safety lock does not engage.

INSTALLATION INSTRUCTIONS

PLEASE READ INSTRUCTIONS BEFORE OPERATING THE LIFT.

STEP ONE-UNPACKING

- 1.Cut the metal banding with an appropriate tool.CAUTION:When cutting bands.Use gloves and eye protection.The tension released may cause the banding to spring in any direction cutting you or those around you.
- 2.Carefully remove the plastic packaging material around the lift.
- 3.Remove the hydraulic power unit.Store this unit on its side until needed.
- 4.Lift cross bar off and remove plastic wrap,being careful not to damage the limit switch.
- 5.Remove loose components from top column,and lay out on the floor close by.
- 6.Using a lifting device,support the top column,unbolt and remove the shipping brackets from this column only.Lift column off and stand upright.
- 7.Remove loose components from bottom column and layout on the floor near by.
- 8.Ensure all components are accounted for.
- 9.Using a lifting device support the bottom column,unbolt and remove the shipping brackets from this column stand upright.
- 10.After installation,deliver this manual,all other materials and instruction manuals furnished with this lift to the owner/employer/user.

STEP TWO-SITE SELECTION

- 1.This equipment is intended for indoor use only,with an operating temperature range of 40-105°F (5-40°C).
- 2.Locate lift according to architectural drawing if available.
- 3.12-feet is the minimum height requirement to install and service this lift.
- 4.The space above the lift installation should be free of overhead obstructions such as wiring,cables, buss boxes,building supports,heaters,duct work etc.
- 5.Stand the lift columns up in the space where they will be installed and ensure that there is enough working space around the lift.See step three-Site Layout,for column spacing.
- 6.Visually inspect the concrete in the lift installation area for cracks,flaking or spalled concrete.Do *not install lift columns within 6"of an expansion joint or the edge of the concrete slab.*

GROUNDWORK FOUNDATION DRAWING

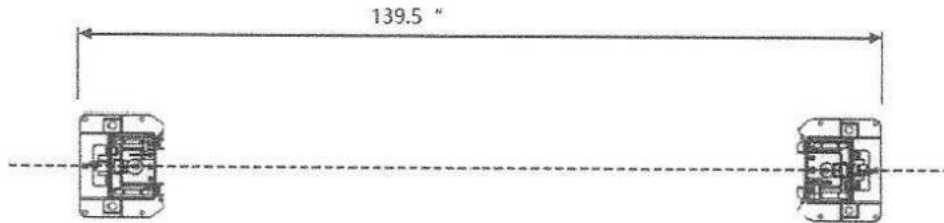

Figure 1 Column Layout

7. This lift must be installed on concrete, where the concrete is at least 4.25" thick, has a compressive strength of 3000 PSI and has been cured for a minimum of 30 days. Do not install this lift on any surface other than concrete.
8. The slope of the floor must not exceed 1-inch in ten feet.
9. If the floor is of questionable quality or has excessive slope, pour a new, level concrete pad that will meet those specifications.

STEP THREE-SITE LAYOUT

1. Determine the entry end of the bay area and locate the lift centerline at least 96" for a symmetrical lift, from any obstruction on either side.
2. Use a chalk line to layout the centerline of the bay parallel to the entry direction of the vehicle.
3. Using the chalk line again to layout a line 90° to the center line at least 10' for a symmetrical lift, from the nearest obstruction in front of the columns.
4. Move the power side column into place over the 90° chalk line. On a symmetrical lift, align the column center to the chalk line as shown in Figure 1.
5. Move the other column into place once again. On a symmetrical lift, align the column center to the chalk line as shown in Figure 1.
6. Check all dimensions and the squareness of lines before proceeding to the next step.

STEP FOUR-MOUNTING THE COLUMNS

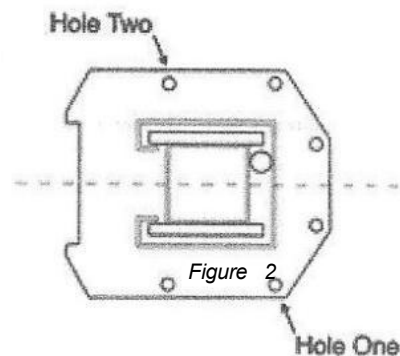

1. Starting with the power side column, use the base plate on the column as a guide and drill each hole in the concrete with the rotary hammer drill 3/4in bit, drill at least 6" deep.

Please refer to the anchor bolt manufacture website for recommended values. To assure full holding power, do not ream the hole or allow drill to wobble.

After drilling, remove dust thoroughly from each hole using compressed air and/or wire brush. Make certain that the column remains aligned with the chalk line during this process.

2. Start at Hole 1 and 2, as shown in figure 2, assemble the washers and nuts on the anchors then tap into each hole with a hammer until the washer rests against the base plate. Be sure that if shimming is required that enough threads are left exposed.

If shimming is required, insert the shims as necessary under the base plate so that when the anchor bolts are tightened, the columns will be plumb; With the shims and anchor bolts in place, tighten by securing the nut to the base. DO NOT use an impact wrench for this procedure.

If anchors do not tighten to 150 ft-lb installation torque, replace the concrete under each column base with a 4' x 4' x 12" thick 3000 PSI minimum concrete pad keyed under and flush with the top of existing floor. Allow concrete to cure before installing lifts and anchors (typically 2 to 3 weeks).

3. Install & tighten the overhead beam (attach limit switch & limit switch bar before)

With the other column standing in place, (Do not drill holes at this time), use a lifting device to raise the overhead cross bar and place into position on the top of the two columns with the open channel facing up. Using the bolts provided, screw in cross bar but do not tighten bolts at this time.

4. Measure the distance between the closest corners of the columns as shown in Figure 3. The distance between the top and bottom of the columns at this point must be the same. Adjust the loose column until the distance between the two columns is the same top and bottom (Parallel), as shown in Figure 4. Check that the locator marks of the loose column are still aligned with the chalk line.

5. Before drilling the concrete for the other column check all dimensions and locations. Repeat steps 1-2 and anchor the other column. Make sure the columns are square and plumb.

6. Tighten the crossbar bolts.

7. Tighten anchors, using shims if needed plumb the post in the forward backward direction.

Re-check all anchors.

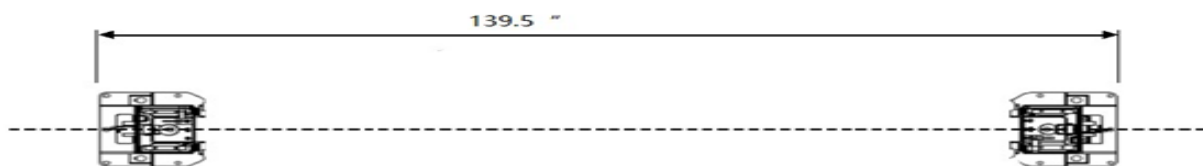

Figure 3 Column Spacing

STEP FIVE-CONNECTING THE SYNCHRONIZING CABLES

1. Pull the cables out of the columns, leaving them attached to the carriages

2. Raise each carriage by lifting them manually to a safety stop about 24" up. Ensure the safety locks are fully engaged and that both carriages are at the same height before proceeding. The carriages

should be within 1 / 4 "of height while sitting on the stops.

3.Route the end of the cable straight up through the column and close to the pulley on the cable side of the column.At this time remove this pulley from its mount and place the cable over it, replace the pulley back in the mounting.Now route the cable through the cross bar to the pulley on the other column.Remove and place the cable over this pulley as above.Route the cable down the column.

4.Install the second cable in the same way ensuring that both cables are not twisted,rubbing or otherwise distorted or jammed.

5.Attach each cable to its respective carriage;using one nut hand tightened.

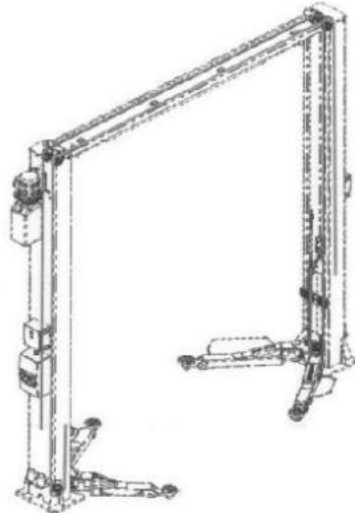

6.Re-check cable routing to ensure that the cables are not bound anywhere and that both cables are parallel above and below the carriages as well as through the cross bar.If adjustment is needed, loosen the cable and correct the misalignment.

7.Tighten both cables until they are taut,like the string on a musical instrument

8.Check that both carriages are still on the safety stops and that both cables have equal tension.

If one carriage is off a stop loosen the cable on this carriage or tighten the cable on the opposite carriage.

9.Check the level between the two carriages,shim the low column as needed.

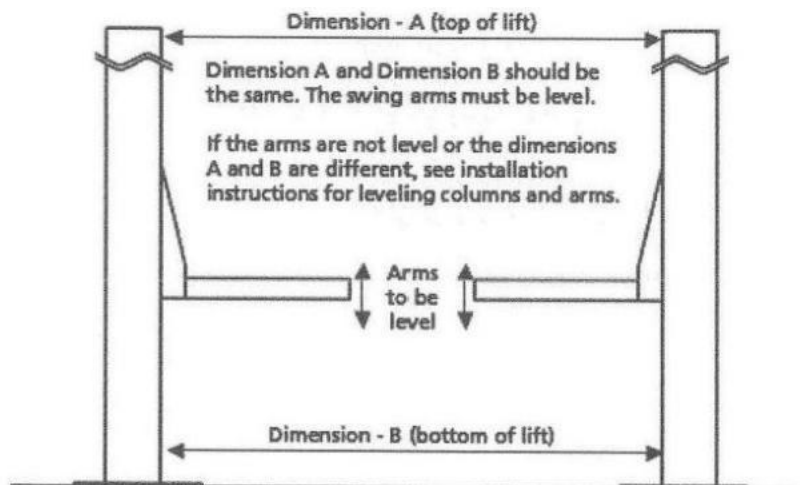

Figure 4 Column Squaring and Arm Leveling

STEP SIX-MOUNTING THE POWER PACK

1. Attach the power pack to the power side column using the supplied bolts and nuts.The reservoir should be below the motor.

2.Fill the reservoir only with hydraulic fluid rated SAE Grade 10,ISO grade AW32 hydraulic oil(3.5 gallons).AW32 can be purchased at your local auto store.

WARNING:DO NOT USE DEXRON,AUTOMATIC TRANSMISSION FLUID, TRACTOR OIL,OR JACK OIL.

- 3.Please ensure the oil is not contaminated and that a very clean funnel is used.NOTE:The main cause of premature pump failure is dirty oil

STEP SEVEN-CONNECTING THE HYDRAULIC HOSES

- 1.Feed the one of the long hoses down the column starting at the middle retaining loop above the carriage on the non-power pack column.Feed the hose down the Front of the column as shown in Figure 5.Ensure the cable passes on the front side of the safety stop and does not interfere

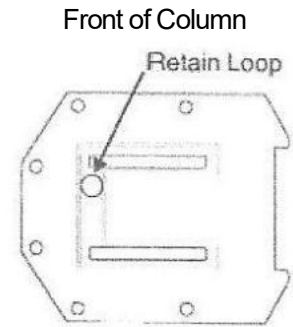

Figure 5

with the carriage travel path.Continue to feed the hose down until the end of the hose is visible at the bottom of the column.

- 2.Attach the hose to the elbow on the bottom of the ram.The top of this elbow should lean towards the front of the column.
- 3.Route the hose up the column to the center of the cross bar.
- 4.Repeat Steps 1-3 for the other column.
- 5.Cross the hose over to the back of the power pack column and down through all retaining rings avoiding the safety stops and carriage travel.
- 6.Attach the hose to the tee at the Power Unit and attach the mid size hose to the lower part of to down to the cylinder elbow.
- 7.Attach the short hose to the tee as well and connect other end to power pack.
- 8.The maximum operating pressure for the power pack,hoses and fittings is 2450 PSI.

STEP EIGHT-INSTALLING THE ARMS

- 1.Grease both pivot pinholes in each carriage and all four swing-arms before installing the arms.
- 2.Put a small amount of grease around the end of the pin opposite the head.
- 3.Slide the arm into position and insert pin down from the top.The pin is fully seated when the pinhead is flush to the top of the carriage plate.
- 4.Repeat steps 2-4 for all four arms.
- 5.The arms are trip hazards.Caution should be heeded when working around the arms if the arms are below waist height.
- 6.The arm restraints should disengage automatically when the carriage is within V_2 "of the lowest position.Raising the carriages will engage the arm restraints.The arms may require slight rotation to allow the restraint gears to engage.
- 7.Test to arm restraints by moderately pushing on the arms when the carriage is raised.This safety device is important to keep the vehicle from moving during the lifting process or while working on the vehicle.

STEP NINE-INSTALLING THE OVERHEAD TRAVEL LIMIT SWITCH

- 1.Mount bar mount bracket with the assembled limit switch on the power-side column,slot toward the center of the lift.
- 2.Mount the other bar mount bracket,installing the floating bar.
- 3.Route the cable through the cable guides provided.
- 4.Wire the limit switch in series with the power by connecting to the tw
- 5.Verify that lifting the floating bar while raising the lift terminates the lifting.

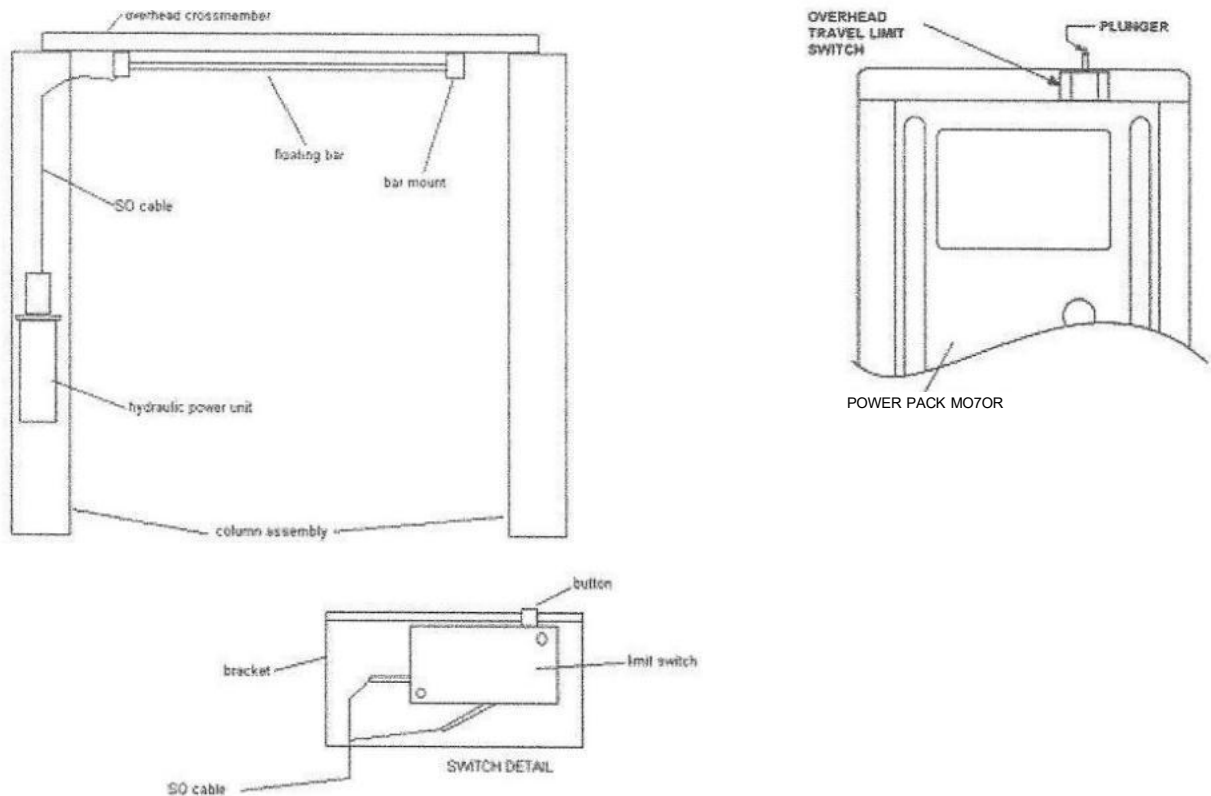

Figure 6 Travel Limit Switch

6.If necessary,adjust the Jimit.switch (see detail below)so that the switch engages properly.The Switch is mounted on slots that allow vertical adjustment.

STEP TEN-WIRE POWER PACK

- 1.The wiring of this device must be done only by a qualified electrician.
- 2.This unit requires 208 to 230 volt,1-phase power with a 20-30 amp fuse or breaker.
- 3.Do not run the power unit without oil.
- 4.Run power pack until carriages move up a small amount.This could take some time as the lines and rams need to be filled with oil.
- 5.See Trouble-shooting section (page 23)if there are any problems with the power pack.

STEP ELEVEN-BLEEDING RAMS

- 1.Raise the lift so that the arms are about 18"off the floor.
- 2.Loosen the bleeder screw on the cylinder.
- 3.Allow the air to bleed from the cylinder.
- 4.Tighten the bleeder screw after all of the air has escaped.
- 5.Repeat for the main side cylinder.
- 6.Proceed with Step Twelve (below)installing release cable and then return to finish this step.
- 7.Raise carriage all the way up and down to ensure every thing clears and that all air is out of the rams.
- 8.Check for oil leaks.
- 9.Repeat steps 1-5 above if necessary

STEP TWELVE-INSTALLING RELEASE CABLE

1.From out

side the power side column route the cable under the wheel and attach to the release arm.2. Run the cable up the inside of the column over the small wheel on the outside of the overhead cross bar,across the cross bar over and down the non-power side column in the same way,and attach to the non-power side lock.

NOTE:Be careful not to wrap the lock release cable around the synchronizing cable or other obstruction that will hinder the free movement of the cable.

3.Adjust the cable at each lock to ensure contact and release on both sides.

4.Install the covers.

5.Run the carriages up and down several times to ensure smooth operation and that there is no interference.

6.Continue with item seven bleeding rams above (Step Eleven).

PRE-OPERATION

RAISING THE LIFT FOR THE FIRST TIME

1.Raise the lift,full stroke,at least twice,carefully watching and listening for any noise,binding, clunking,etc.to ensure smooth operation.

2.Load and raise the lift to full height,at least twice,with a typical vehicle being lifted at this site. Carefully watch and listen for any noise,binding,clunking,etc.to ensure smooth operation.

3.This lift is designed to raise typical vehicles,that is to say normal cars and light trucks,SUVs,etc.. It is not designed to lift over-sized vehicles like limousines,cube vans,RVs.Do not attempt to raise vehicles that are over weight or exceed the designed/advertised capacity of the lift.

OPERATION

1.Read and understand safety items in this manual.

2.Always lift a vehicle using the manufacturers lifting points.

3.Position vehicle centered between columns such that the center of gravity of the vehicle is back of column center line 29 inches as shown in Figure 8 for an asymmetrical lift,or on the center line of the columns as shown in Figure 11.

4.Adjust the swing arms to the vehicle manufactures lift points.

5.Use pad extensions if needed to keep vehicle level.

6.Raise lift by pushing button on the power pack until the pad contacts the vehicle.Check to see if all pads contact the vehicle at about the same time and are making contact at the recommended lift points.Lower lift and re-adjust swing arms if needed.See action#5(above)if a large difference in contact is seen.

7.Raise the vehicle a small amount and check to ensure the vehicle is secure on the lift pads and that

the vehicle is balanced.

8.Raise vehicle to the work height by pushing button on the power pack.

9.Lower onto safety stops by pushing the release lever on the power pack.

10.Always lower the lift onto the safety stops before working on,under or near the vehicle.

LOWERING THE LIFT

1. Ensure the area under the vehicle is clear of equipment, tools, personnel or other objects that may interfere with the vehicle when on the ground.
2. Raise the lift a small amount by pushing button on the power unit to clear the safety stops.
3. Release the safety locks.
4. Lower the vehicle by pushing the release lever on the power unit.
5. When lift is fully lowered, swing lift arms out from under the vehicle and remove pads and extensions if used.

Never drive over the lift arms or pads. Ensure the position of arms allows for the unobstructed exit of the vehicle.

SAFETY PROCEDURES

- Never allow unauthorized persons to operate lift. Thoroughly train new employees in the use and care of lift.
- CAUTION: The power unit operates at high pressure.
- Remove passengers before raising vehicle.
- If any problems are seen with the lift, do not use it until the problem(s) are fixed.
- Prohibit unauthorized persons from being in shop area while lift is in use.
- Total lift capacity is 10,000 lbs/9,000 lbs. with 2,500 lbs/2,250 lbs. per arm pad.
- Check the trunk or other storage areas for loads that would affect the vehicle balance.
- Prior to lifting vehicle, walk around the lift and check for any objects that might interfere with the operation of lift and safety latches: tools, air hoses, shop equipment.
- When approaching the lift with a vehicle, center the vehicle between the columns so that the tires will clear the swing arms easily. Slowly drive the vehicle up between the posts. Have someone outside the vehicle guide the driver.
- Always lift vehicle using all four arms.
- Always ensure safety stops are engaged before any attempt is made to work on, under, or near the vehicle.
- Never use lift to raise one end or one side of vehicle.
- Raise vehicles about 36" (914mm) and check stability by rocking.
- Prior to lowering vehicle, walk around the lift and check for any objects that might interfere with the operation of lift and safety latches; tools, air hoses, shop equipment. Swing the arms out of the path and slowly drive the vehicle out. Have someone outside the vehicle guide the driver.
-

ALWAYS LOCK THE LIFT BEFORE GOING UNDER THE VEHICLE.

NEVER ALLOW ANYONE TO GO UNDER THE LIFT WHEN RAISING OR LOWERING.

MAINTENANCE SCHEDULE

WARNING: USERS SHOULD ALWAYS INSPECT LIFTING EQUIPMENT AT THE START OF EVERY SHIFT. THESE AND OTHER PERIODIC INSPECTIONS ARE THE RESPONSIBILITY OF THE USER.

Before any maintenance or inspection is performed, minimum safety requirements covering LOCKOUT/TAGOUT of all energy sources for personal safety.

Remember that this means all energy: air, gravity (raised lift), hydraulic, electrical, etc. must be **securely locked out**. LOCKOUT/TAGOUT is an requirement of OSHA/NIOSH to ensure worker safety.

Practice good housekeeping. Keep the area around the lift clean and free of obstacles to provide access and to avoid interference with the function or safe operation of the lift. Keep emergency paths clear.

Establish routine periodic inspections of the entire conveyor to ensure continuous maximum operating condition.

Before working on or inspecting the lift, proceed as follows:

1. Lower the lift fully.
2. LOCKOUT and TAGOUT all stored energy including electrical power and hydraulic pressure.

If parts are being removed, release tension from the synchronizing cables before removing any parts. See Installation Step Five - Connecting the Synchronizing Cables.

DAILY MAINTENANCE

(Performed by the owner/operator)

1. Walk around the lift at the start of each shift. Look for damaged or bent parts on the lift, oil leaks and damaged concrete around the floor anchors or any thing else that may interfere with the safe operation of the lift.
2. Raise the lift about 12 inches check for safe operation of swing arm restraints. Look for vibration or bouncing when lifting. If seen go to trouble shooting chart.
3. Lower lift to ground, and continue use, only if no malfunctions were found.

MONTHLY MAINTENANCE

(Performed by the owner/operator)

1. Raise lift to mid-point of travel and lower onto safety stops.
2. Check both safeties are fully engaged and functioning correctly.
3. Disconnect from electrical power. Ensure the lift control cannot be re-energized according to lockout/tag-out procedures.
4. Check all cable connections, bolts, pins, lift pads and pad extensions to ensure proper fit and tightness. Replace or repair as needed. If excess looseness in arm pivot pins is seen, lift has been overloaded and is unsafe. Stop using the lift.
5. Check for equal tension on synchronizing cables and adjust as needed. (See Installation instructions Step Five – Connecting the Synchronizing Cables points seven and eight.) Also check the cable over the full length for kinks, bends or other permanent deformation or damage. If any is found, stop using the lift.
6. Lubricate inside columns with EP-2 Grease.

- 7.Lubricate cables with a light penetrating oil.
- 8.Lubricate the pulley shafts with oil.
- 9.While raising the lift,check overhead cutoff switch for proper operation.
- 10.Check all anchor bolts for tightness and tighten if needed.

ANNUAL MAINTENANCE

(Performed by the trained lift service personnel only.)

- 1.Follow steps 1 to 5(inclusive)of Monthly Maintenance,detailed above.
- 2.Using a vernier caliper or micrometer,check the diameter of the cable 24"below the carriage and 24"above the carriage.The diameter of the cable should be no less than.367"(9.31mm)or more than .421"(1069mm).
- 3.Check the cable over the full length for kinks,bends or other permanent deformation or damage. Also check the flats on the outer strands of the cable.If the flats are larger in any one area,verify the cable diameter is not outside the dimensions listed above.If any damage to the cable is noted or the measurements are out of spec,stop using the lift and have it repaired before further use.
- 4.Continue with Monthly Maintenance Step 6.
- 5.Check columns for alignment and plumbness.Re-shim as required.
- 6.Check all anchor bolts for tightness.Tighten if needed.

For all other maintenance,if any deficiencies are noted,or any parts need to be replaced,please contact a qualified repair contractor or Best Buy Automotive.

Broken or damaged parts must be replaced only with genuine OEM parts available from Best Buy Automotive.

TROUBLE SHOOTING

Problem	Possible Cause	Possible Solution	Instructions
Motor does not run	<ul style="list-style-type: none"> - Check Fuse or circuit breaker - Check for correct voltage to motor - Inspect all wiring connections - Limit switch is broken or stuck - Push button jammed or broken - Motor overload tripped - Motor winding burned out 	<ul style="list-style-type: none"> - Replace fuse or reset breaker - Supply correct voltage to motor when under load - Repair and insulate all connections - Replace switch or repair actuator - Replace push button - Reset motor overload - Replace motor 	<ul style="list-style-type: none"> - Voltage drop should not exceed 3% when under load - Look for broken wires or loose connector screws - Actuator must move freely, check for bent parts
Motor runs but will not raise unloaded lift	<ul style="list-style-type: none"> - Low oil level - Open lower valve - Pump is sucking air - Motor is running in reverse - Relief valve is stuck open 	<ul style="list-style-type: none"> - Fill with proper oil - Check or Clean Lowering Valve - Suction line in reservoir loose - Reverse leads inside motor - Clean or replace valve 	<ul style="list-style-type: none"> - Lower lift to bottom, oil level should be at the bottom of the filler - Release handle should move freely and lowering button should move in & out easily - Tighten suction line and check suction screen is clean - Check the internal wiring or return pump for replacement - This is a safety device, preset at the factory, disassembly could result in personal injury or death

TROUBLE SHOOTING

Problem	Possible Cause	Possible Solution	Instructions
Lift raises unloaded but not when loaded	<ul style="list-style-type: none"> - Dirt in lowering valve - Relief valve dirty or out of adjustment - Lift overloaded - Low Voltage when running loaded 	<ul style="list-style-type: none"> - Clean or repair lowering valve - Clean or replace valve - Reduce load or re-balance load - Increase voltage when under load 	<ul style="list-style-type: none"> - Release handle should move freely and lowering button should move in & out easily - This is a safety device, preset at the factory, disassembly could result in personal injury or death - An unbalanced load can cause excess friction, when close to capacity lift may overload early - There should be no more than 3% voltage drop from fuse/breaker to the lift when under load
Lift will not stay up or settles slowly	<ul style="list-style-type: none"> - Dirt in check valve - Dirt in lowering valve - External Oil Leak 	<ul style="list-style-type: none"> - Clean check valve at oil outlet from pump - Clean lowering valve - Fix oil leaks 	<ul style="list-style-type: none"> - Check valve prevents oil return through pump - Tighten fittings or replace leaking hose & pipes
Slow lifting or lowering speed or oil leaking from filler cap	<ul style="list-style-type: none"> - Air mixed with oil - Clogged suction screen - Incorrect oil viscosity - Pinched hydraulic hose or line 	<ul style="list-style-type: none"> - Leak in suction line - Clean suction filter or screen - Change oil to a different grade - Inspect all line and hoses for visual damage 	<ul style="list-style-type: none"> - Inside reservoir - Inside reservoir - See the chart following this table - Look for kinks or nicks, hose can balloon the inside lining. This is very difficult to find if all else fails replace all hoses

TROUBLE SHOOTING

Problem	Possible Cause	Possible Solution	Instructions
Lift raising unevenly	<ul style="list-style-type: none"> - Synchronizing cables out of adjustment - Lift installed unevenly on the floor 	<ul style="list-style-type: none"> - Tension cables correctly - Shim low column, max 1/2" off the floor 	<ul style="list-style-type: none"> - See text in this manual - If more than 1/2" shim is needed, the floor will have to be repaired or the lift moved.
Anchors keep loosening	<ul style="list-style-type: none"> - Holes are over sized - Concrete floor thin or not strong enough 	<ul style="list-style-type: none"> - Reset anchors - Break up floor and replace concrete 	<ul style="list-style-type: none"> - Remove each bolt and fill hole with a fast setting epoxy concrete repair re-drill hole with new drill - Test a core to see if floor is 3000psi and check thickness as well
Safety locks not engaging	<ul style="list-style-type: none"> - Lock dog sticking - Lock dog return spring broken - Bent or damaged mounting bracket - Release cable out of adjustment 	<ul style="list-style-type: none"> - Lubricate both lock dogs under the side covers - Replace spring - Repair mounting bracket or pivot pin - Adjust release cable 	<ul style="list-style-type: none"> - Lubricate both sides - Check both sides - Do not heat or weld to column, the heat will weaken the steel - See text in this manual
Lift becomes inoperative with vehicle in raised position	<ul style="list-style-type: none"> - Burst hydraulic line or fitting - Low hydraulic fluid level - Defective hydraulic cylinder - Other 	<ul style="list-style-type: none"> - Clear all personnel and equipment near the lift - Contact a local wrecker service that can provide a rollback truck - Contact BBA for replacement parts 	<ul style="list-style-type: none"> - Remember SAFETY FIRST. - The rollback truck should support the vehicle and prevent it from dropping. - Extreme cases may require a forklift. This can damage vehicle undercarriages.

SPECIFICATIONS

	9k	10k
Maximum lifting weight	90001bs	100001bs
Max Lifting Height	72"-(77.75"with Extensions)	
Total Width (outside base plate)	139.5"	
Drive-Through Clearance	96"	
Floor to Overhead Switch	136.75"/140.75"	
Front Arm Reach (min/max)	25.5"/44.25" Three stage arm	
Rear Arm Reach (min/max)	39.5/57.5"	
Drop-in Pad Height	4" -10"	
Inside Column Width	115.75"	
Motor	3HP	
Voltage	220 Volt/1 phase	
Rise	55 seconds	
Max Load per Arm	2250/25001bs	
Minimum Ceiling Height Req	156.4"/160.3"	
Maximum Column Height	145.4"/149.3"	

POWER UNIT

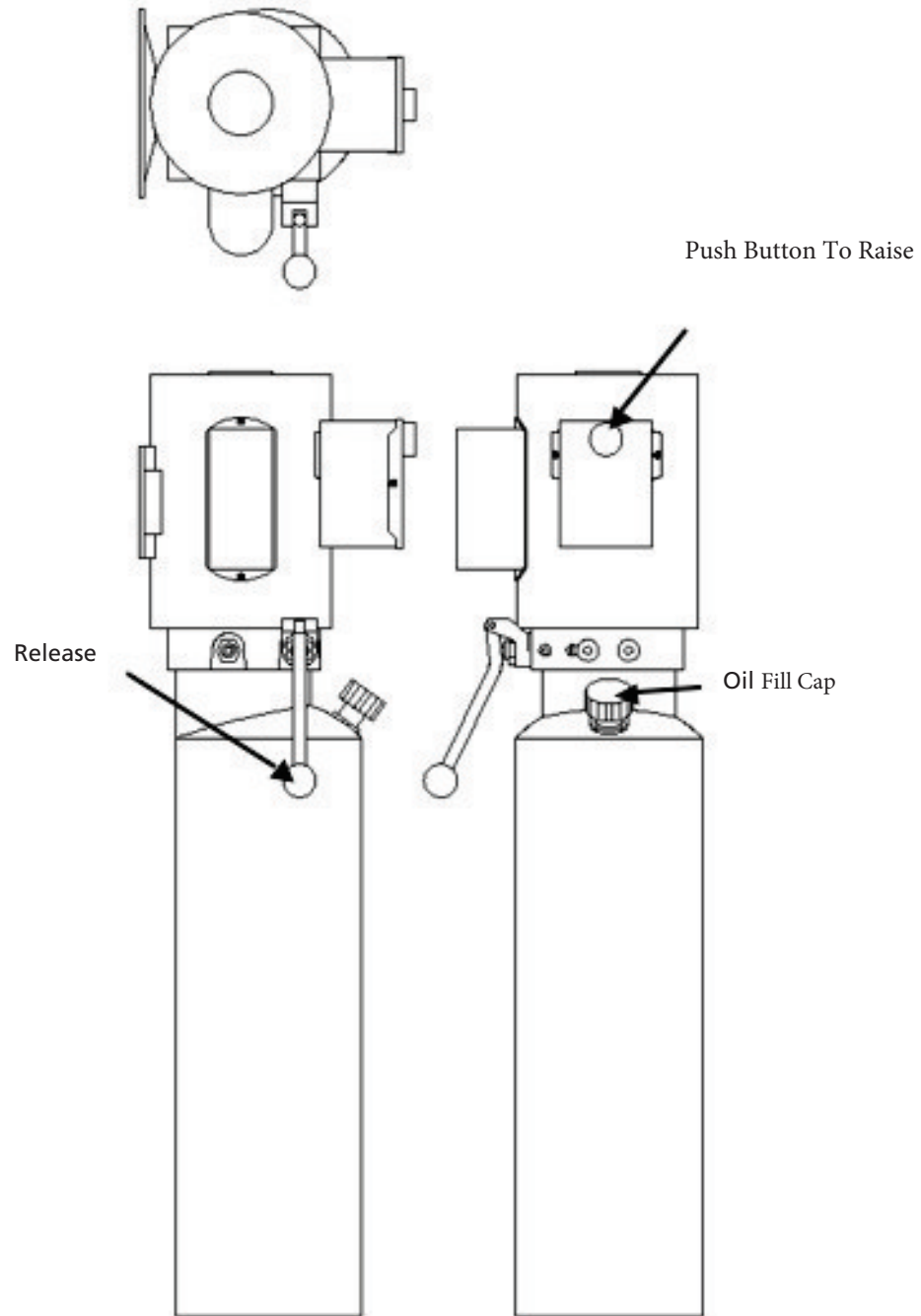

Figure 7

Figure 7 - SAE 10 (ISO Grade AW32) is the only hydraulic fluid recommended for the lift. Use of other fluids may damage the hydraulic equipment or cause the lift to fail.

WARNING: DO NOT USE DEXRON, AUTOMATIC TRANSMISSION FLUID, TRACTOR OIL, OR JACK OIL.

: SYMMETRIC UNIT MEASUREMENTS

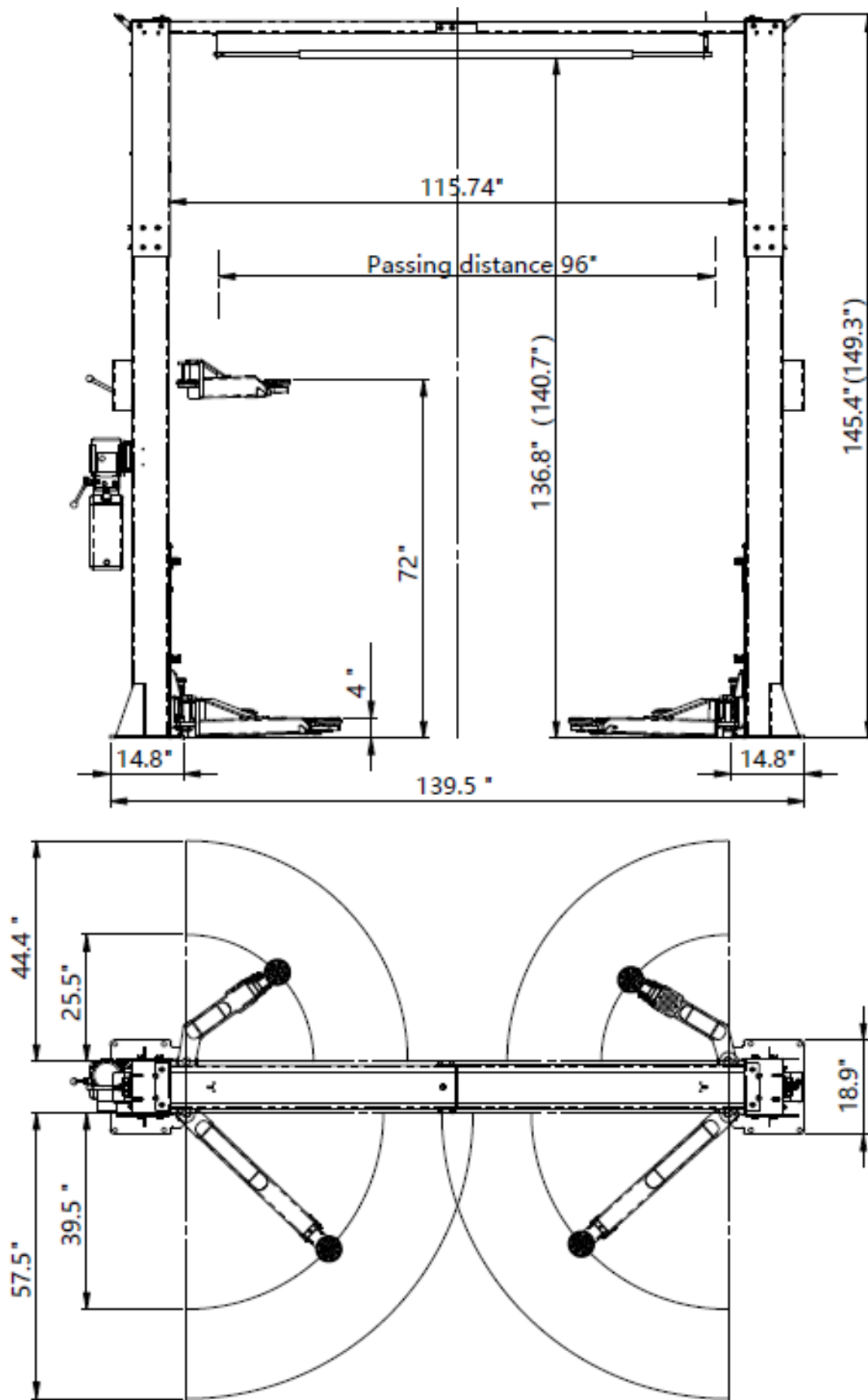
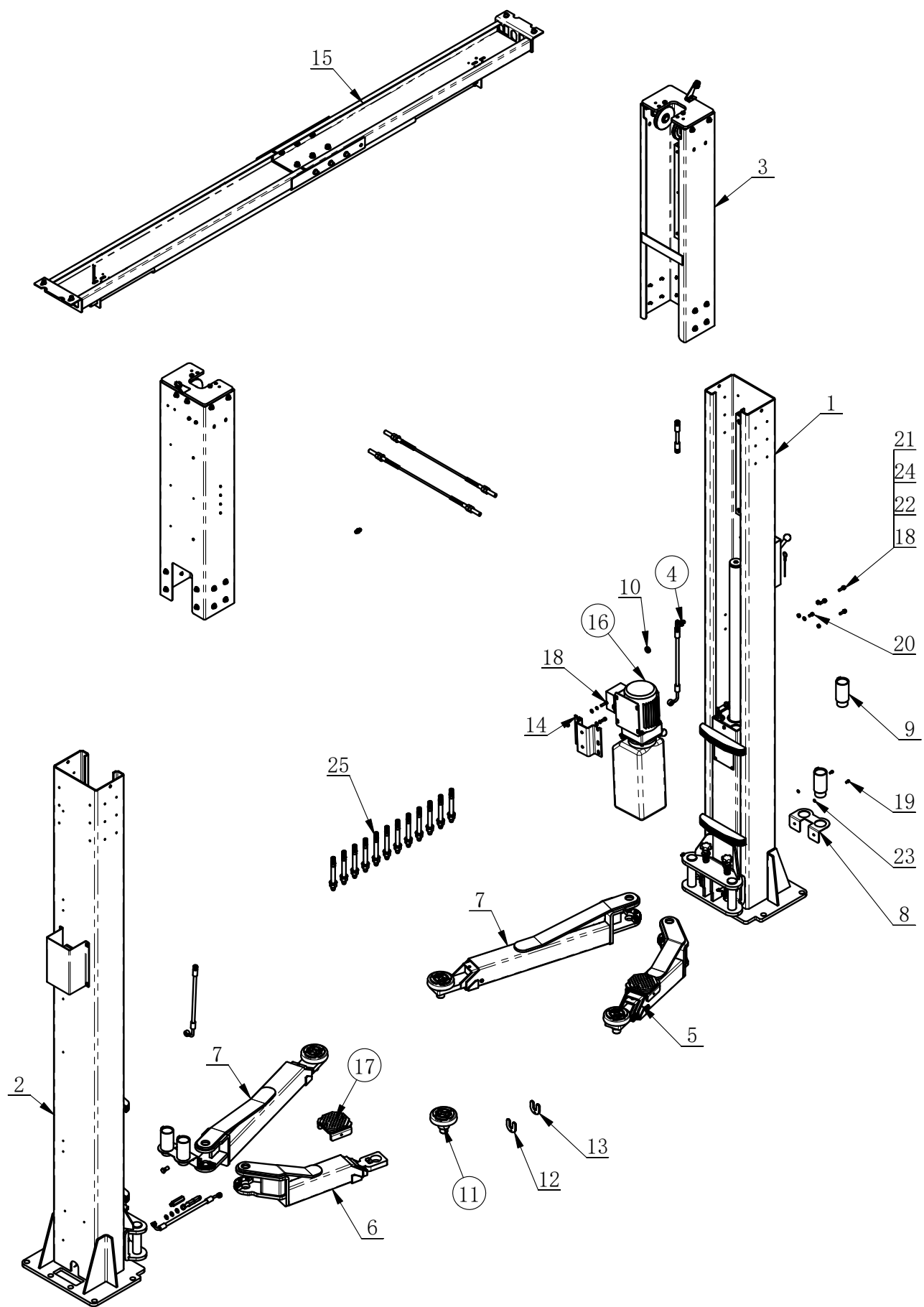

Figure 8

J272-1000000.

Revision A-01



J272-1000000.

Revision A-01

ITEM	PART. No	DESCRIPTION	QT. Y
1	J272-1200000	Sub assembly of auxiliary column	1
2	J272-1300000	Main column subassembly	1
3	J272-1400000	Height increasing section	1
4	J272-1900000	Oil circuit assembly	1
5	J272-5200000	Brackets 630/1110	1
6	J272-5300000	Brackets 630/1110	1
7	J272-5400000	Brackets 865/1376	2
8	J161-1000001	pylons	2
9	J161-1000006	Heightening sleeve II	4
10	J161-1200007	Over coil	1
11	J161-1B00000	LIFTING PADS ASSEMBLY	4
12	J266-1700000	1mm horseshoe pad	5
13	J266-1800000	2mm horseshoe pad	5
14	J271-1000002	Connecting plate of pump station	1
15	J271-1100000	Beam welding assembly	1
16	J271-1800000-220V-1P-60HZ	pumping station	1
17	J271-4400000	Square tray component	2
18	GB5783-M8×30	HEXANGULAR BOLT	4
19	GB70.1-M6×12	INNER HEXA CYLINDRICAL SCREW	4
20	GB70.1-M8×16	INNER HEXA CYLINDRICAL SCREW	2
21	GB6170-M8	HEXANGULAR NUT 1-TYPE	4
22	GB93-8	STANDARD SPRING WASHER	6
23	GB95-6	FLAT WASHER	4
24	GB95-8	FLAT WASHER	7
25	PZLS3-4x6 1-4	Expansion bolt	12

J272-1200000

Revision A-01

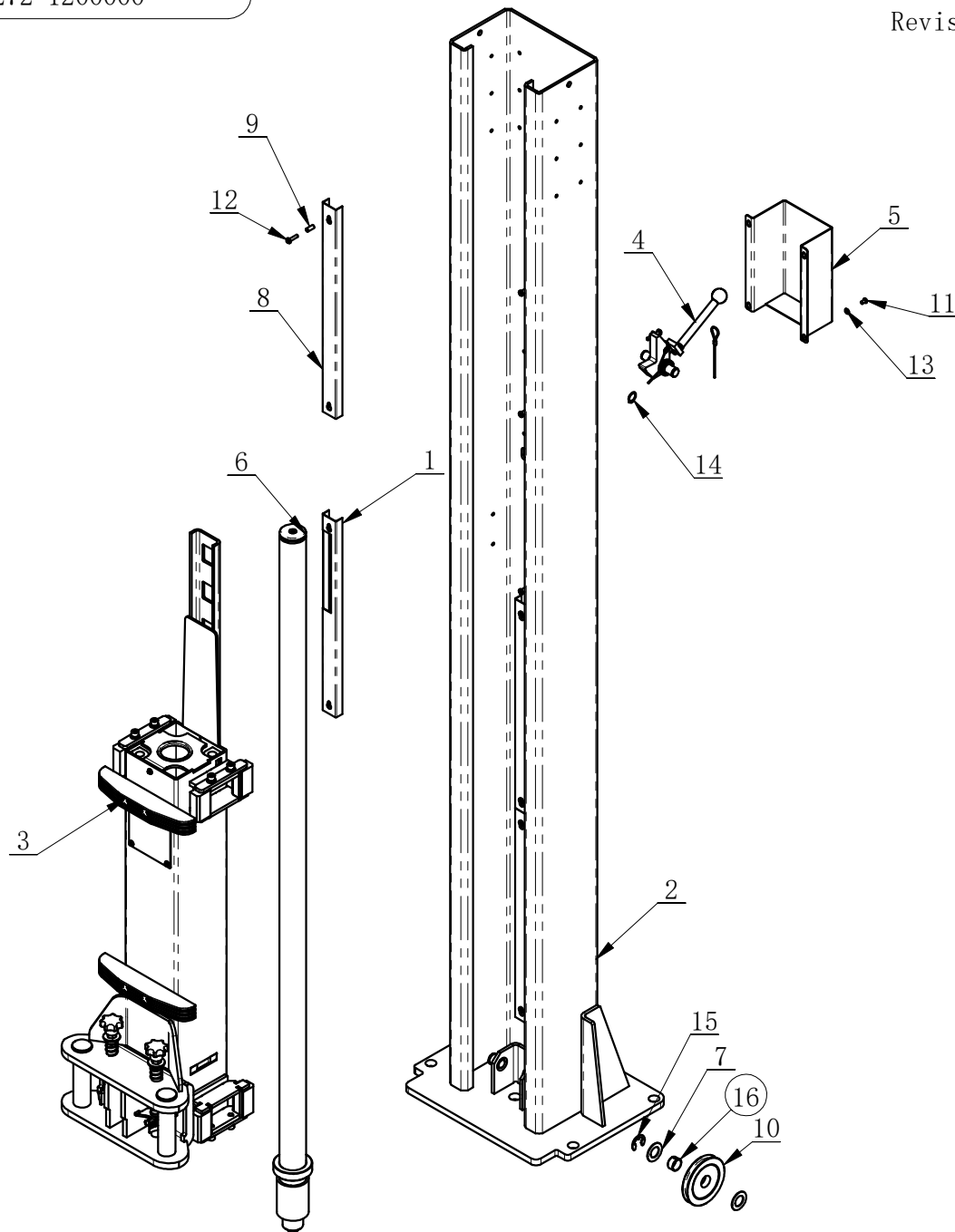

ITEM	PART.No	DESCRIPTION	QT. Y
1	J272-1200002	Oil pipe cover plate	1
2	J272-1210000	Large substructure column (pair)	1
3	J272-1220000	Pulley assembly	1
4	J272-1230000	Lock block component	1
5	J272-1240000	iron cover	1
6	J272-1A00000	hydro-cylinder	1
7	J101-1080004	D25.5 PAD	2
8	J268-1200002	Oil pipe cover plate	3
9	J269H-1200001	Spacer sleeve	8
10	J271-1412001	pulley	1
11	GB70. 2-M6×10	INNER HEXA CYLINDRICAL ROUND HEAD SCREW	4
12	GB818-M6×25-H	CROSS PANHEAD SCREW	8
13	GB97. 1-6	FLAT WASHER A GRADE	4
14	GB894. 1-20	SHAFT ELATIC BIG RETAINING RING A-TYPE	2
15	GB896 - 19	Circlip	1
16	GB12613-25X28X15	SUPPRESSED SHAFT SLEEVE	1

J272-1220000

Revision A-01

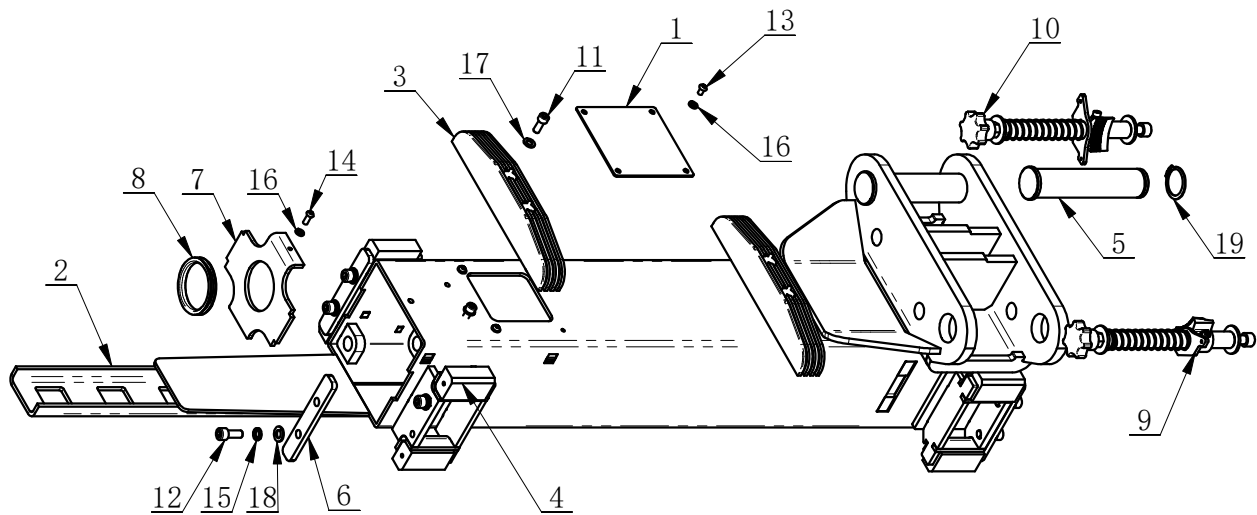

ITEM	PART. No	DESCRIPTION	QT. Y
1	J272-1220001	cover plate	1
2	J272-1221000	Sheave welding assembly	1
3	J101-1000003	PROTECTIVE RUBBER	2
4	J161-1260001	slider	8
5	J161-1260004	Outrigger shaft	2
6	J161-12C0001	baffle	4
7	J268-1220001	Positioning cover	1
8	J268-1220002	rubber ring	1
9	J268-12C3000	SHAFT AS-LOCK	1
10	J268-12C4000	SHAFT AS-LOCK	1
11	GB70. 1-M8×20	INNER HEXA CYLINDRICAL SCREW	4
12	GB70. 1-M10×25	INNER HEXA CYLINDRICAL SCREW	8
13	GB70. 2-M6×10	INNER HEXA CYLINDRICAL ROUND HEAD SCREW	4
14	GB70. 2-M6×16	INNER HEXA CYLINDRICAL ROUND HEAD SCREW	1
15	GB93-10	STANDARD SPRING WASHER	8
16	GB95-6	FLAT WASHER	5
17	GB95-8	FLAT WASHER	4
18	GB95-10	FLAT WASHER	8
19	GB894. 2-38	SHAFT ELATIC RETAINING RING B-TYPE	2

J268-12C3000

Revision A-01

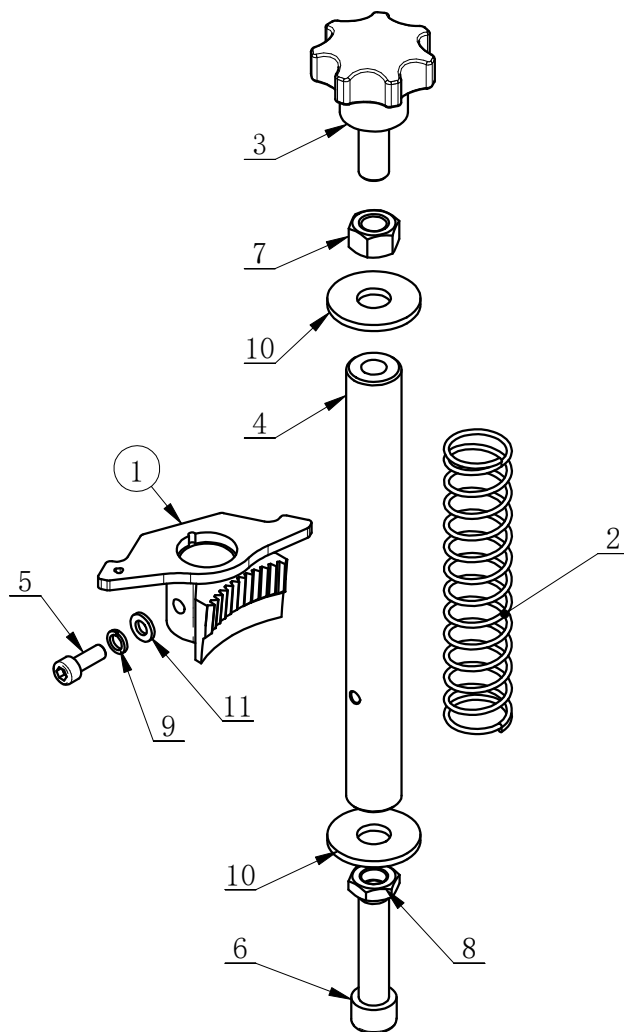

ITEM	PART.No	DESCRIPTION	QT. Y
1	J268-12C3100	Right lock block component	1
2	J161-1262002	Spring	1
3	J161-1262003	HANDLE WHEEL	1
4	J161-12C2002A	Unlock axis	1
5	GB70. 1-M6×16	INNER HEXA CYLINDRICAL SCREW	1
6	GB70. 1-M12×50	INNER HEXA CYLINDRICAL SCREW	1
7	GB6170-M12	HEXANGULAR NUT 1-TYPE	1
8	GB6172. 1-M12	HEXANGULAR THIN NUT	1
9	GB93-6	STANDARD SPRING WASHER	1
10	GB96. 2-12	LARGE WASHER C GRADE	2
11	GB97. 1-6	FLAT WASHER A GRADE	1

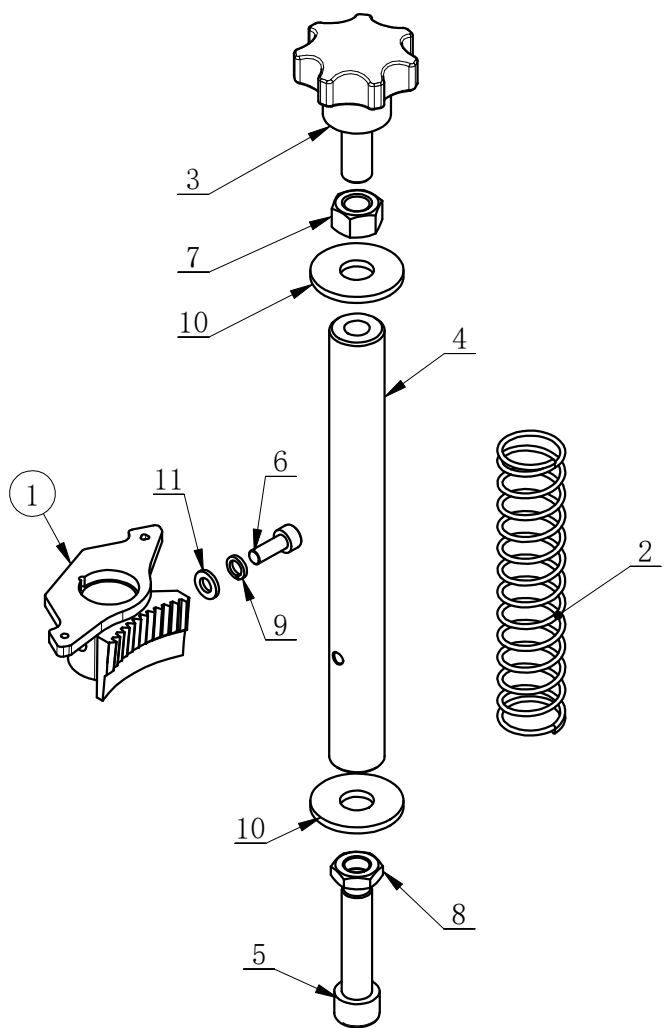

ITEM	PART. No	DESCRIPTION	QT. Y
1	J268-12C4100	Left lock block component	1
2	J161-1262002	Spring	1
3	J161-1262003	HANDLE WHEEL	1
4	J161-12C2002A	Unlock axis	1
5	GB70. 1-M12×50	INNER HEXA CYLINDRICAL SCREW	1
6	GB70. 1-M6×16	INNER HEXA CYLINDRICAL SCREW	1
7	GB6170-M12	HEXANGULAR NUT 1-TYPE	1
8	GB6172. 1-M12	HEXANGULAR THIN NUT	1
9	GB93-6	STANDARD SPRING WASHER	1
10	GB96. 2-12	LARGE WASHER C GRADE	2
11	GB97. 1-6	FLAT WASHER A GRADE	1

J272-1230000

Revision A-01

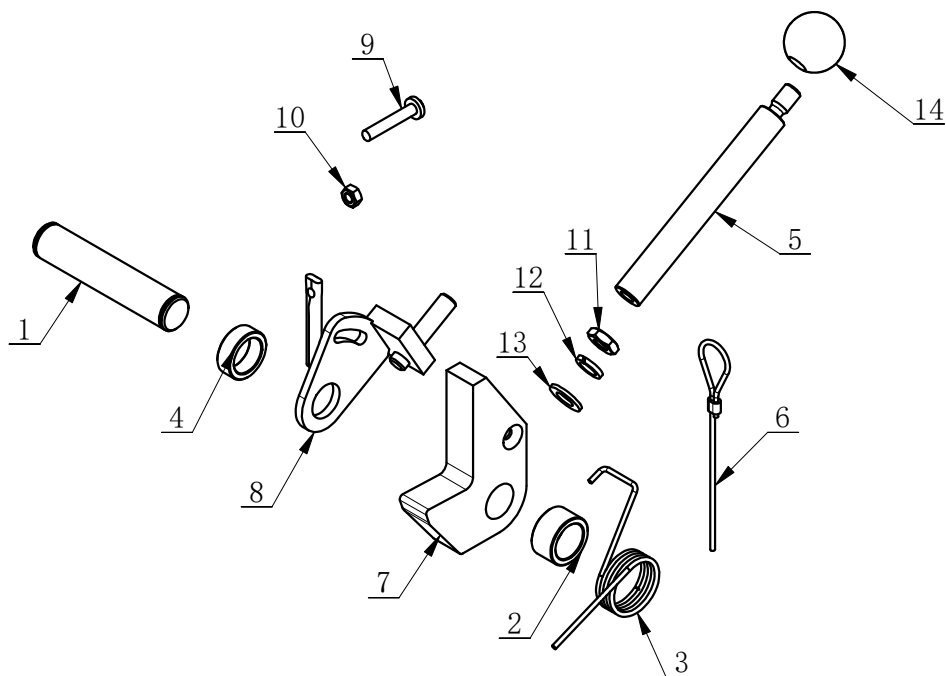

ITEM	PART. No	DESCRIPTION	QT. Y
1	J272-1230001	axle	1
2	J272-1230002	Spacer sleeve	1
3	J272-1230003	SPRING	1
4	J272-1230004	Spacer sleeve	1
5	J272-1230005	control lever	1
6	J272-1230006	wirerope	1
7	J272-1231000	Lock block	1
8	J272-1232000	Rotating plate	1
9	GB818-M6×35-H	CROSS PANHEAD SCREW	1
10	GB6170-M6	HEXANGULAR NUT 1-TYPE	1
11	GB6172.1-M10	HEXANGULAR THIN NUT	1
12	GB93-10	STANDARD SPRING WASHER	1
13	GB95-10	FLAT WASHER	1
14	MH-12-1360011	HAND LEVER	1

J272-1A00000.

Revision A-01

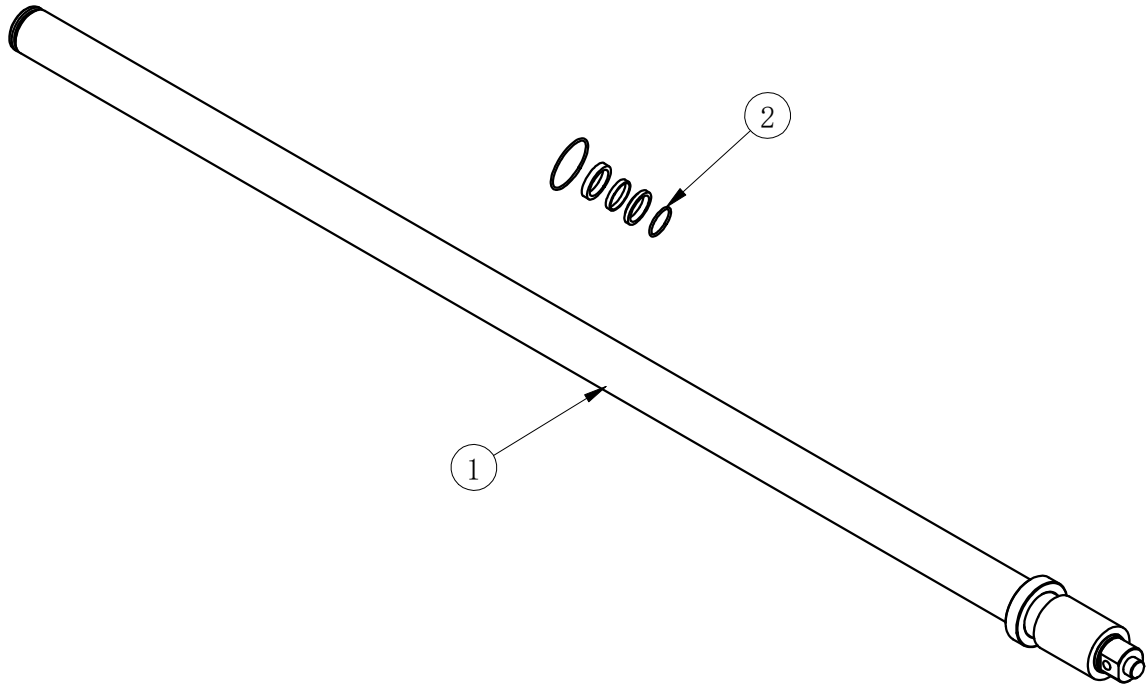

ITEM	PART. No	DESCRIPTION	QT. Y
1	J272-1A00000	hydro-cylinder	1
2	J272-1A00000MFJ	Oil cylinder seal	1

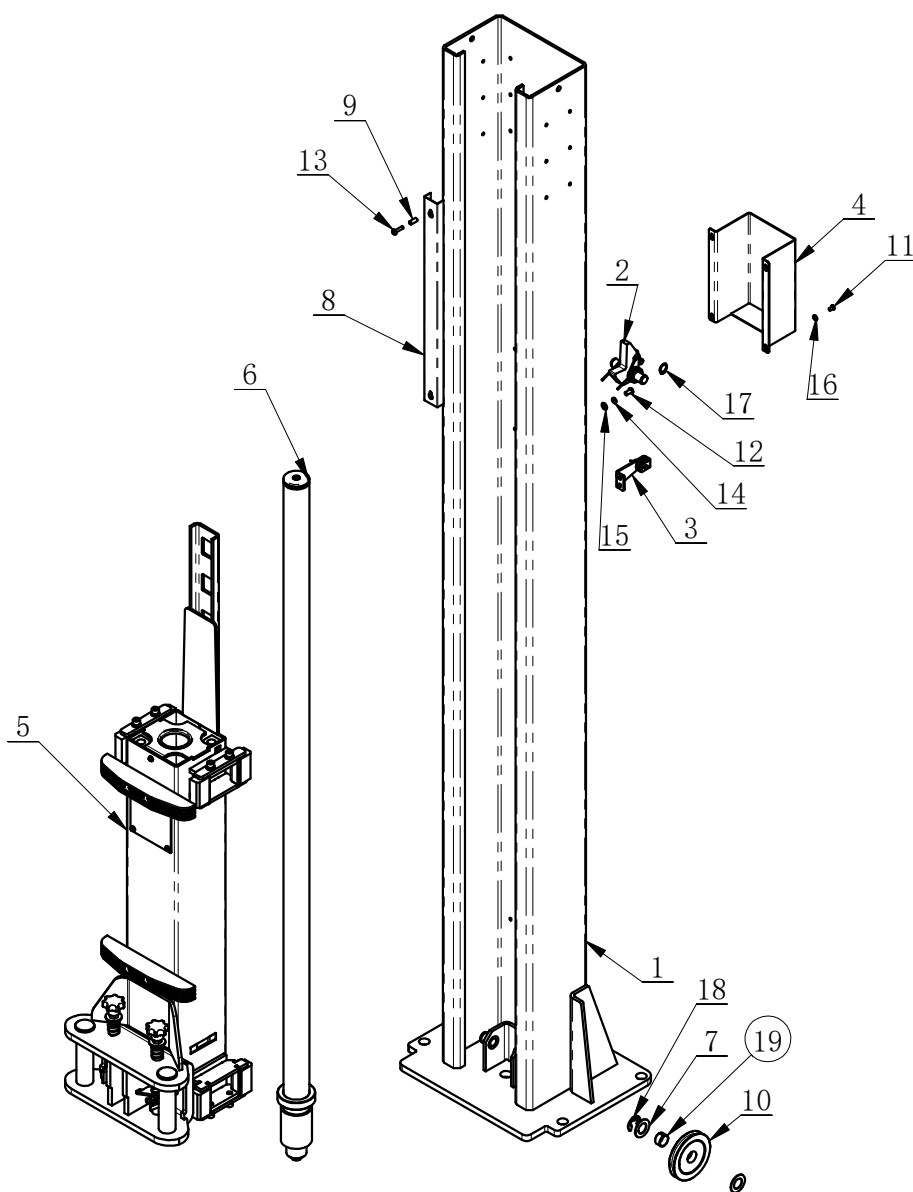

ITEM	PART. No	DESCRIPTION	QT. Y
1	J272-1310000	Large base column (main)	1
2	J272-1320000	Lock block component	1
3	J272-1330000	Roller frame component	1
4	J272-1340000	iron cover	1
5	J272-1220000	Pulley assembly	1
6	J272-1A00000	hydro-cylinder	1
7	J101-1080004	D25.5 PAD	2
8	J268-1200002	Oil pipe cover plate	4
9	J269H-1200001	Spacer sleeve	8
10	J271-1412001	pulley	1
11	GB70. 2-M6×10	INNER HEXA CYLINDRICAL ROUND HEAD SCREW	4
12	GB70. 2-M8×16	INNER HEXA CYLINDRICAL ROUND HEAD SCREW	2
13	GB818-M6×25-H	CROSS PANHEAD SCREW	8
14	GB93-8	STANDARD SPRING WASHER	2
15	GB97. 1-8	FLAT WASHER A GRADE	2
16	GB97. 1-6	FLAT WASHER A GRADE	4
17	GB894. 1-20	SHAFT ELATIC BIG RETAINING RING A-TYPE	2
18	GB896 - 19	Circlip	1
19	GB12613-25X28X15	SUPPRESSED SHAFT SLEEVE	1

J272-1320000

Revision A-01

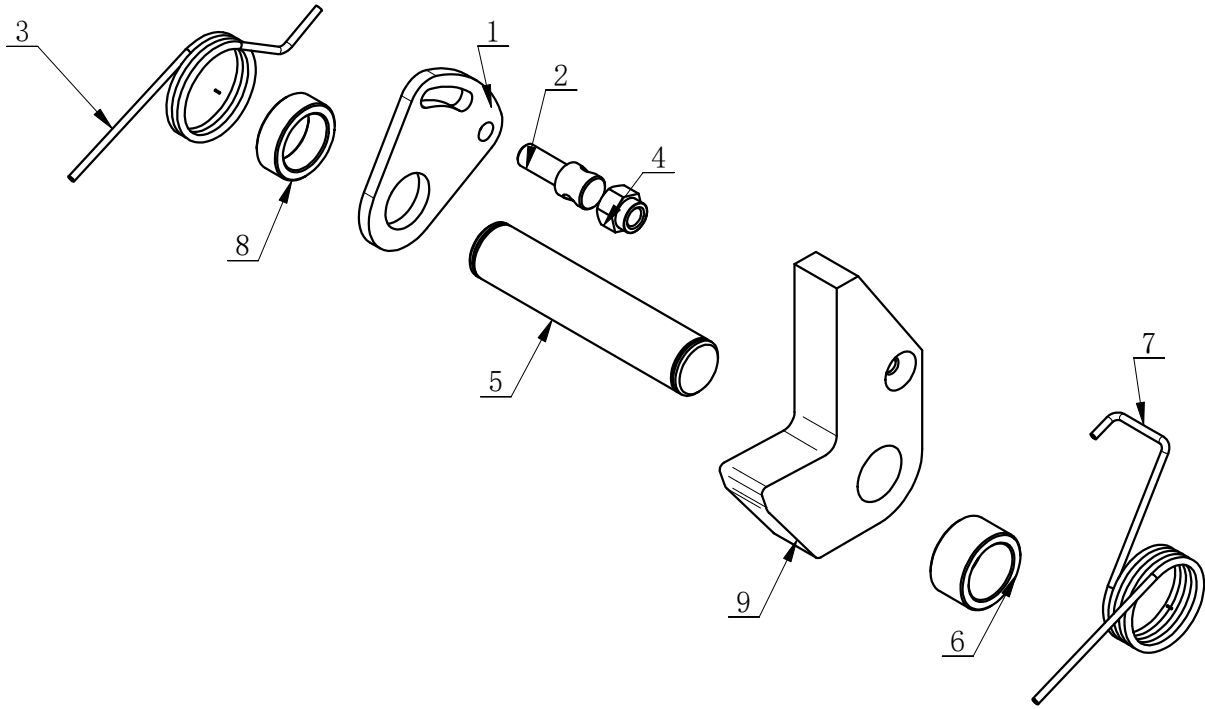

ITEM	PART. No	DESCRIPTION	QT. Y
1	J272-1320001	Rotating plate	1
2	J272-1320002	axle	1
3	J272-1320003	SPRING	1
4	J272-1320004	SPHERIC HEXANGULAR NUT	1
5	J272-1230001	axle	1
6	J272-1230002	Spacer sleeve	1
7	J272-1230003	SPRING	1
8	J272-1230004	Spacer sleeve	1
9	J272-1231000	Lock block	1

J272-1330000

Revision A-01

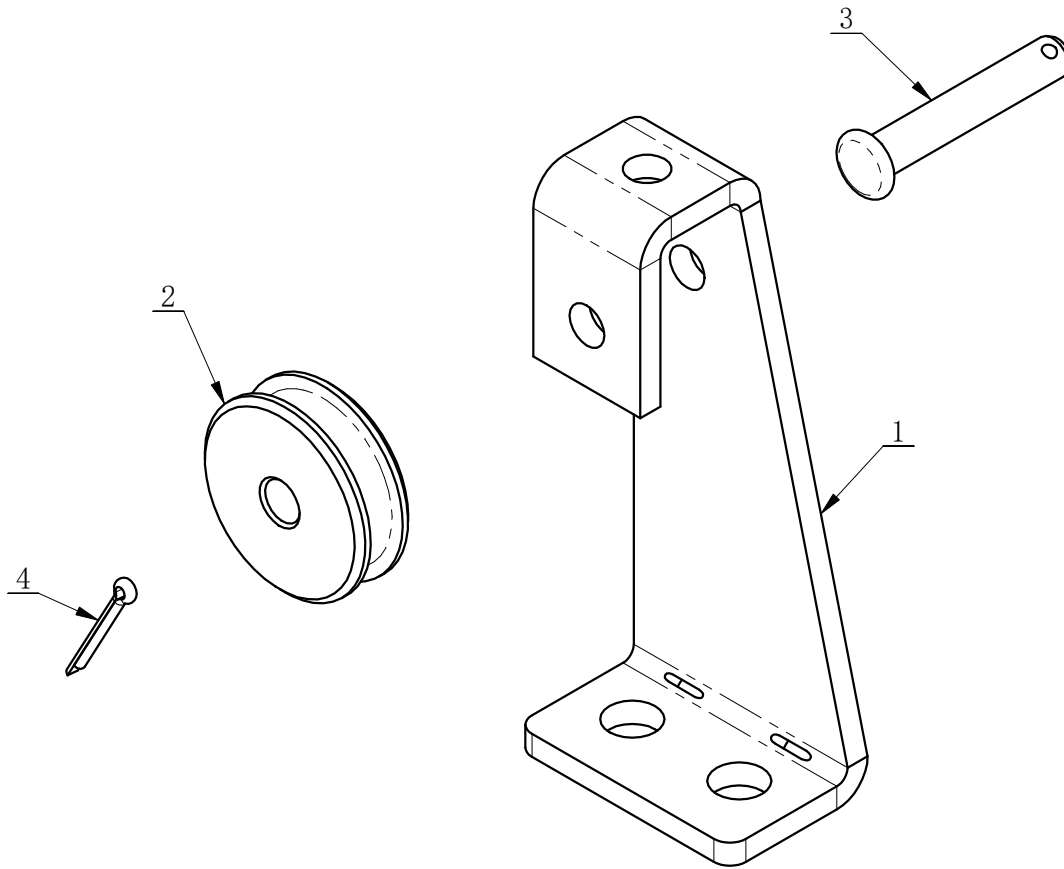

ITEM	PART. No	DESCRIPTION	QT. Y
1	J272-1330002	Roller bracket	1
2	J272-1412002	roller	1
3	GB882-6×35	PIN SHAFT	1
4	GB91-2×16	SLOTTED PIN	1

J272-1400000

Revision A-01

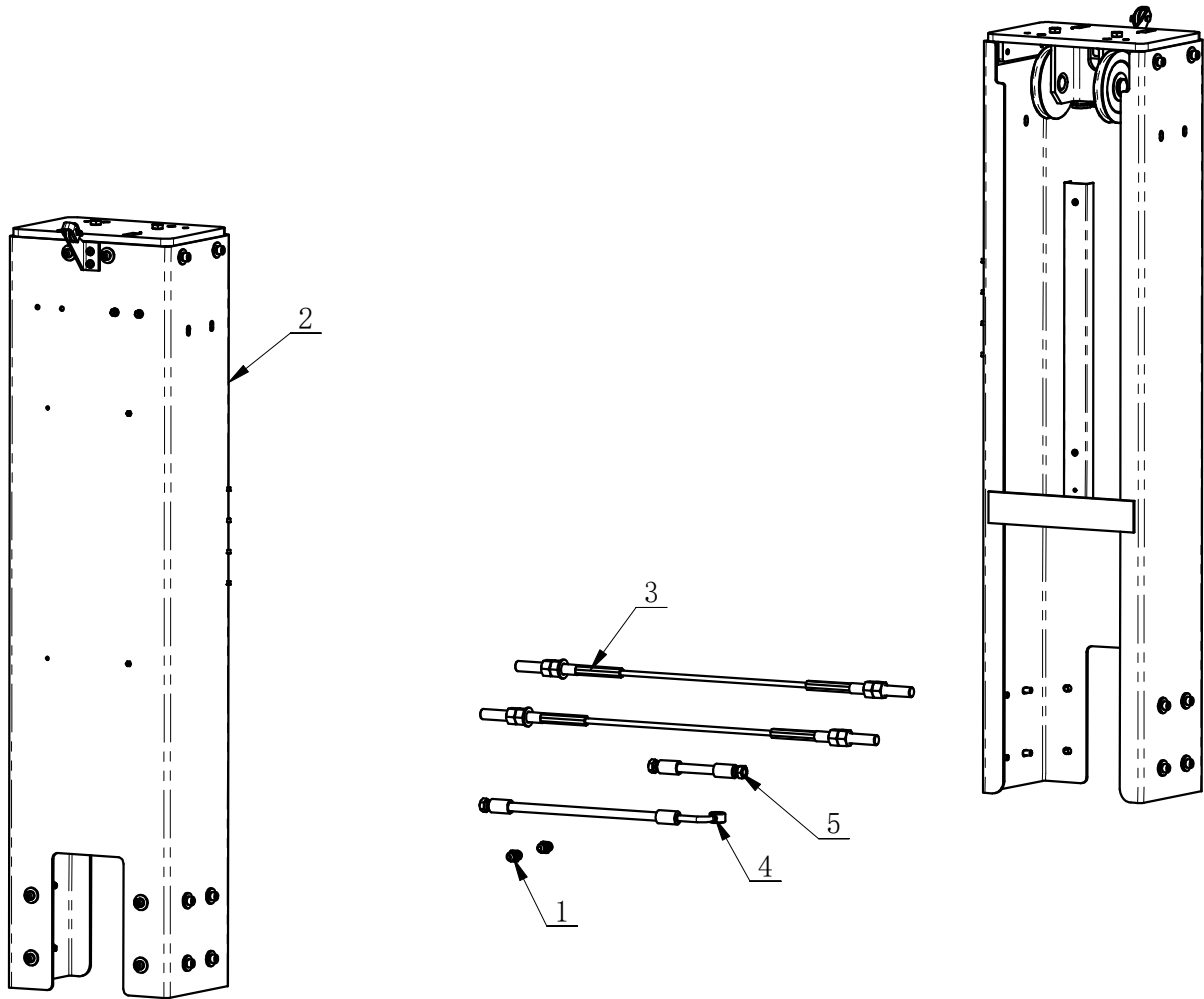

ITEM	PART. No	DESCRIPTION	QT. Y
1	J272-1400001	Metal joint	2
2	J272-1410000	Height increasing section	2
3	J272-1420000	SYNCHRONOUS ROPE	2
4	J272-1430000	SUPPRESSED RUBBER HOSE	1
5	J272-1440000	SUPPRESSED RUBBER HOSE	1

J272-1410000

Revision A-01

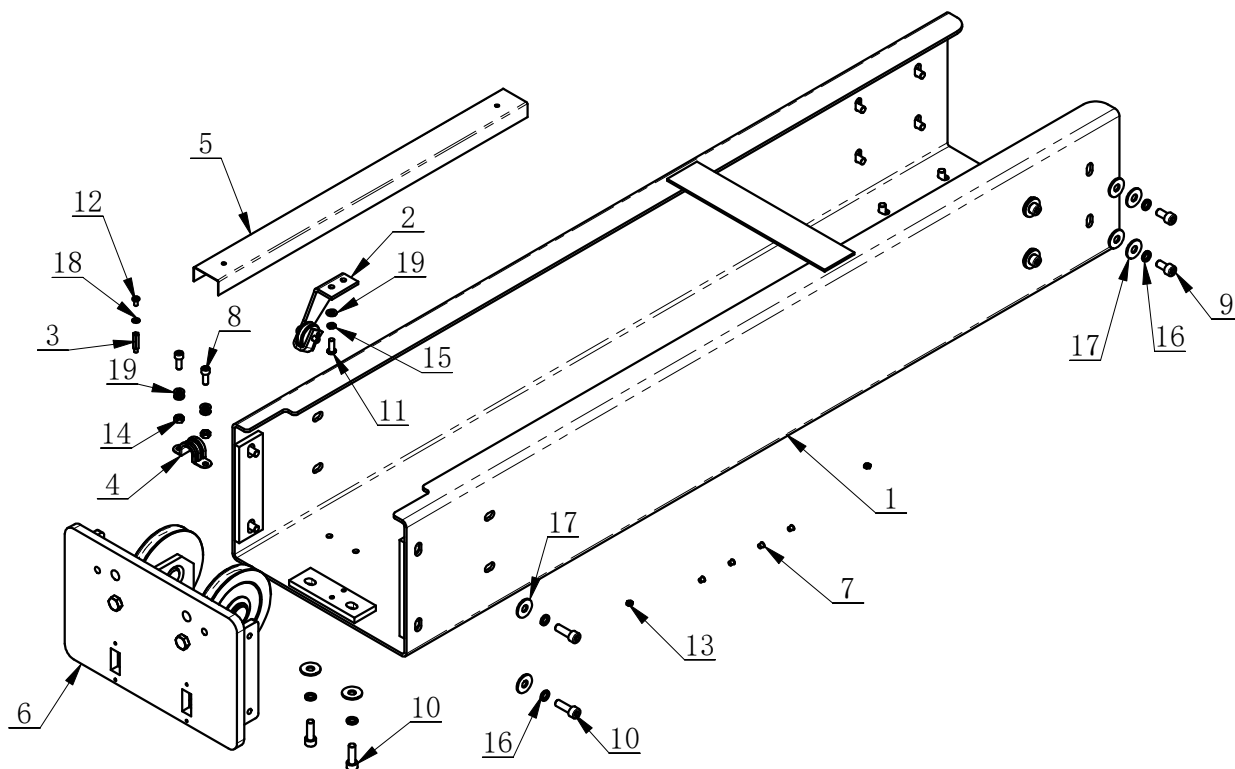

ITEM	PART. No	DESCRIPTION	QT. Y
1	J272-1411000	Height increasing section	1
2	J272-1412000	Roller frame component	1
3	J166-1000004	Cushion pillar	2
4	J262-1200004	Clamp with rubber strip	1
5	J271-1410001	Oil pipe cover plate	1
6	J271-1412000	Gantry upper cover assembly	1
7	4-900355	SNAP RIVETS	4
8	GB70.1-M6×16	INNER HEXA CYLINDRICAL SCREW	2
9	GB70.1-M8×16	INNER HEXA CYLINDRICAL SCREW	12
10	GB70.1-M8×25	INNER HEXA CYLINDRICAL SCREW	6
11	GB70.2-M6×16	INNER HEXA CYLINDRICAL ROUND HEAD SCREW	2
12	GB818-M4×8-H	CROSS PANHEAD SCREW	2
13	GB6170-M4	HEXANGULAR NUT 1-TYPE	2
14	GB6170-M6	HEXANGULAR NUT 1-TYPE	2
15	GB93-6	STANDARD SPRING WASHER	2
16	GB93-8	STANDARD SPRING WASHER	18
17	GB96.2-8	LARGE WASHER C GRADE	26
18	GB97.1-4	FLAT WASHER A GRADE	2
19	GB97.1-6	FLAT WASHER A GRADE	6

J272-1412000

Revision A-01

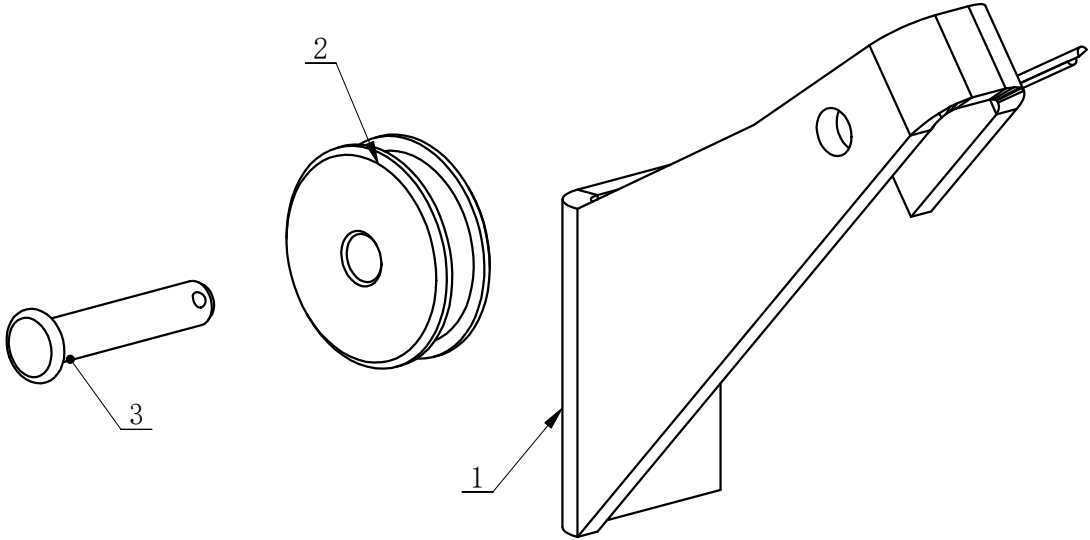

ITEM	PART. No	DESCRIPTION	QT. Y
1	J272-1412001	bracket	1
2	J272-1412002	roller	1
3	GB882-6×30	PIN SHAFT	1
4	GB91-2×16	SLOTTED PIN	1

J272C-1412000.

Revision A-01

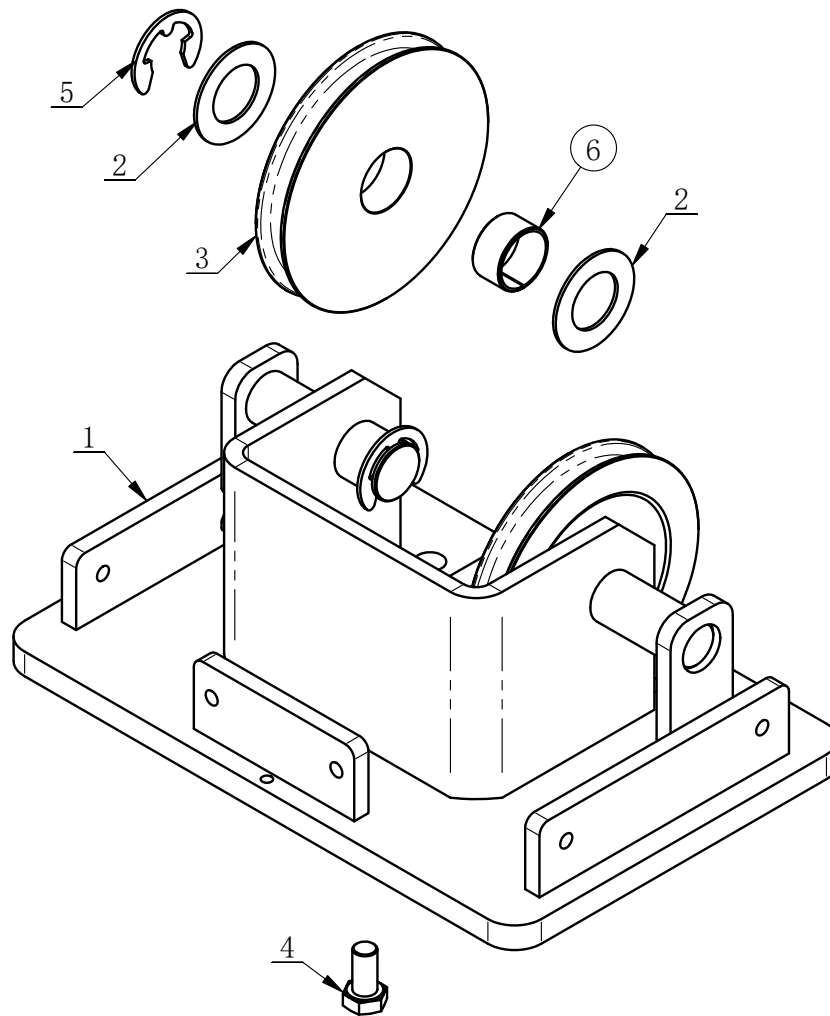

ITEM	PART. No	DESCRIPTION	QT. Y
1	J272C-1231000	Single side gantry top cover	1
2	J101-1080004	D25.5 PAD	4
3	J271-1412001	pulley	2
4	GB5783-M10×20	HEXANGULAR BOLT	2
5	GB896 - 19	Circlip	2
6	GB12613-25X28X15	SUPPERSSED SHAFT SLEEVE	2

J272-1900000

Revision A-01

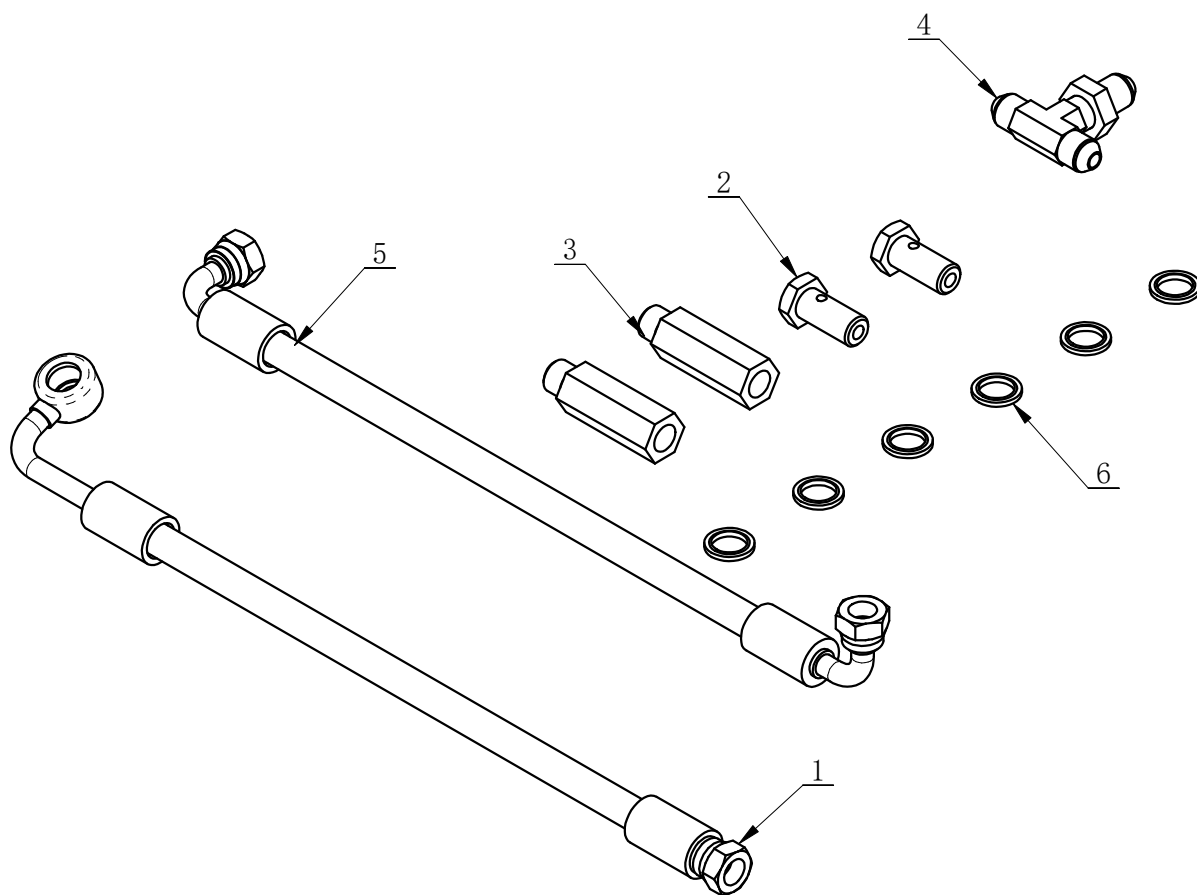

ITEM	PART. No	DESCRIPTION	QT. Y
1	J272-1920000	SUPPRESSED RUBBER HOSE	1
2	J101-1140005	BRITISH HINGE BOLTS	2
3	J268-1900001	Oil pipe joint	2
4	J271-1900002	Oil pipe joint	1
5	J271-1910000	SUPPRESSED RUBBER HOSE	1
6	JB982-13	gasket	6

J272-5200000

Revision A-01

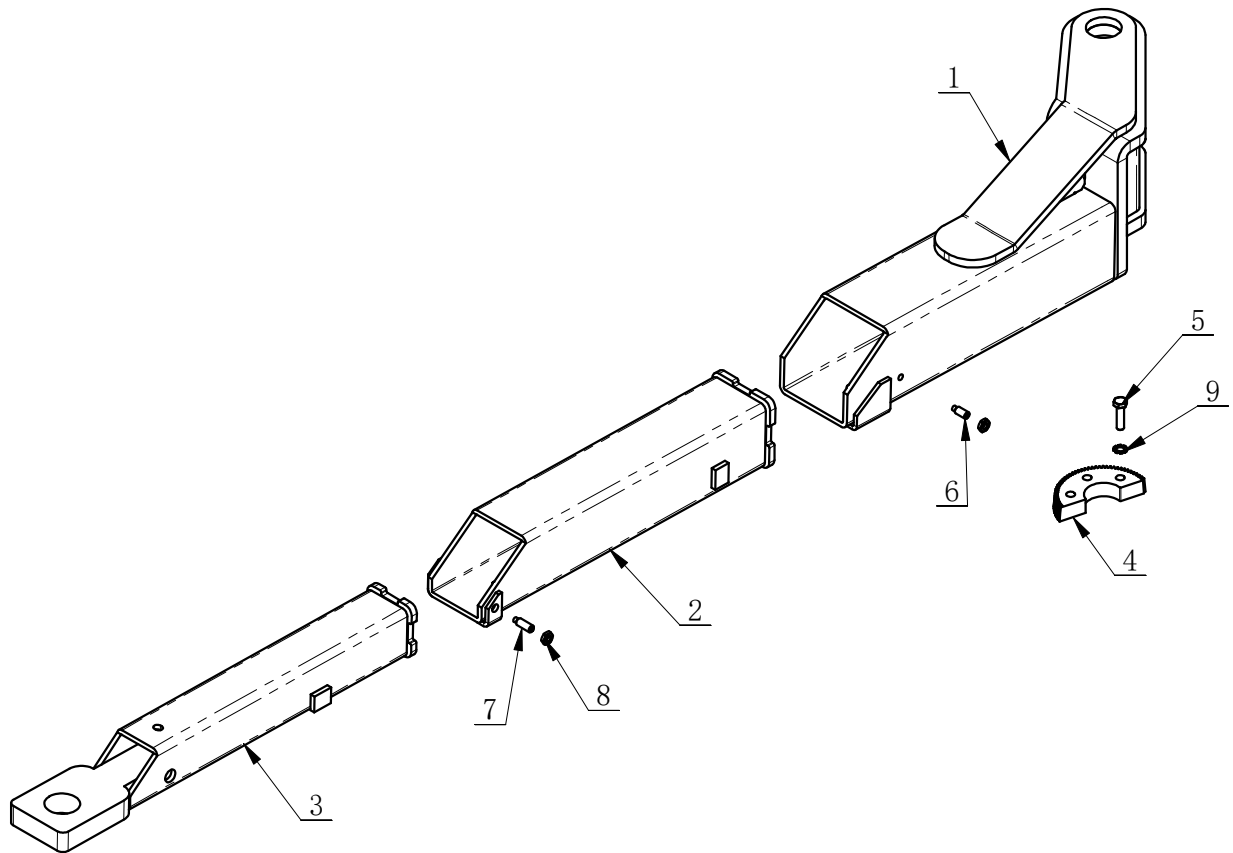

ITEM	PART.No	DESCRIPTION	QT. Y
1	J272-5210000	Foundation arm (left)	1
2	J272-5220000	Pallet arm	1
3	J272-5230000	Pallet arm	1
4	J101-1050001	THE SECTOR GEAR	1
5	GB5783-M8×30-12.9	HEXANGULAR BOLT	3
6	GB79-M8×20	INNER HEXA CYLINDRICAL TERMINUS SET SCREW	1
7	GB79-M8×25	INNER HEXA CYLINDRICAL TERMINUS SET SCREW	1
8	GB6172.1-M8	HEXANGULAR THIN NUT	2
9	GB862.1-8	OUTER TOOTH LOCK WAHSER	3

J272-5300000

Revision A-01

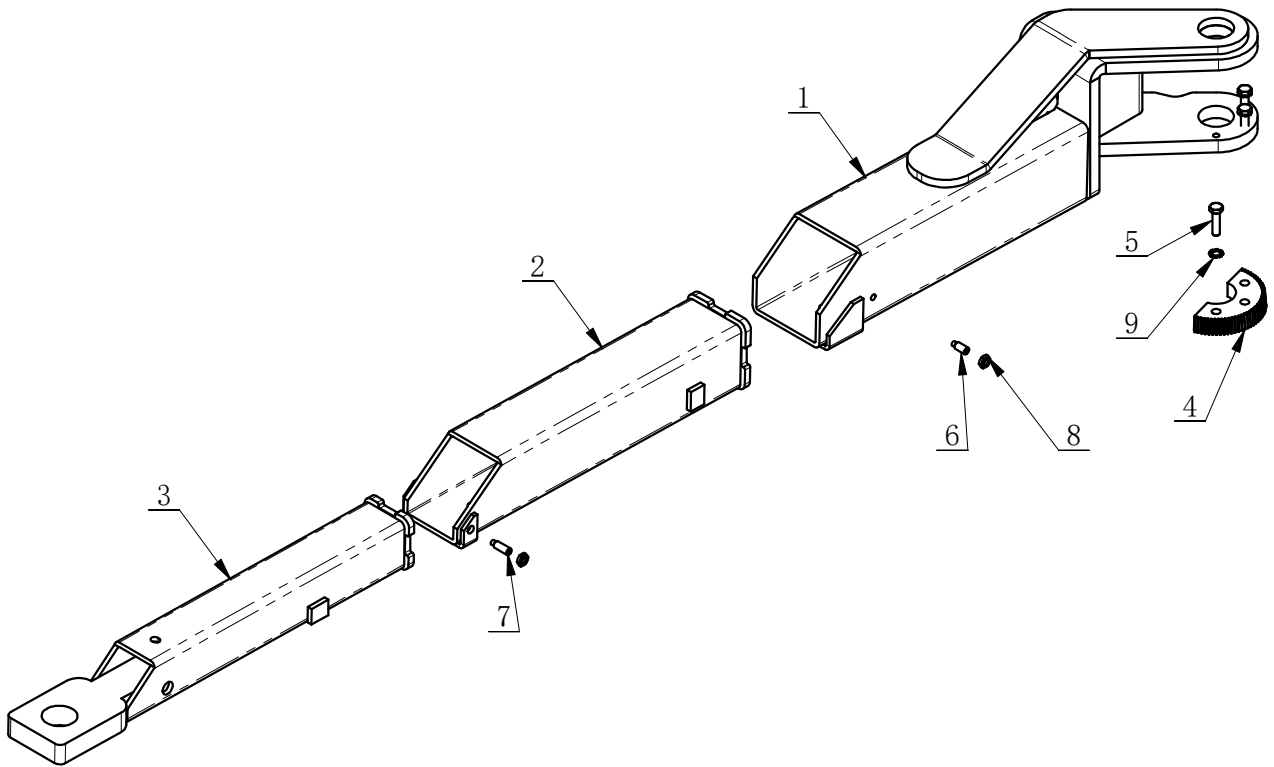

ITEM	PART. No	DESCRIPTION	QT. Y
1	J272-5310000	Foundation arm (left)	1
2	J272-5220000	Pallet arm	1
3	J272-5230000	Pallet arm	1
4	J101-1050001	THE SECTOR GEAR	1
5	GB5783-M8×30-12.9	HEXANGULAR BOLT	3
6	GB79-M8×20	INNER HEXA CYLINDRICAL TERMINUS SET SCREW	1
7	GB79-M8×25	INNER HEXA CYLINDRICAL TERMINUS SET SCREW	1
8	GB6172. 1-M8	HEXANGULAR THIN NUT	2
9	GB862. 1-8	OUTER TOOTH LOCK WAHSER	3

J272-5400000

Revision A-01

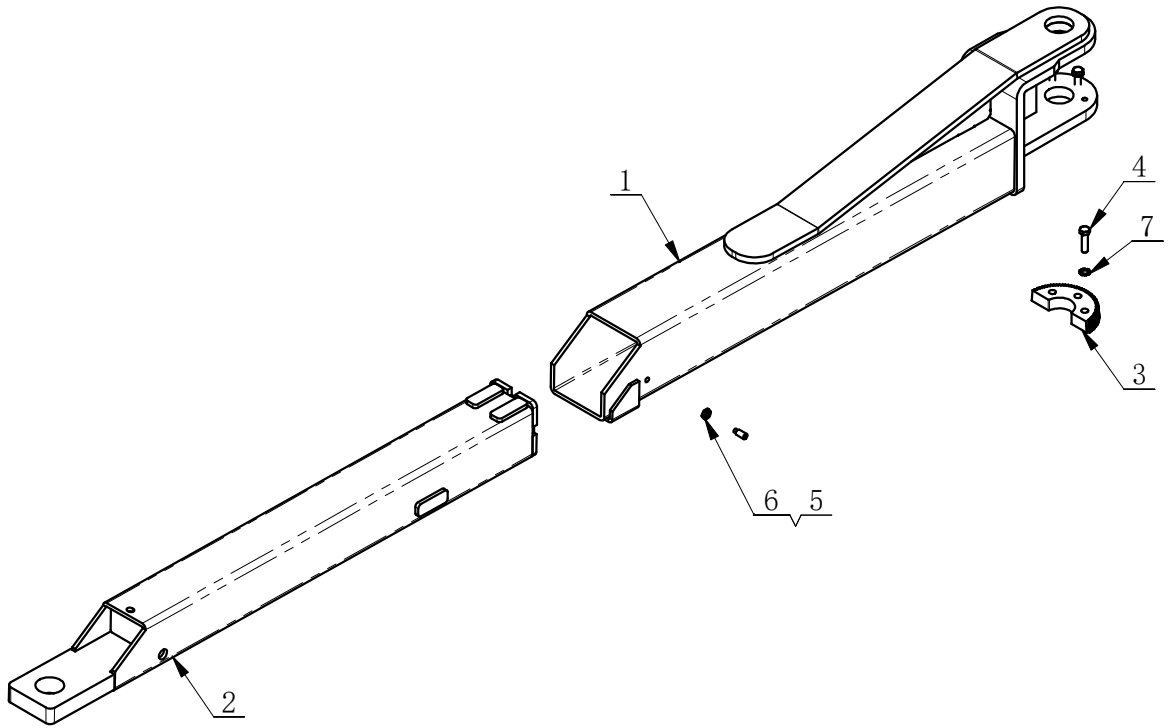

ITEM	PART.No	DESCRIPTION	QT. Y
1	J272-5410000	Arm tube I welding assembly (left)	1
2	J272-5420000	Sliding arm I welding assembly	1
3	J101-1050001	THE SECTOR GEAR	1
4	GB5783-M8×30-12.9	HEXANGULAR BOLT	3
5	GB79-M8×20	INNER HEXA CYLINDRICAL TERMINUS SET SCREW	1
6	GB6172.1-M8	HEXANGULAR THIN NUT	1
7	GB862.1-8	OUTER TOOTH LOCK WAHSER	3

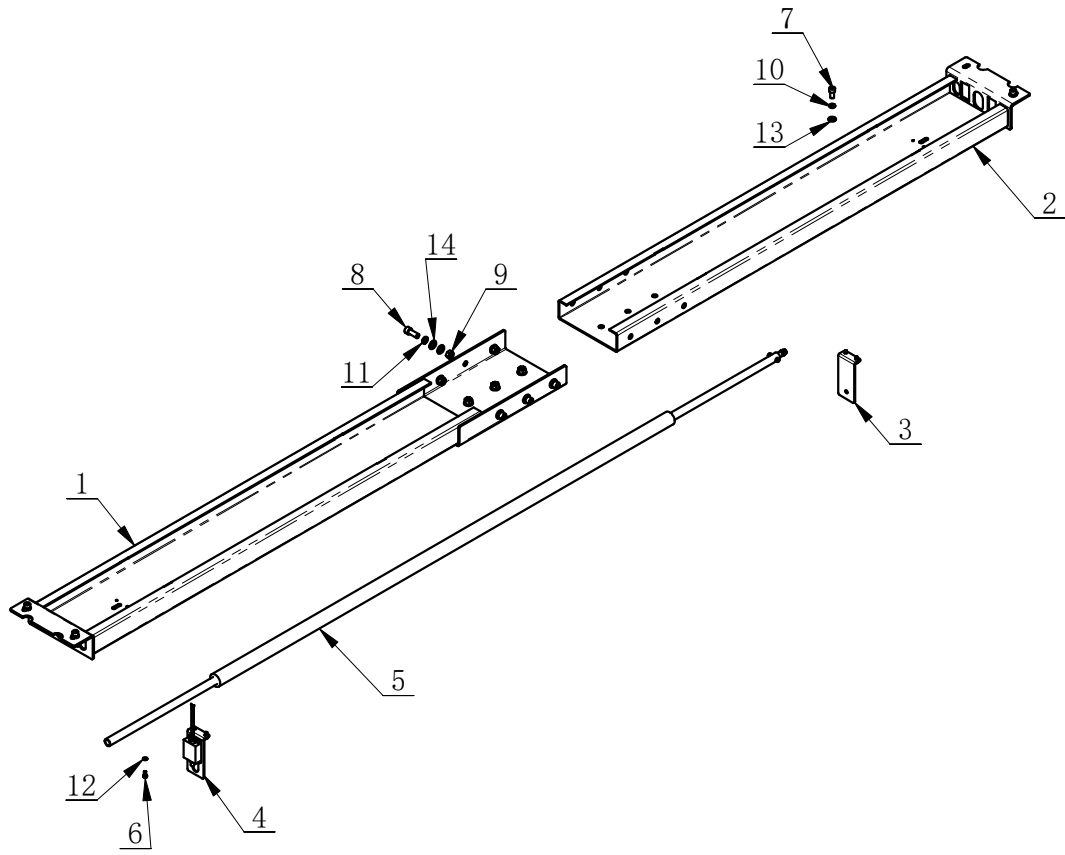

ITEM	PART. No	DESCRIPTION	QT. Y
1	J271-1110000	Beam welding assembly	1
2	J271-1120000	Beam welding assembly	1
3	J261-1000001	Limit frame 2	1
4	J261-1300000	Limit switch assembly	1
5	J261-1400000	Touch bar assembly	1
6	GB70. 1-M6×12	INNER HEXA CYLINDRICAL SCREW	4
7	GB70. 1-M10×20	INNER HEXA CYLINDRICAL SCREW	4
8	GB70. 1-M12×30	INNER HEXA CYLINDRICAL SCREW	9
9	GB6170-M12	HEXANGULAR NUT 1-TYPE	9
10	GB93-10	STANDARD SPRING WASHER	4
11	GB93-12	STANDARD SPRING WASHER	9
12	GB95-6	FLAT WASHER	4
13	GB95-10	FLAT WASHER	4
14	GB95-12	FLAT WASHER	18

J261-1300000

Revision A-01

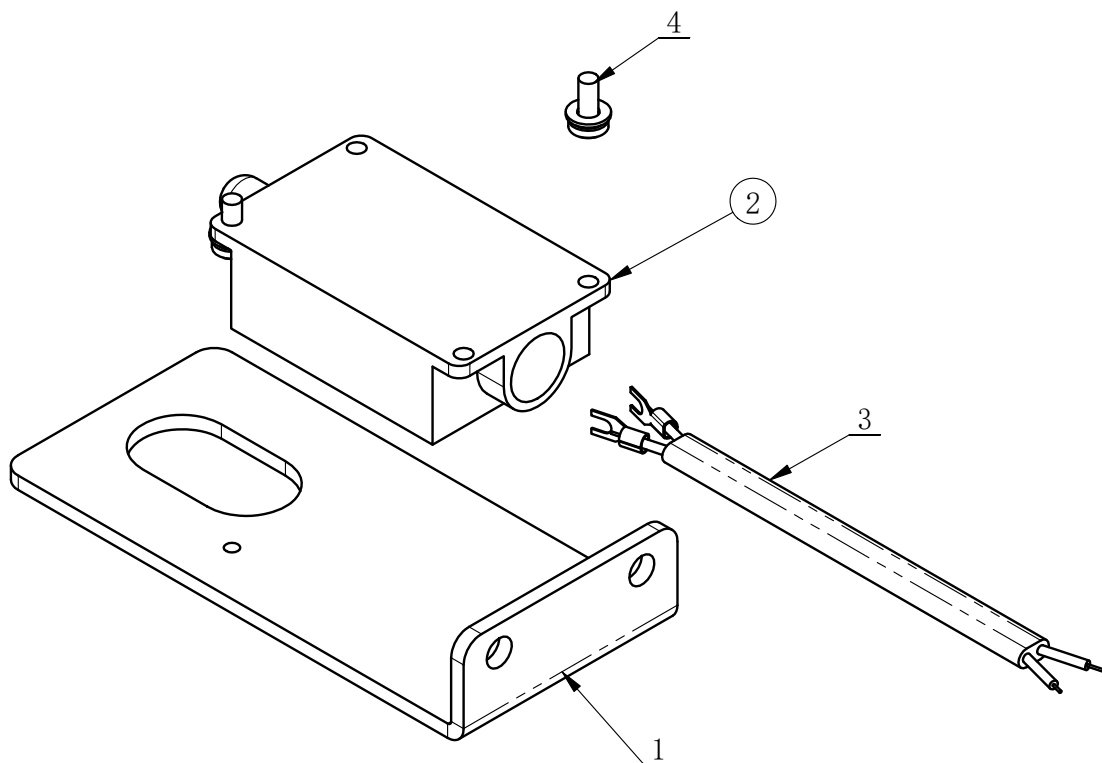

ITEM	PART. No	DESCRIPTION	QT. Y
1	J261-1300001	Limit frame 1	1
2	J261-1300002	Gantry travel switch	1
3	J261-1300003	Upper limit switch wiring	1
4	GB9074. 4-M4x10	Screw M4x10-H	2

J261-1400000

Revision A-01

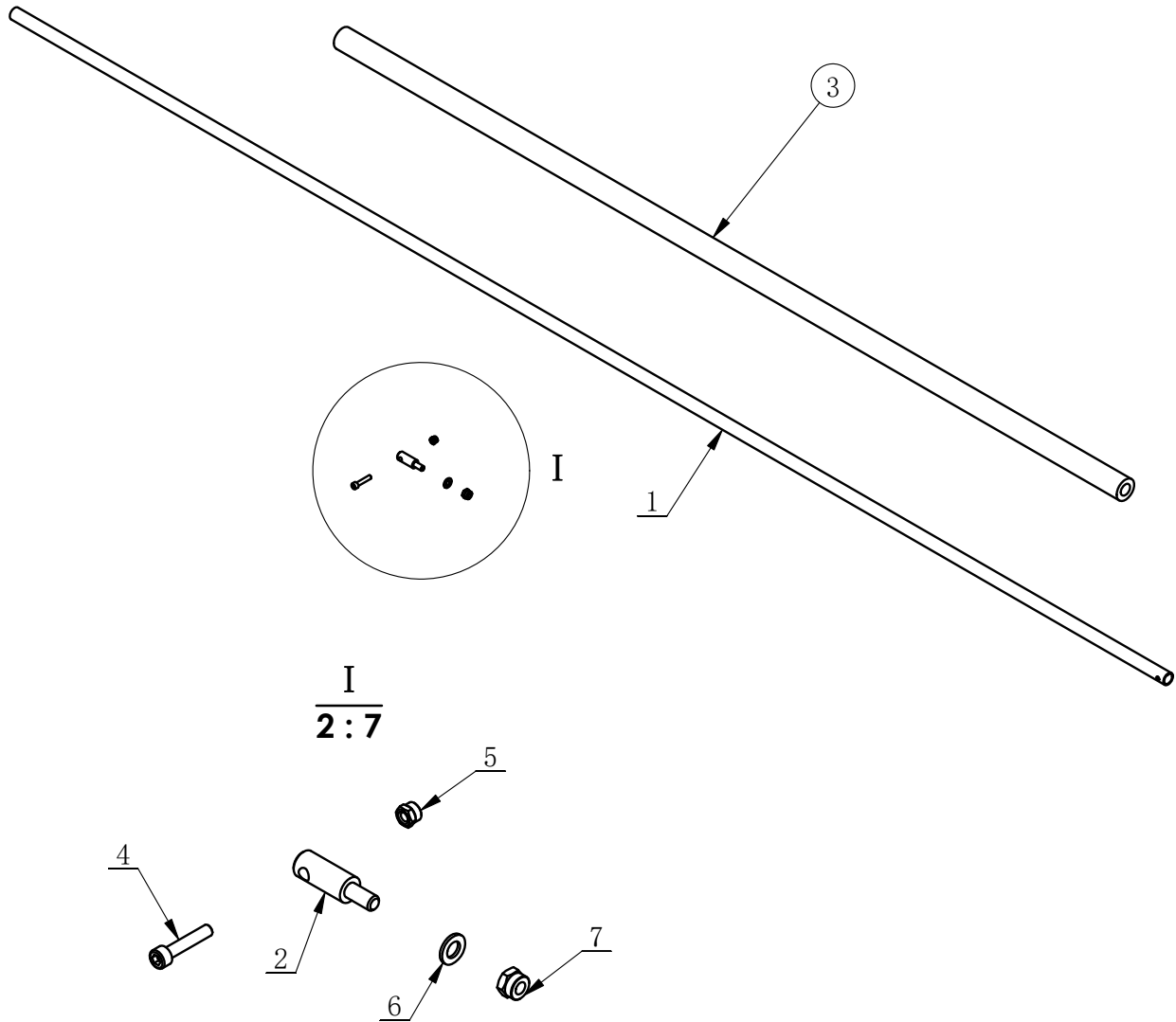

ITEM	PART. No	DESCRIPTION	QT. Y
1	J233-1450001	TOUCH ROD	1
2	J261-1400002	Shaft stopper	1
3	J201-1450003	HEAT PRESERVATION COTTON TUBE	1
4	GB70. 1-M6×30	INNER HEXA CYLINDRICAL SCREW	1
5	GB889. 1-M6	LOCK NUT	1
6	GB95-8	FLAT WASHER	1
7	GB889. 1-M8	1-TYPE PREVAILING TORQUE TYPE HEXAGON LOCK NUT	1

J271-4400000

Revision A-01

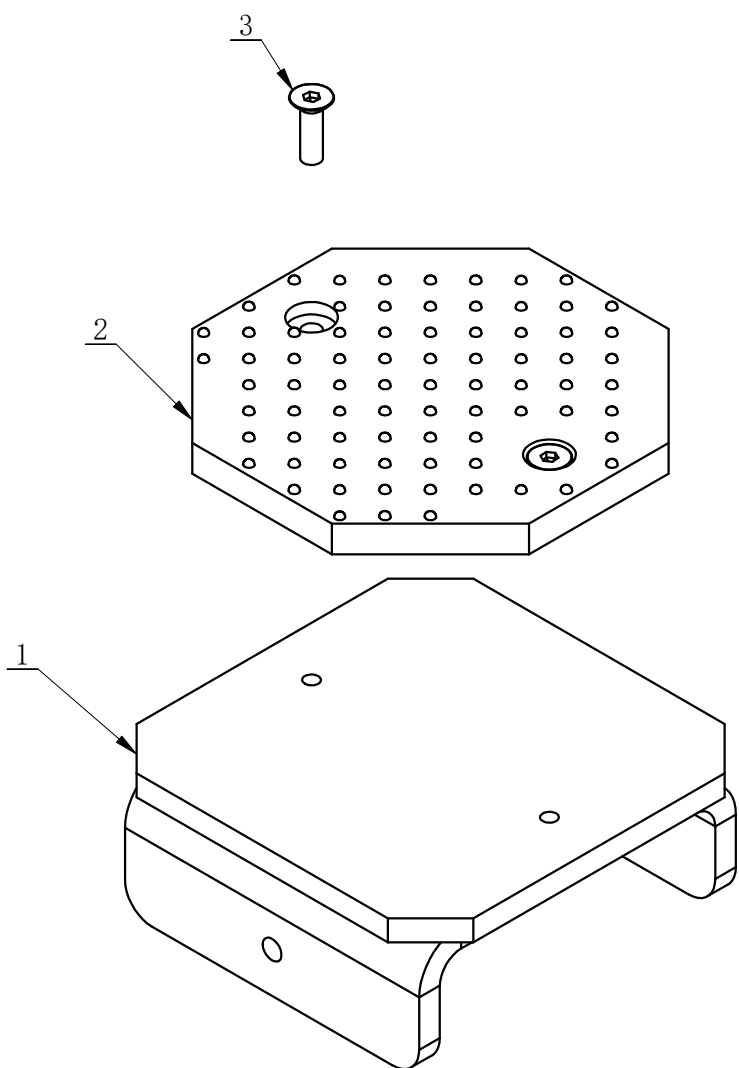

ITEM	PART. No	DESCRIPTION	QT. Y
1	J271-4410000	Bracket	1
2	J271-4400001	Rubber pad	1
3	GB2673-M6×20	HEXA COUNTERSUNK SCREW	2

WIRING THE OVERHEAD SHUT OFF BAR LIMIT SWITCH

FIRST YOU SHOULD CONNECT THE LIFT TO A 220 VOLT/1 PHASE POWER SUPPLY FOLLOWING STEPS 1-4.

- STEP 1.** Remove the “faceplate” or “cover” (the part with the push button) from the power unit.
- STEP 2.** Identify the **#1 HOT WIRE** of the incoming 220v/1ph power supply and connect it directly to the **L2** connection inside of the power unit electrical box.
- STEP 3.** Identify the **#2 HOT WIRE** of the incoming 220v/1ph power supply and connect it directly to the **L3** connection inside of the power unit electrical box.
- STEP 4.** Connect the **GROUND WIRE** of the incoming 220v/1ph power supply to the ground screw inside of the power unit electrical box.

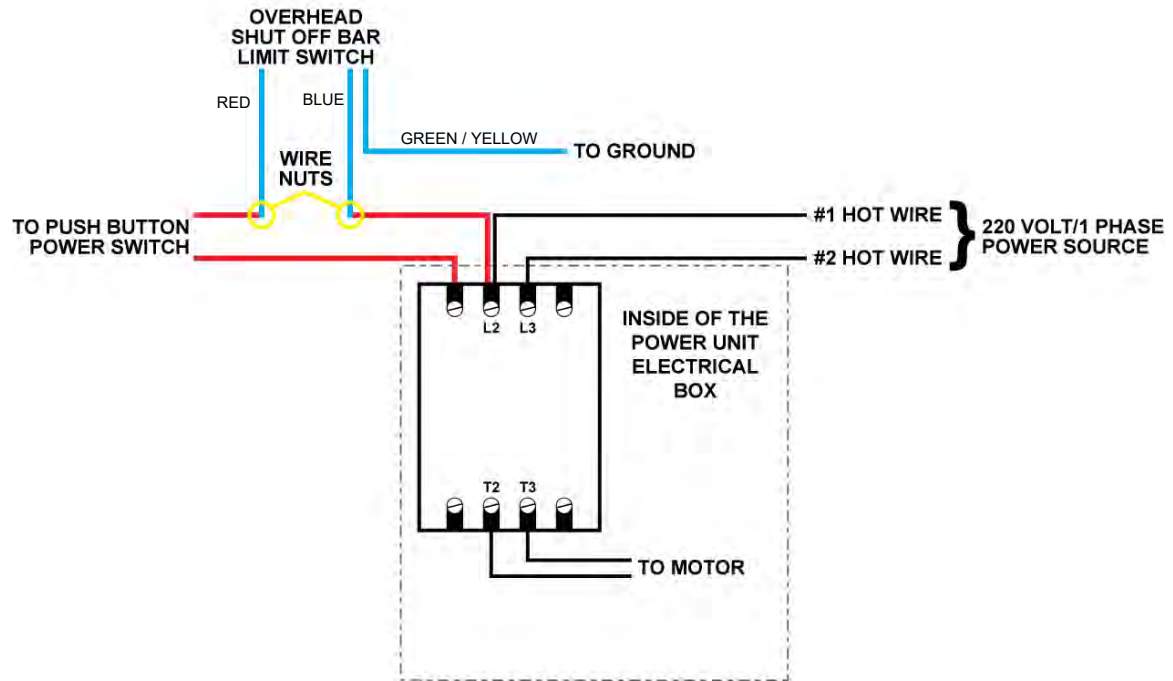

- STEP 5.** Now you can install the “Overhead Shut Off Bar Limit Switch.” First, cut either of the wires (it makes no difference which) connected to the “power” push button on the “faceplate” (see the picture below).

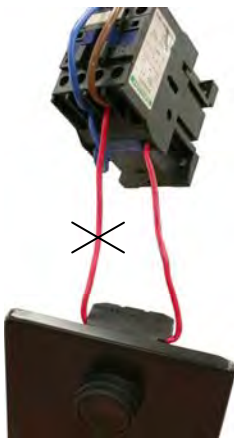

Cut either of the wires (it makes no difference which) connected to the “power” push button.

STEP 6. Remove the “eyelet” connectors from the end of the brown and blue wires coming from the limit switch. Connect one wire from the limit switch (brown or blue) to the part of the wire that you just cut that is coming from the push button. Then connect the other wire from the limit switch (brown or blue) to the other side of the wire that you just cut that is coming from the starter. Connect all wires using wire nuts.

Wires from the “Overhead Shut
Off Bar Limit Switch”

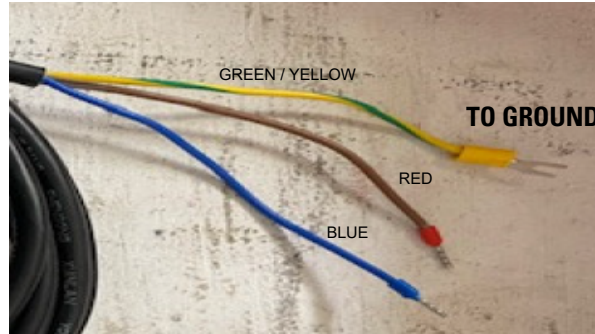

**WIRES TO CONNECT “IN-LINE”
WITH THE WIRE THAT WAS CUT
USING WIRE NUTS**

STEP 7. After the wire nuts are installed, it should look like the picture below:



STEP 8. The ground or yellow wire coming from the limit switch should be attached to the ground screw inside the power unit electrical box. (Same as ground wire in step 4 above). You can now reattach the faceplate and your lift is ready to use.

ATTENTION CUSTOMER: The overhead shutoff bar will have one end installed in the bracket that is attached to the “Overhead Shutoff Bar Limit Switch.” The other end of the overhead shutoff bar is attached directly to the overhead beam with a bolt (it has no bracket).